

May 6, 2022

Product Notification – DOC #1377742

Affected Parts: Y210-6005, Y210-1, Y210-2, Y210-9, Y210-CM056

Dear Valued Customer:

Nordson MEDICAL has made an improvement to the mold that produces the above parts to increase capacity in this time of high demand. The change involves updating the mold from a tab gate, which requires manually removing product from runners to a shear gate that will automatically degate the product from the runners. You may observe a new feature on the center grip section of the product, which is added specifically to allow for the shear gating feature.

This will be a running change as there is no change to product function, material or sealing surfaces, but you may observe product in the future that has this new feature as shown below.

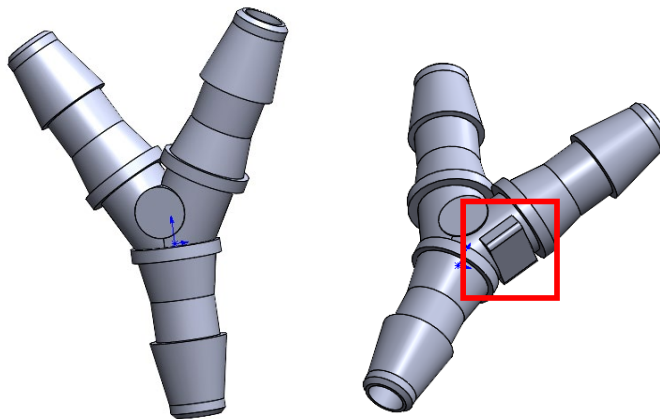

Image 1: Left – before adding shear gate. **Right** – after adding shear gate.

For answers to any questions you may have, please contact your sales account manager or our customer service team at orders@nordsonmedical.com. We appreciate your business and want to thank you for choosing Nordson MEDICAL.

Sincerely,



Jordan Berkel
Quality & Regulatory Manager
Nordson MEDICAL