

Product Change Notification

Product Change #: PCN377

Posting Date: April 18, 2018

Description of Change: FTLL410 Female threaded locking Luers are undergoing a change to the exterior geometry of the barbs to improve manufacturing efficiencies and enhance part quality. This change does not impact the flow path of the part but it will minimally impact the exterior barb geometry which interfaces with the tubing. New part samples will be available starting June 1st.

Before

After

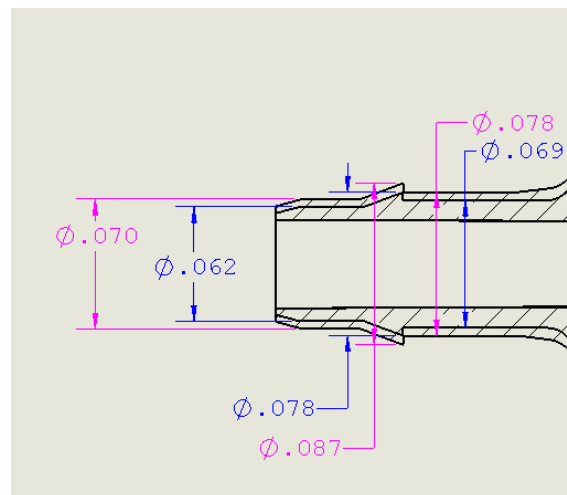

Reason: Improve manufacturing efficiencies and enhance part quality

Parts Affected: FTLL410-1, FTLL410-20, FTLL410-6005, FTLL410-9, FTLL410-9002, FTLL410-9010 and FTLL410-J1A

Effective Date: July 1st, 2018

Implementation Procedure:

Customers will have until May 1st to place production orders with Nordson MEDICAL for a last time purchase of the old revision to support their validation. Effective July 1st, Nordson MEDICAL will start transitioning to the new revision parts as the old inventory gets depleted. Updated engineering drawings will also be available on our website.