

REVISIONS						
SHEET	ZONE	REV.	ECO	DESCRIPTION	DATE	APPROVED
1	ALL	A	50311	UPDATE DWG TO CURRENT FORMAT & STANDARDS	1/17/2020	CKE

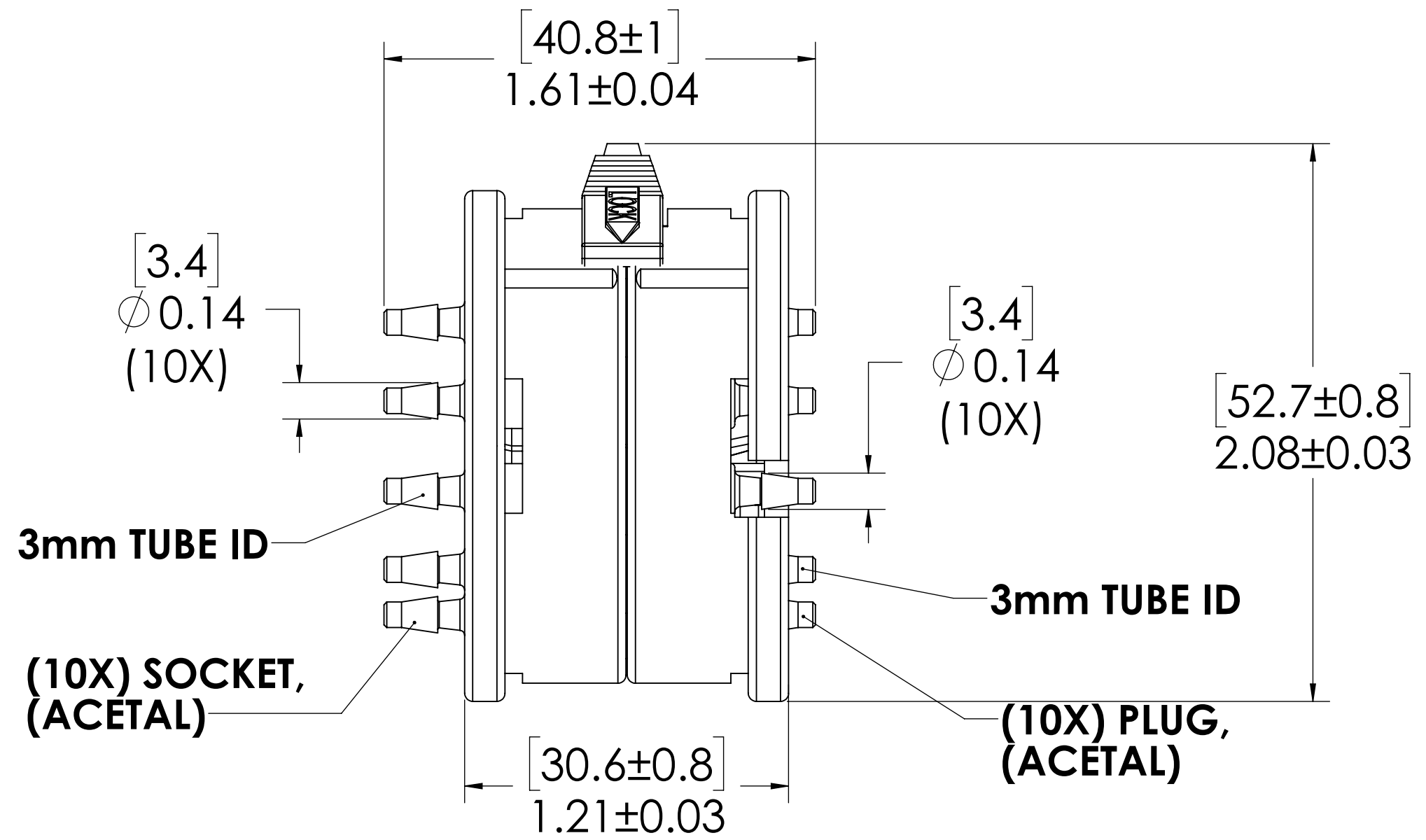
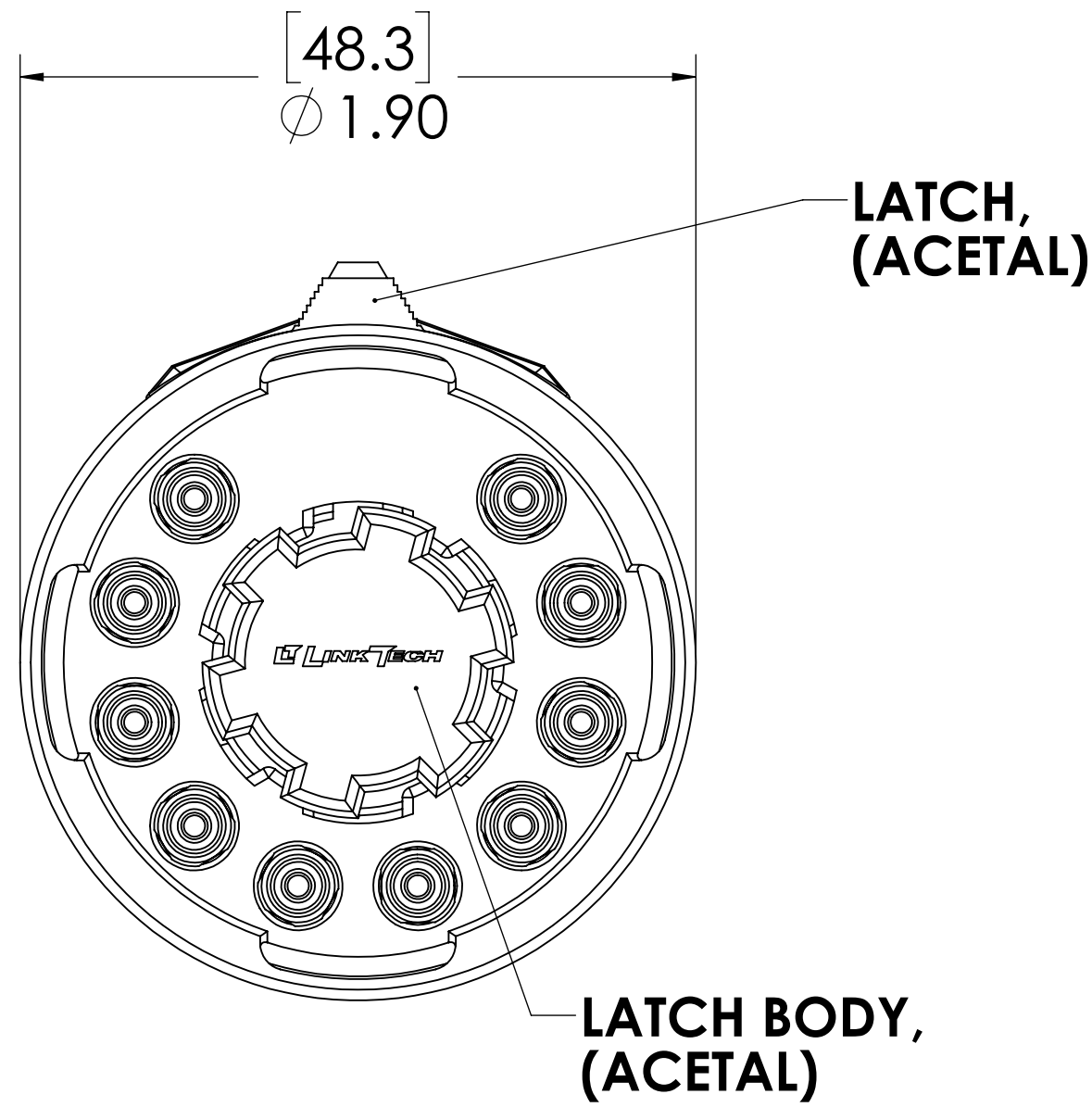
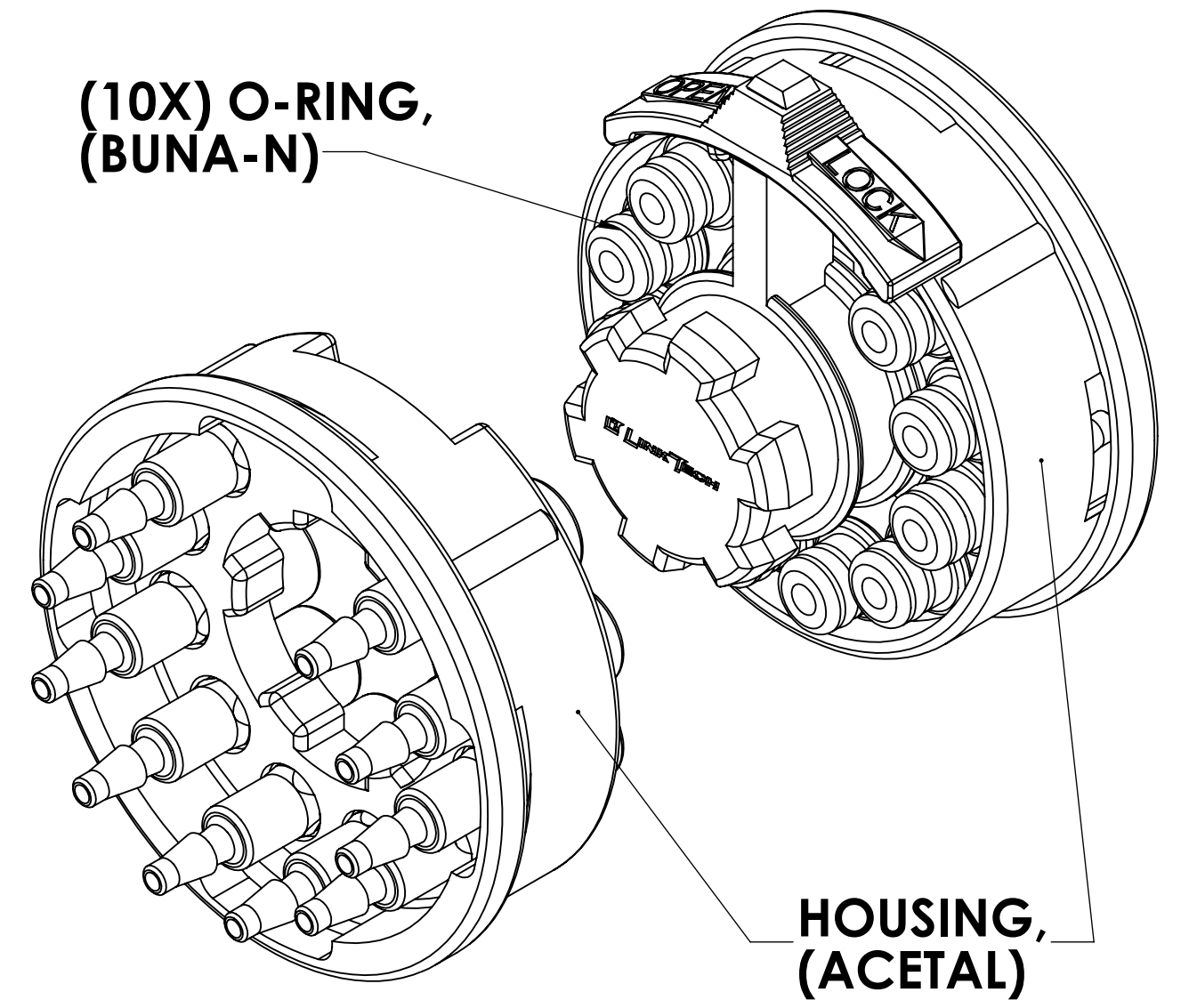

- NOTES:**
1. MATERIAL: ACETAL
 2. COLOR: BLACK
 3. O-RING MATERIAL: BUNA-N
 4. O-RINGS LUBRICATED WITH FOOD GRADE SILICONE OIL, 350 CST.

FOR REFERENCE ONLY

<small>UNLESS OTHERWISE SPECIFIED: DIMENSIONS ARE IN INCHES TOLERANCES: FRACTIONAL ± 1/32 ANGULAR: MACH ± 0.5 BEND ± 2 ONE PLACE DECIMAL ± 0.1 TWO PLACE DECIMAL ± 0.01 THREE PLACE DECIMAL ± 0.005 TWO PLACE DUAL (mm) [± 0.12]</small>	DRAWN	ER	11/02/17	
	CHECKED	CKE	1/6/20	
	ENG APPR.	HRC	1/17/20	
	MFG APPR.	BDB	1/17/20	
<small>PROPRIETARY AND CONFIDENTIAL</small>	Q.A.	LS	1/17/20	<small>THE INFORMATION CONTAINED IN THIS DRAWING IS THE SOLE PROPERTY OF LINKTECH LLC. ANY REPRODUCTION OR DISCLOSURE IN PART OR AS A WHOLE WITHOUT THE WRITTEN PERMISSION OF LINKTECH LLC IS STRICTLY PROHIBITED.</small>
<small>COMMENTS:</small>				PART NO: 100AC2-M3 DESCRIPTION: LinkTech 100AC Series Straight Coupling Non-valved, 3mm HB, Acetal SIZE DWG. NO. REV C 100AC100139 A SCALE: NTS WEIGHT: SHEET 1 OF 1