

REVISIONS						
SHEET	ZONE	REV.	ECO	DESCRIPTION	DATE	APPROVED
1	ALL	NC	50047	INITIAL RELEASE	6/11/2013	HRC
1	ALL	A	50253	UPDATE DWG TO CURRENT FORMAT & STANDARDS	5/15/2018	HRC

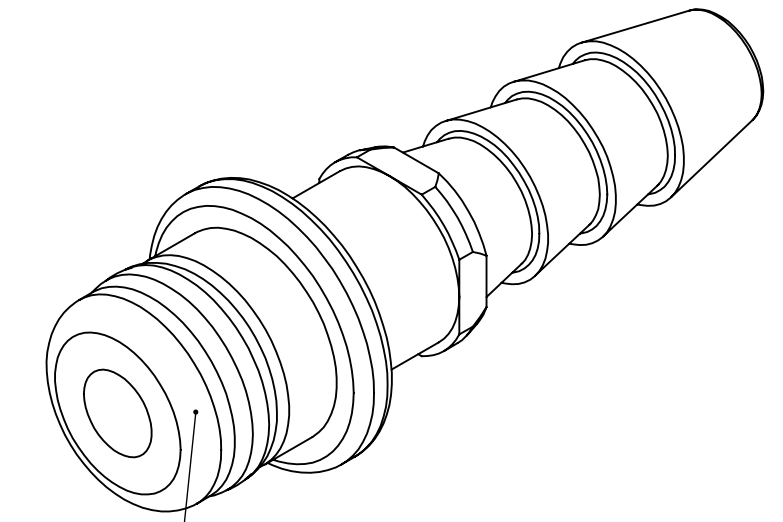

PLUG,  
(ACETAL)

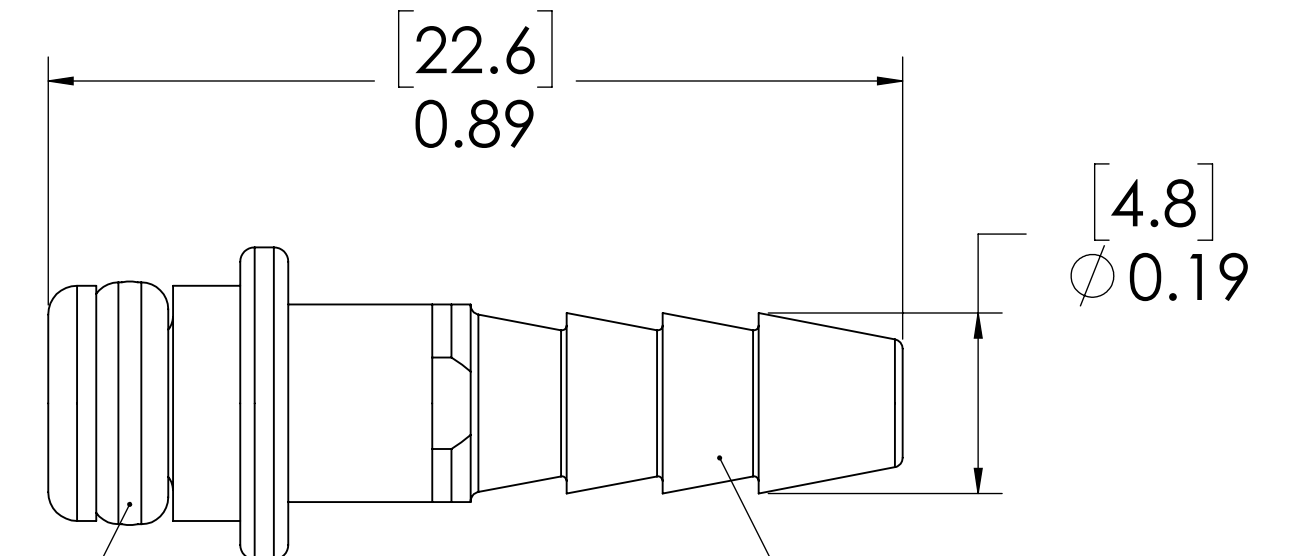
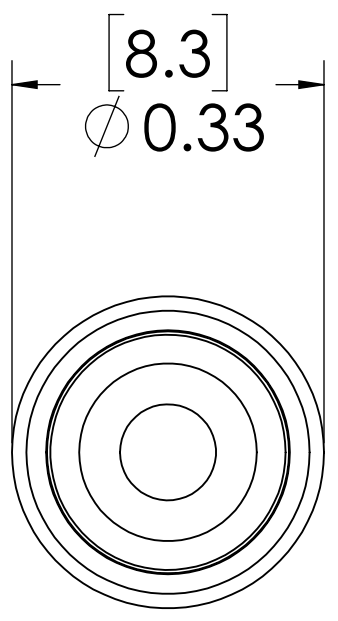

O-RING,  
(BUNA-N)

1/8" TUBE ID

**NOTES:**

1. MATERIAL: ACETAL
2. COLOR: NATURAL WHITE
3. O-RING MATERIAL: BUNA-N
4. O-RINGS LUBRICATED WITH FOOD GRADE SILICONE OIL, 350 CST.

**FOR REFERENCE ONLY**

<small>UNLESS OTHERWISE SPECIFIED:          DIMENSIONS ARE IN INCHES          TOLERANCES:          FRACTIONAL ± 1/32          ANGULAR: MACH ± 0.5 BEND ± 2          ONE PLACE DECIMAL ± 0.1          TWO PLACE DECIMAL ± 0.01          THREE PLACE DECIMAL ± 0.005          TWO PLACE DUAL (mm) [± 0.12]</small>	DRAWN	SCD	3/04/13	
	CHECKED	HRC	3/04/13	
	ENG APPR.	HRC	5/15/18	
	MFG APPR.	BDB	5/15/18	
<small>PROPRIETARY AND CONFIDENTIAL          THE INFORMATION CONTAINED IN THIS DRAWING IS THE SOLE PROPERTY OF LINKTECH LLC. ANY REPRODUCTION OR DISCLOSURE IN PART OR AS A WHOLE WITHOUT THE WRITTEN PERMISSION OF LINKTECH LLC IS STRICTLY PROHIBITED.</small>	PURCHASING	RK	5/15/18	PART NO: <b>10AC-PB2-02NS</b> DESCRIPTION: <b>LinkTech 10AC Series Straight Male, Non-valved, 1/8" HB, No Sleeve, Black, Natural Acetal</b>
SIZE DWG. NO. REV <b>C 10AC100048 A</b>		SCALE: NTS WEIGHT: SHEET 1 OF 1		