

REVISIONS						
SHEET	ZONE	REV.	ECO	DESCRIPTION	DATE	APPROVED
1	ALL	A	....	INITIAL RELEASE	7/11/2017	HRC
1	ALL	B	50253	UPDATE DWG TO CURRENT FORMAT & STANDARDS	5/15/2018	HRC

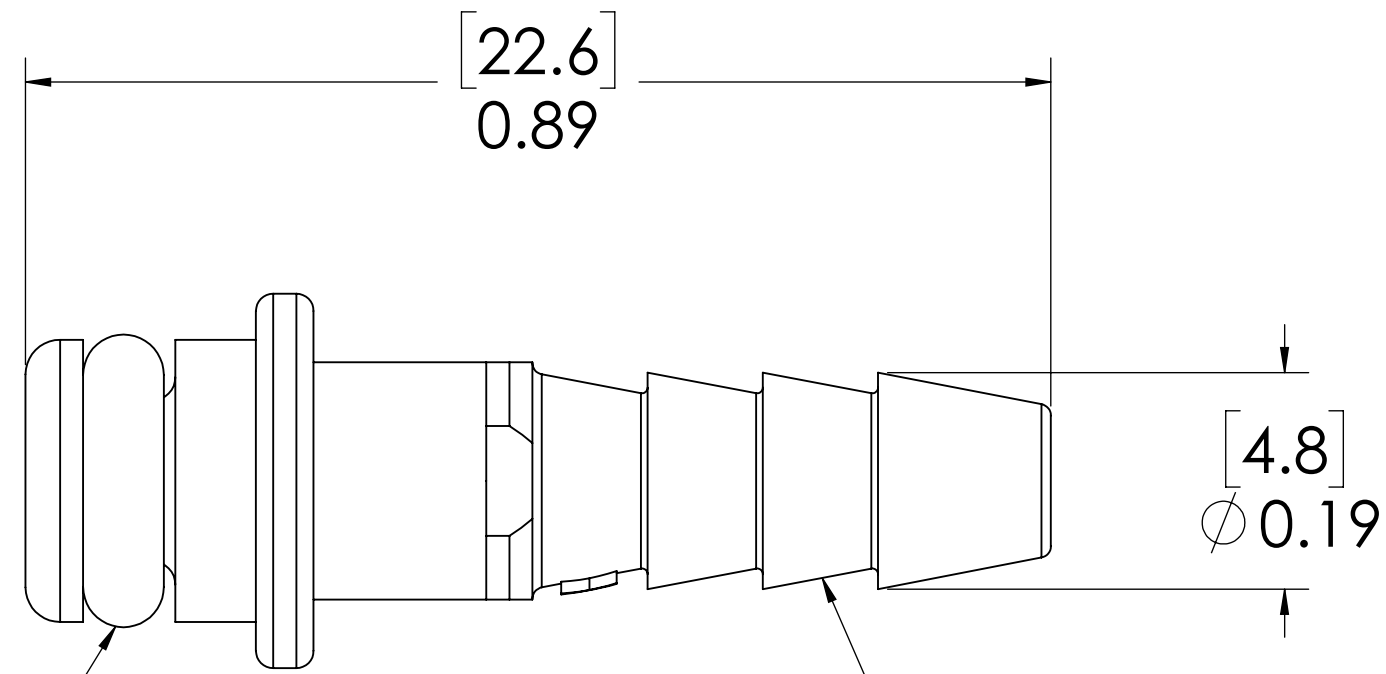
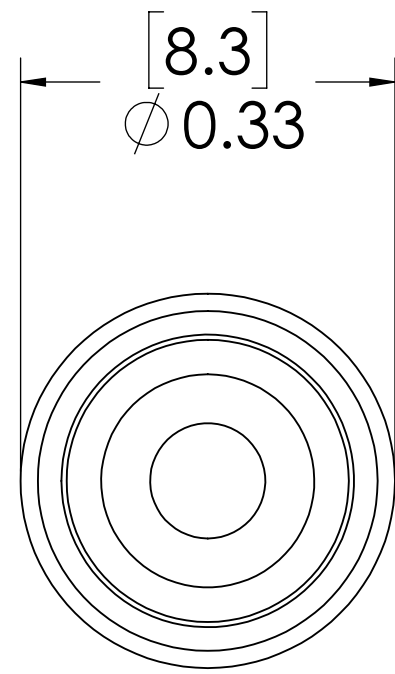
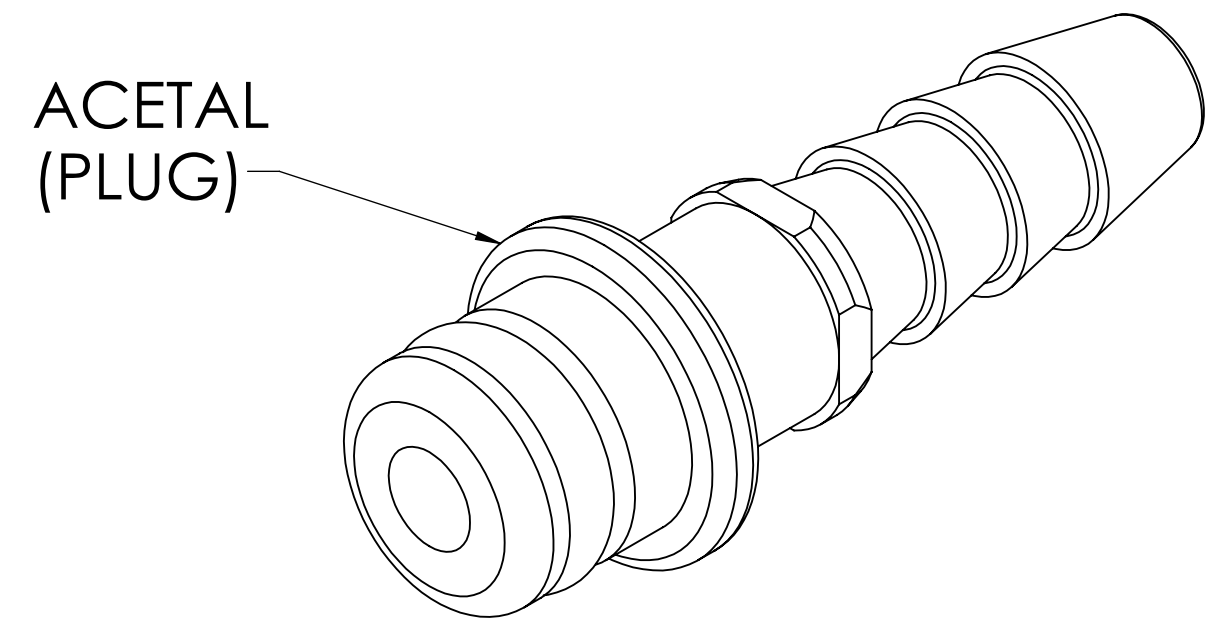

O-RING,  
(BUNA-N)

1/8" TUBE ID

**NOTES:**

1. MATERIAL: ACETAL
2. COLOR: BLACK
3. O-RING MATERIAL: BUNA-N
4. O-RINGS LUBRICATED WITH FOOD GRADE SILICONE OIL, 350 CST.

**FOR REFERENCE ONLY**

<small>UNLESS OTHERWISE SPECIFIED: DIMENSIONS ARE IN INCHES TOLERANCES: FRACTIONAL ± 1/32 ANGULAR, MACH ± 0.5 BEND ± 2 ONE PLACE DECIMAL ± 0.1 TWO PLACE DECIMAL ± 0.01 THREE PLACE DECIMAL ± 0.005 TWO PLACE DUAL (mm) [± 0.12]</small>	DRAWN	RDA	7/7/2017	
	CHECKED	HRC	7/7/2017	
	ENG APPR.	HRC	5/15/18	
	MFG APPR.	BDB	5/15/18	
<small>PROPRIETARY AND CONFIDENTIAL THE INFORMATION CONTAINED IN THIS DRAWING IS THE SOLE PROPERTY OF LINKTECH LLC. ANY REPRODUCTION OR DISCLOSURE IN PART OR AS A WHOLE WITHOUT THE WRITTEN PERMISSION OF LINKTECH LLC IS STRICTLY PROHIBITED.</small>	PURCHASING	RK	5/15/18	<b>PART NO:</b> <b>10AC-PB2-02NSBLK</b>
<small>COMMENTS:</small>				<b>DESCRIPTION:</b> <b>LinkTech 10AC Series Straight Male, Non-valved, 1/8" HB, No Sleeve, Black, Natural Acetal</b>
<b>SIZE</b>		<b>DWG. NO.</b>		<b>REV</b>
<b>C</b>		<b>10AC100074</b>		<b>B</b>
<b>SCALE:</b> NTS		<b>WEIGHT:</b>		<b>SHEET 1 OF 1</b>