

REVISIONS						
SHEET	ZONE	REV.	ECO	DESCRIPTION	DATE	APPROVED
ALL	ALL	A	50253	FORMAT UPDATE	3/29/2019	HRC

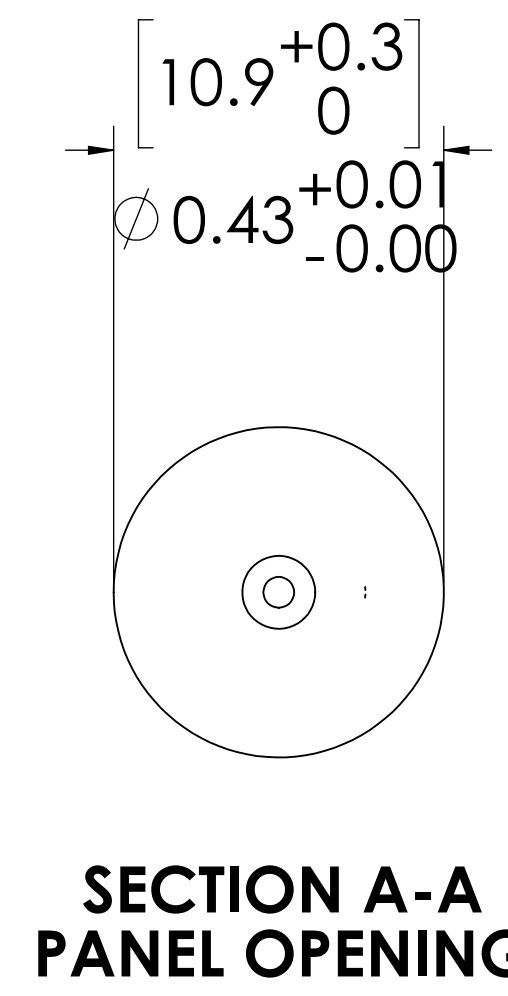
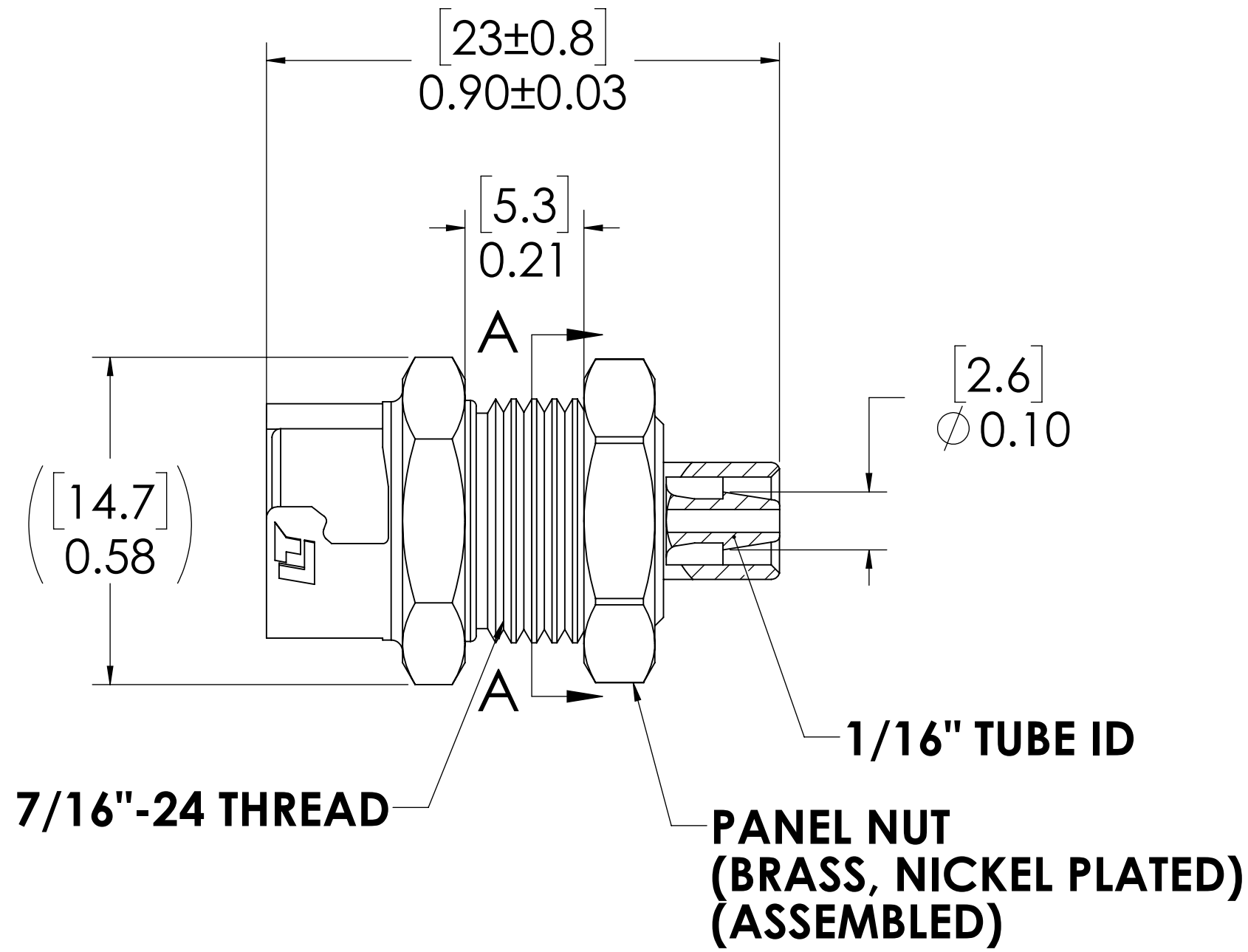
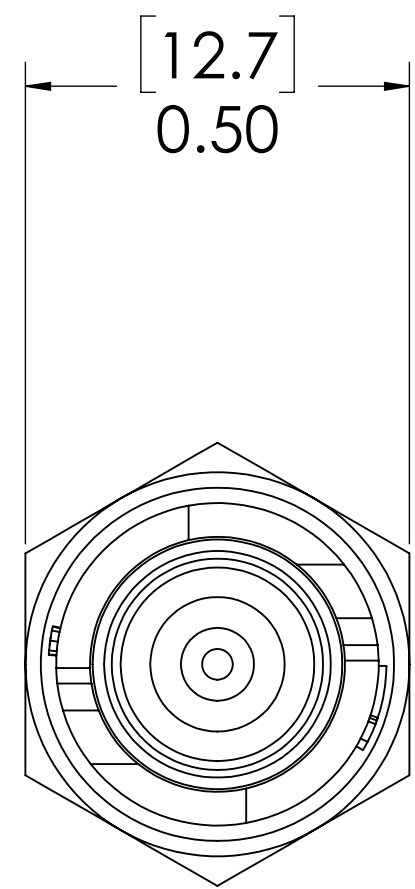
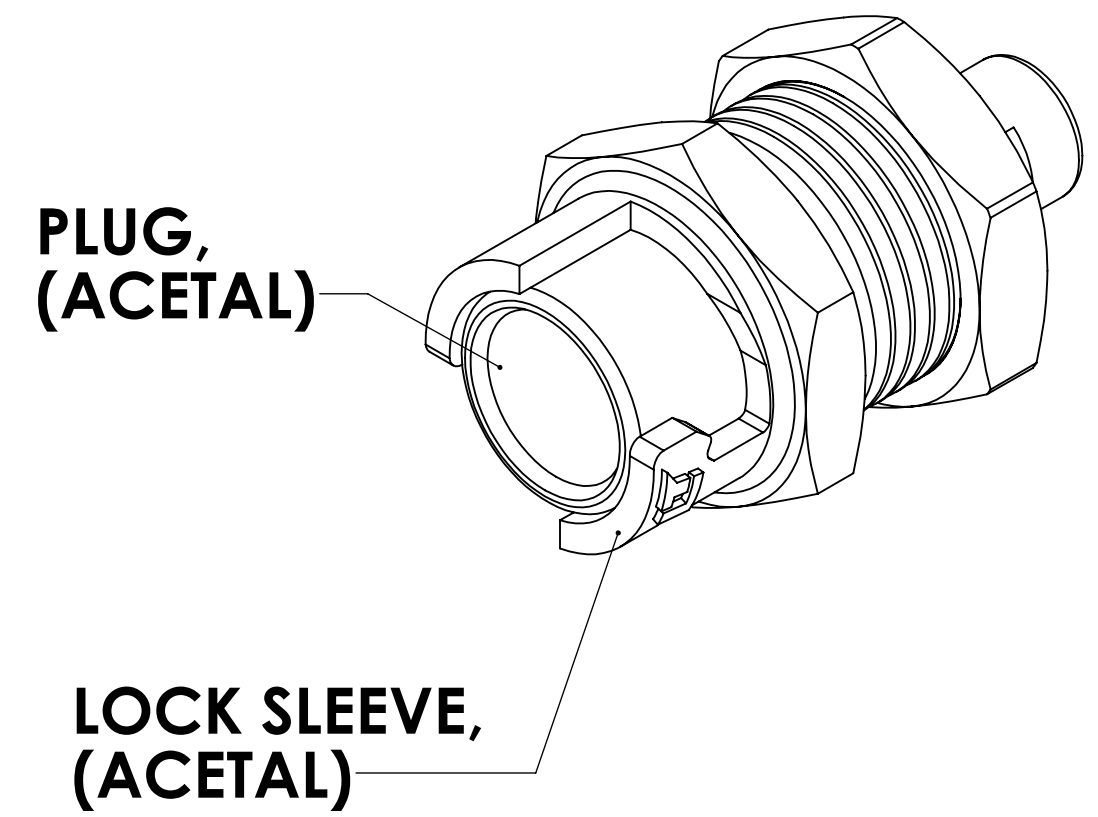

FOR REFERENCE ONLY

- NOTES:**
- MATERIAL: POLYPROPYLENE
 - COLOR: ALMOND, BARREL ACETAL.

<small>UNLESS OTHERWISE SPECIFIED: DIMENSIONS ARE IN INCHES TOLERANCES: FRACTIONAL ± 1/32 ANGULAR: MACH ± 0.5 BEND ± 2 ONE PLACE DECIMAL ± 0.1 TWO PLACE DECIMAL ± 0.01 THREE PLACE DECIMAL ± 0.005 TWO PLACE DUAL (mm) [± 0.12]</small>	DRAWN	RDA	3/19/2019	
	CHECKED	HRC	3/19/2019	
	ENG APPR.	HRC	3/29/19	
	MFG APPR.	BDB	3/29/19	
PRODUCTION	LS	3/29/19		PART NO: 10PP-S3-01 DESCRIPTION: LinkTech 10PP Series Panel Mt. Female, Non-valved, 116 HB, Polypropylene
<small>THE INFORMATION CONTAINED IN THIS DRAWING IS THE SOLE PROPERTY OF LINKTECH LLC. ANY REPRODUCTION OR DISCLOSURE IN PART OR AS A WHOLE WITHOUT THE WRITTEN PERMISSION OF LINKTECH LLC IS STRICTLY PROHIBITED.</small>	COMMENTS:			SIZE DWG. NO. REV C 10PP100022 A
				SCALE: NTS WEIGHT: SHEET 1 OF 1