

REVISIONS						
SHEET	ZONE	REV.	ECO	DESCRIPTION	DATE	APPROVED
1	ALL	A	50253	2017 FORMAT UPDATE	4/20/18	HRC

**PLUG BODY,
(ACETAL)**

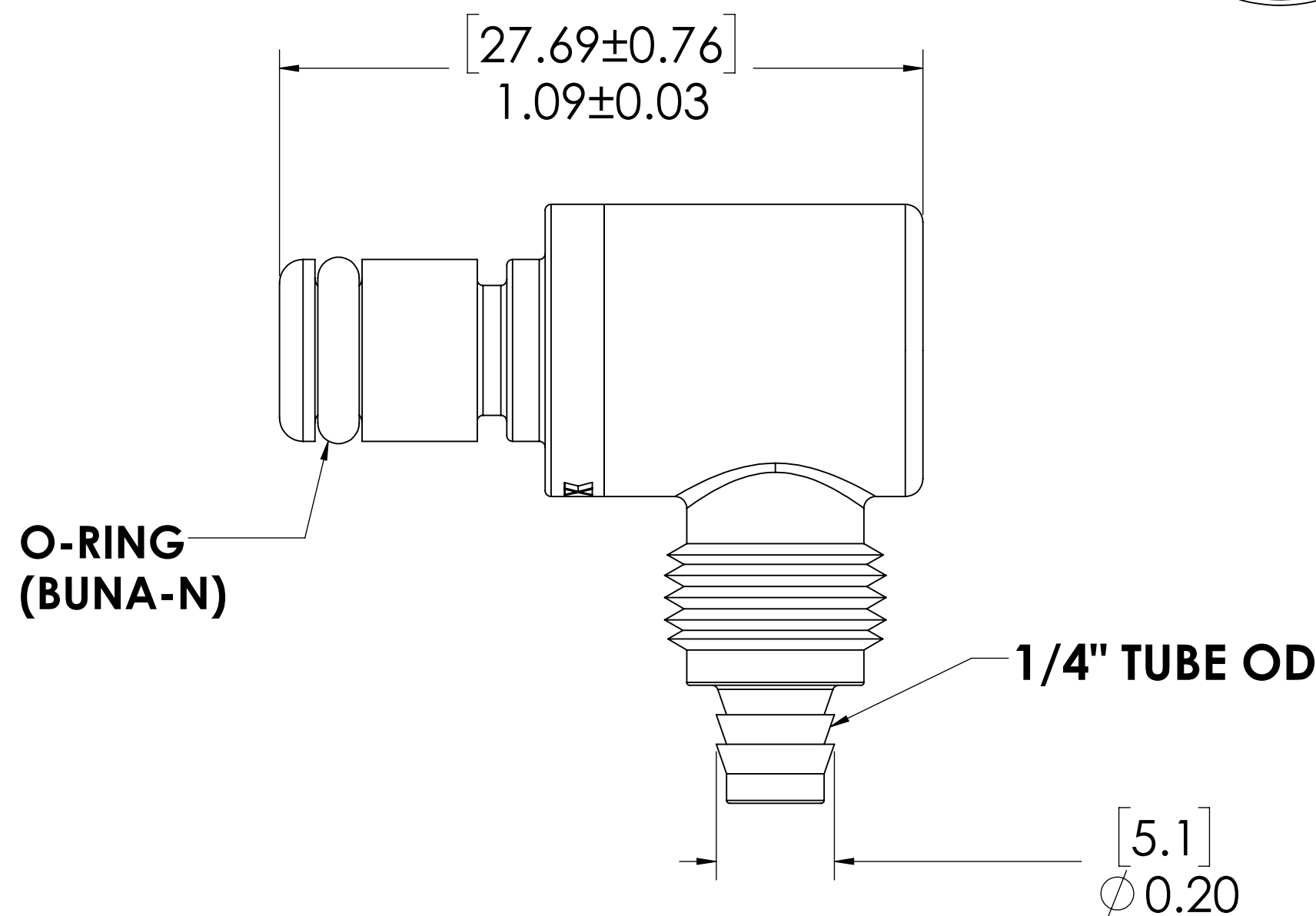
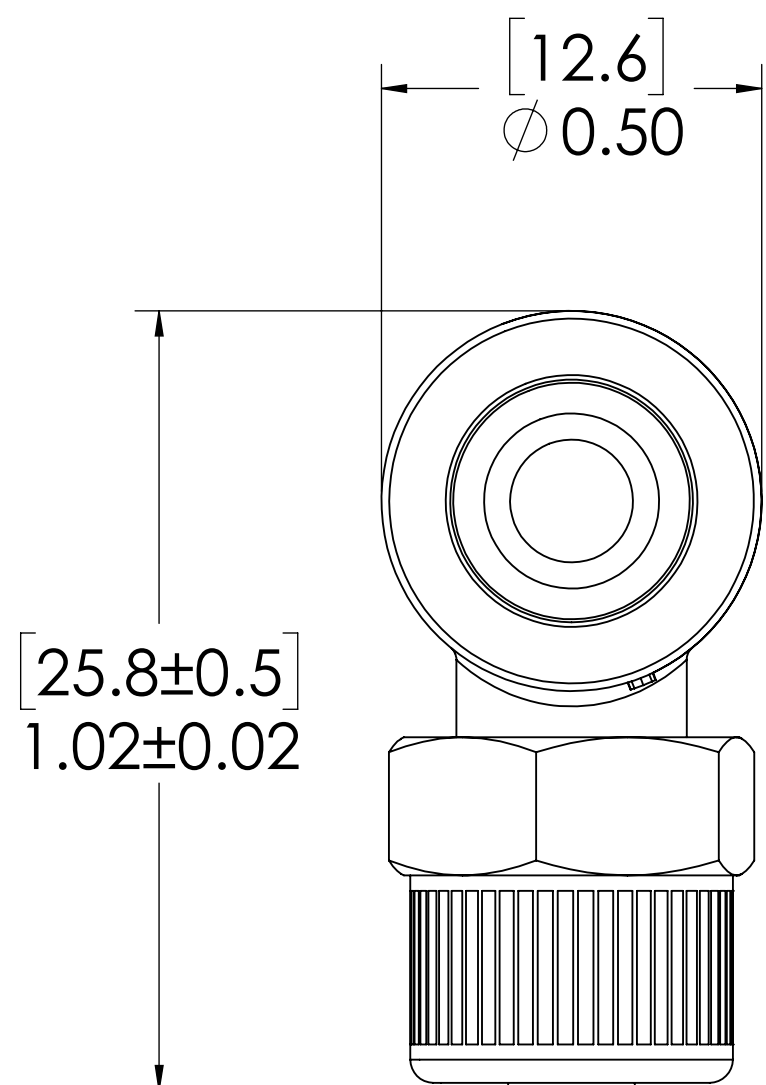
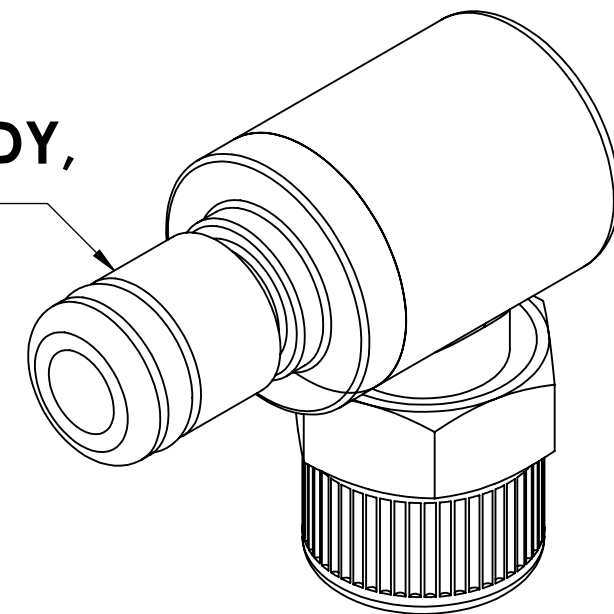

**O-RING
(BUNA-N)**

**PTF NUT,
(BRASS, NICKEL PLATED)
PACKAGED SEPARATELY**

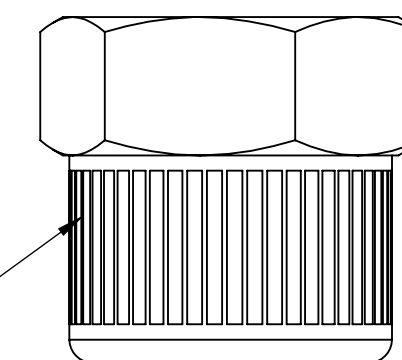

NOTES:

- MATERIAL: ACETAL
- COLOR: NATURAL WHITE
- O-RING MATERIAL: BUNA-N
- O-RINGS LUBRICATED WITH FOOD GRADE SILICONE OIL, 350CST

FOR REFERENCE ONLY

<small>UNLESS OTHERWISE SPECIFIED: DIMENSIONS ARE IN INCHES TOLERANCES: FRACTIONAL ± 1/32 ANGULAR: MACH ± 0.5 BEND ± 2 ONE PLACE DECIMAL ± 0.1 TWO PLACE DECIMAL ± 0.01 THREE PLACE DECIMAL ± 0.005 TWO PLACE DUAL (mm) [± 0.12]</small>	DRAWN	RDA	4/12/2018	
	CHECKED	HRC	4/12/18	
	ENG APPR.	HRC	4/20/18	
	MFG APPR.	BDB	4/20/18	
<small>PROPRIETARY AND CONFIDENTIAL THE INFORMATION CONTAINED IN THIS DRAWING IS THE SOLE PROPERTY OF LINKTECH LLC. ANY REPRODUCTION OR DISCLOSURE IN PART OR AS A WHOLE WITHOUT THE WRITTEN PERMISSION OF LINKTECH LLC IS STRICTLY PROHIBITED.</small>	PURCHASING	RK	4/20/18	PART NO: 20AC-PB10-04 DESCRIPTION: LinkTech 20AC Series Elbow Male, NV, 250 PTF, Natural Acetal SIZE DWG. NO. REV C 20AC200390 A
SCALE: NTS			WEIGHT:	SHEET 1 OF 1