

REVISIONS						
SHEET	ZONE	REV.	ECO	DESCRIPTION	DATE	APPROVED
1	ALL	A	50253	UPDATE DWG TO CURRENT FORMAT & STANDARDS	6/28/2015	HRC

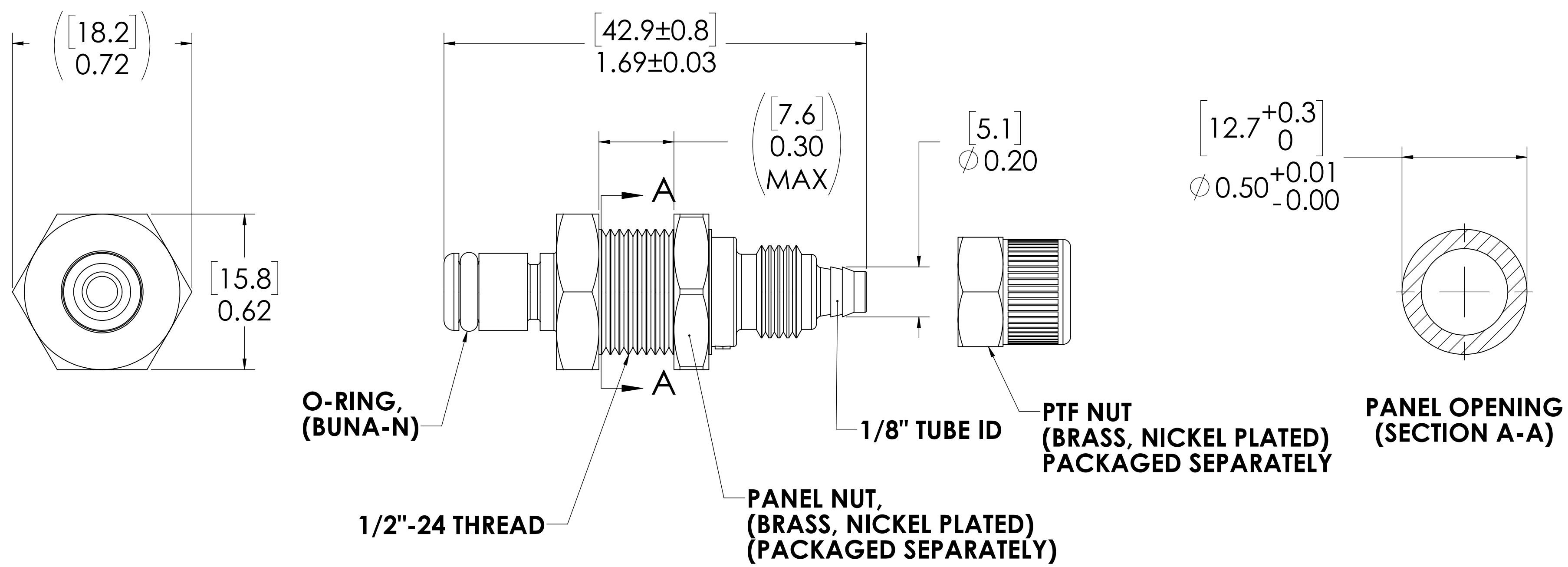
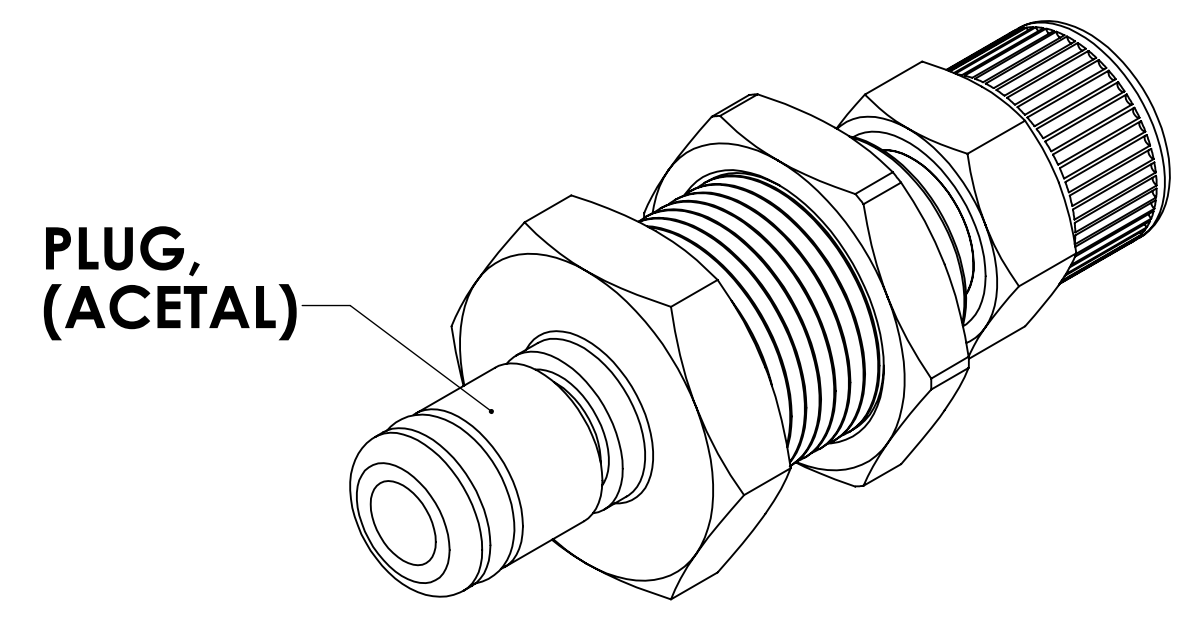

- NOTES:**
- MATERIAL: ACETAL
 - COLOR: NATURAL WHITE
 - O-RING MATERIAL: BUNA-N
 - O-RINGS LUBRICATED WITH FOOD GRADE SILICONE OIL, 350 CST.

FOR REFERENCE ONLY

<small>UNLESS OTHERWISE SPECIFIED: DIMENSIONS ARE IN INCHES TOLERANCES: FRACTIONAL ± 1/32 ANGULAR, MACH ± 0.5 BEND ± 2 ONE PLACE DECIMAL ± 0.1 TWO PLACE DECIMAL ± 0.01 THREE PLACE DECIMAL ± 0.005 TWO PLACE DUAL (mm) [± 0.12]</small>	DRAWN	ER	09-28-17	
	CHECKED	HRC	09-28-17	
	ENG APPR.	HRC	06-28-18	
	MFG APPR.	BDB	06-28-18	
PRODUCTION	LS	06-28-18		PART NO: 20AC-PB8-04 DESCRIPTION: LinkTech 20AC Series Panel Mt. Male, Non-valved, 1/4" PTF, Natural Acetal
<small>PROPRIETARY AND CONFIDENTIAL THE INFORMATION CONTAINED IN THIS DRAWING IS THE SOLE PROPERTY OF LINKTECH LLC. ANY REPRODUCTION OR DISCLOSURE IN PART OR AS A WHOLE WITHOUT THE WRITTEN PERMISSION OF LINKTECH LLC IS STRICTLY PROHIBITED.</small>	COMMENTS:			SIZE DWG. NO. REV C 20AC200354 A
	SCALE: NTS	WEIGHT:		SHEET 1 OF 1