

REVISIONS						
SHEET	ZONE	REV.	ECO	DESCRIPTION	DATE	APPROVED
1	ALL	A	50242	UPDATE DWG TO CURRENT FORMAT & STANDARDS	10/12/2018	HRC

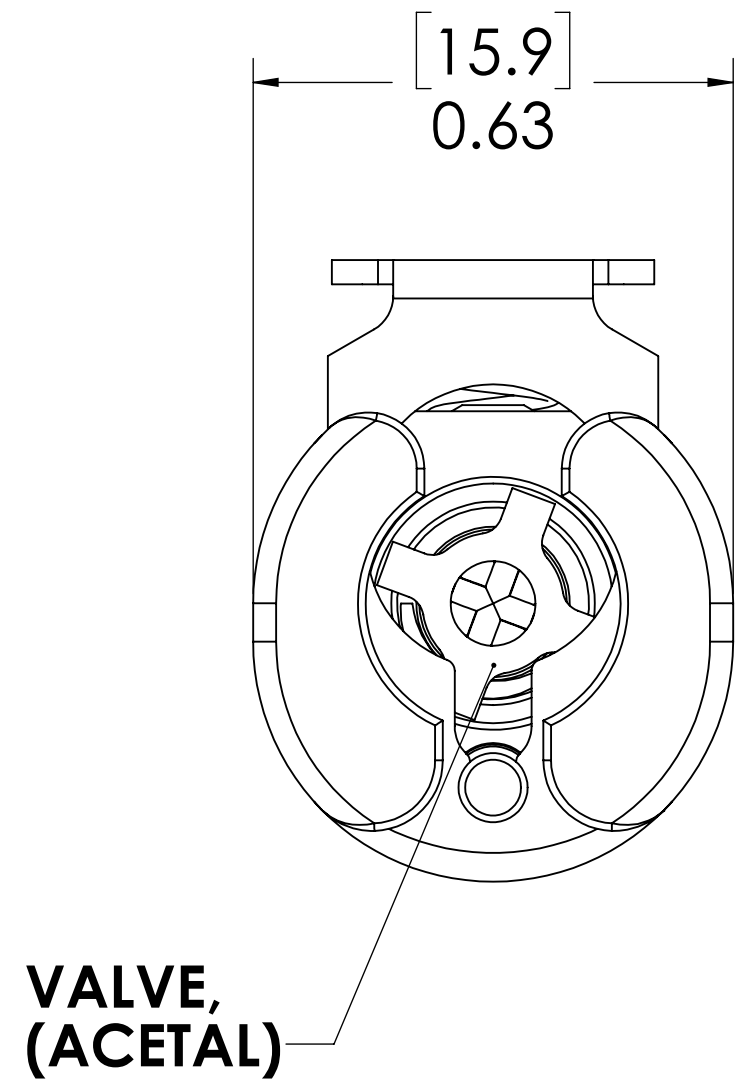

**LATCH HARDWARE,
(STAINLESS STEEL)**

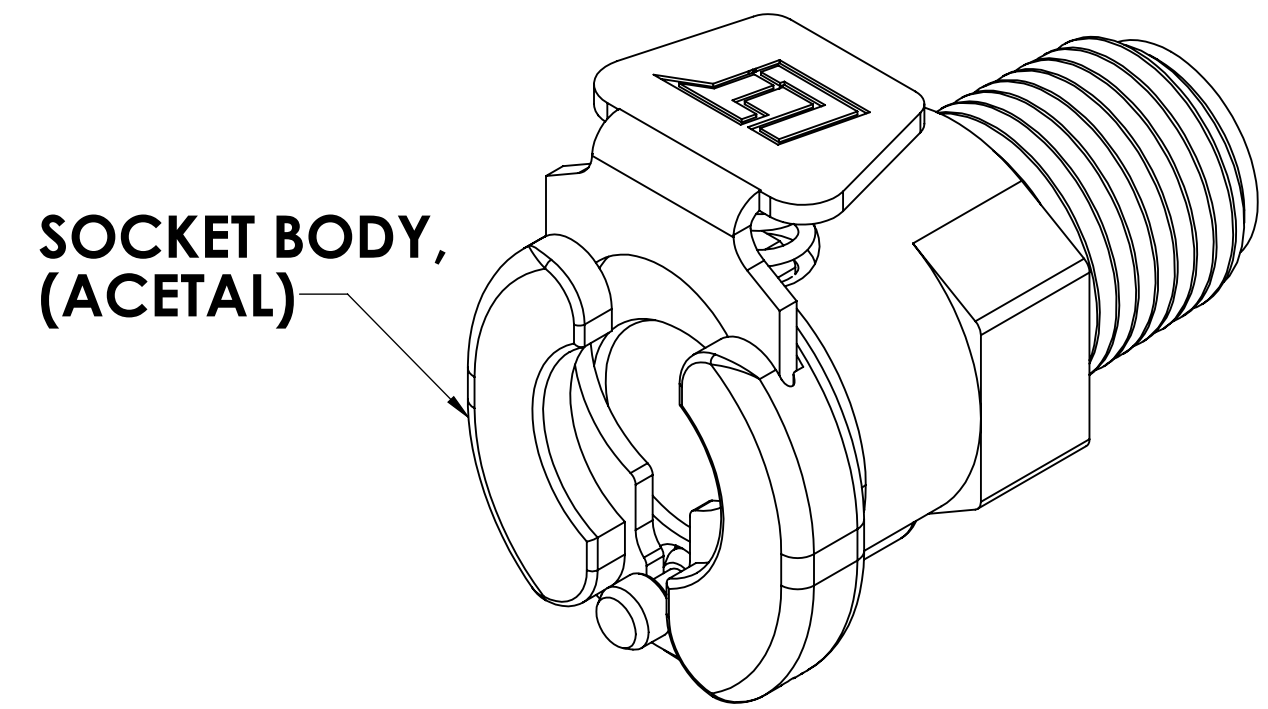
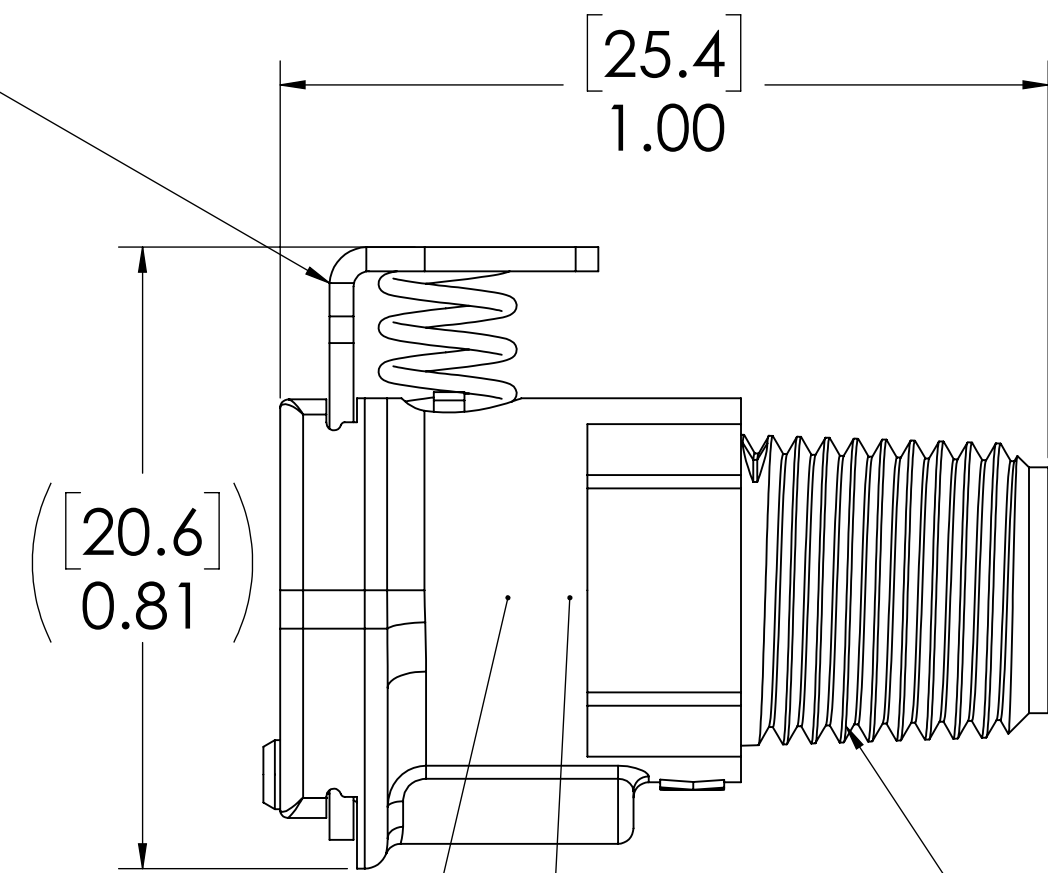

**VALVE SPRING,
INTERNAL
(STAINLESS STEEL)**

**VALVE O-RING,
INTERNAL
(BUNA-N)**

**1/8" BSPT
(PIPE THREAD)**

NOTES:

1. MATERIAL: ACETAL
2. COLOR: NATURAL WHITE
3. O-RING MATERIAL: BUNA-N
4. O-RINGS LUBRICATED WITH FOOD GRADE SILICONE OIL, 350 CST.

FOR REFERENCE ONLY

<small>UNLESS OTHERWISE SPECIFIED: DIMENSIONS ARE IN INCHES TOLERANCES: FRACTIONAL ± 1/32 ANGULAR: MACH ± 0.5 BEND ± 2 ONE PLACE DECIMAL ± 0.1 TWO PLACE DECIMAL ± 0.01 THREE PLACE DECIMAL ± 0.005 TWO PLACE DUAL (mm) [± 0.12]</small>	DRAWN	ER	09-22-17	
	CHECKED	HRC	09-22-17	
	ENG APPR.	HRC	10/12/18	
	MFG APPR.	BDB	10/12/18	
PRODUCTION	LS	10/12/18		PART NO: 20ACV-SB1-02BSPT DESCRIPTION: LinkTech 20AC Series Male Thread Female, Valved, 1/8" BSPT, Natural Acetal
<small>PROPRIETARY AND CONFIDENTIAL THE INFORMATION CONTAINED IN THIS DRAWING IS THE SOLE PROPERTY OF LINKTECH LLC. ANY REPRODUCTION OR DISCLOSURE IN PART OR AS A WHOLE WITHOUT THE WRITTEN PERMISSION OF LINKTECH LLC IS STRICTLY PROHIBITED.</small>	COMMENTS:			SIZE DWG. NO. REV C 20AC200335 A
SCALE: NTS		WEIGHT:	SHEET 1 OF 1	