

REVISIONS						
SHEET	ZONE	REV.	ECO	DESCRIPTION	DATE	APPROVED
1	E3	A	50162	ADD GASKET SEAL TO ASSEMBLY/UPDATE SHEET FORMAT	8/7/2015	HRC
1	ALL	B	50242	UPDATE DWG TO CURRENT FORMAT & STANDARDS	10/12/2018	HRC

**LATCH HARDWARE,
(STAINLESS STEEL)**

**GASKET,
(BUNA-N)**

**SOCKET,
(ACETAL)**

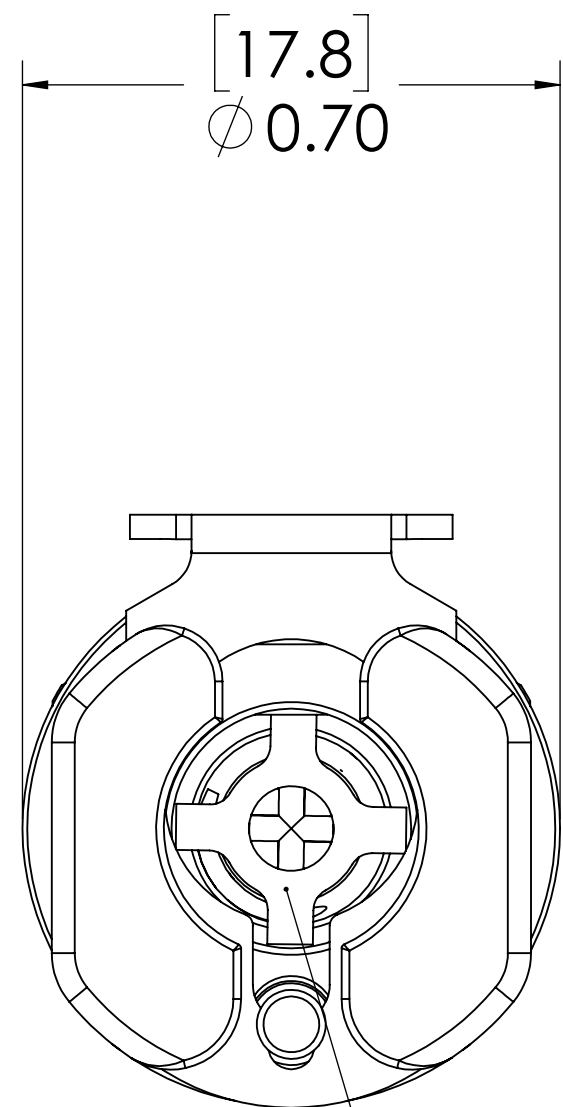
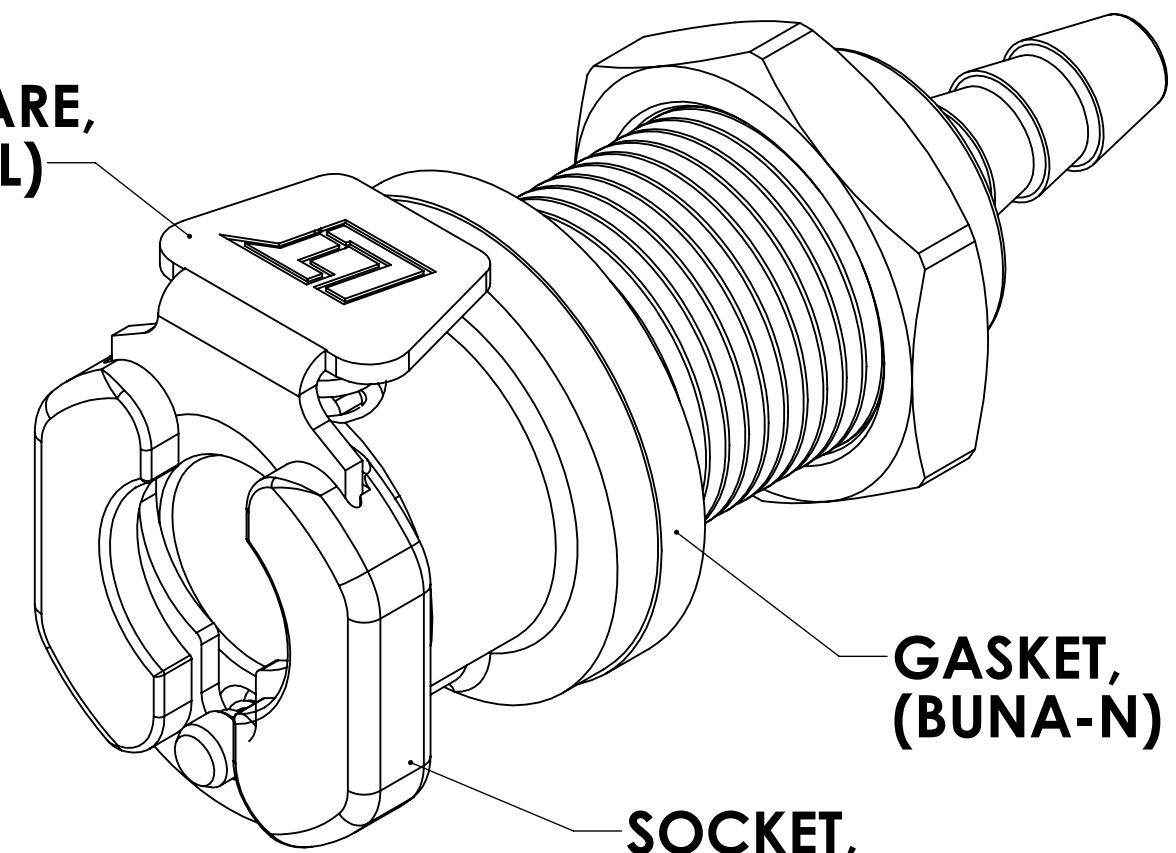

**VALVE,
(ACETAL)**

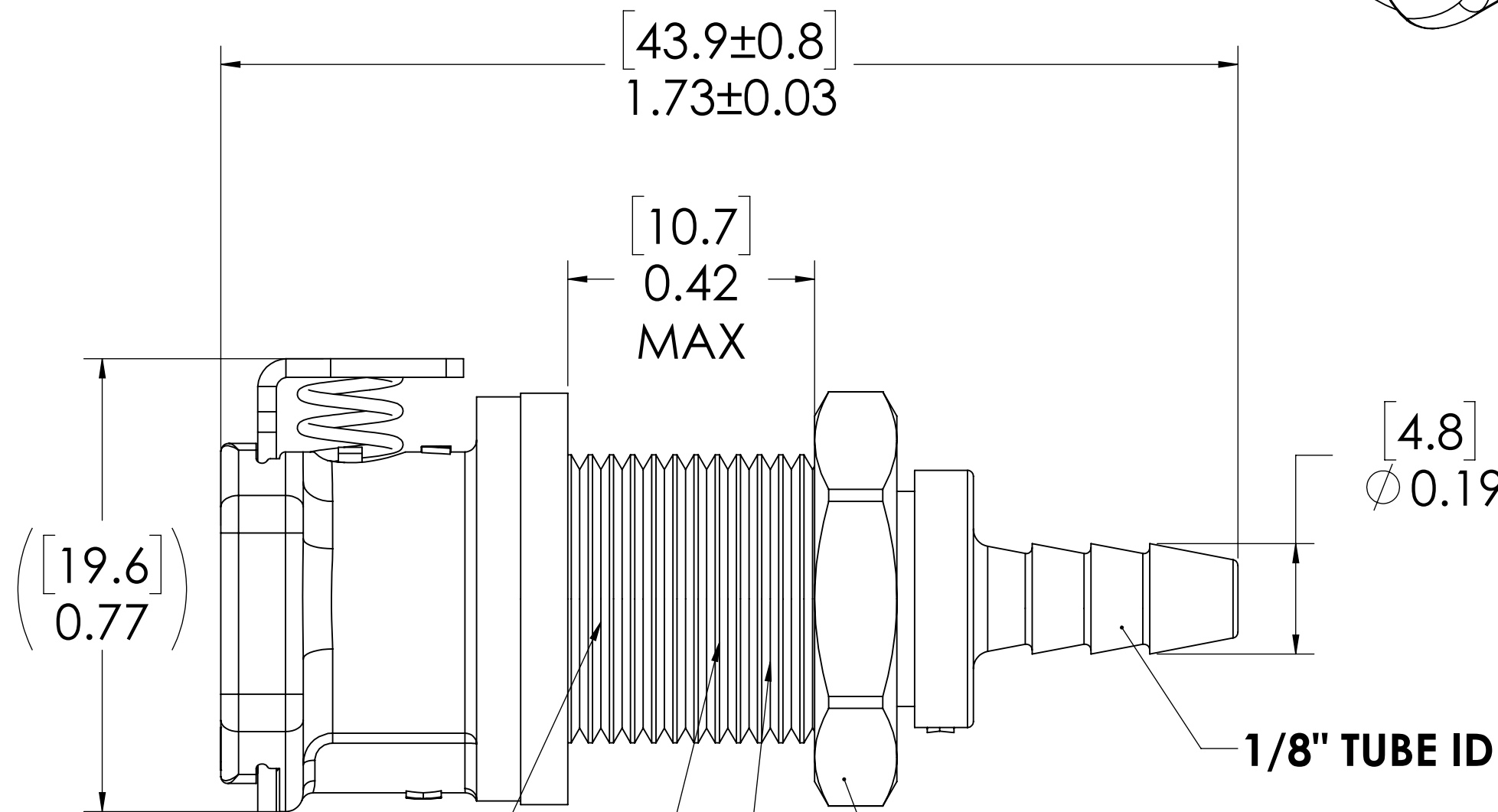

**VALVE O-RING,
INTERNAL
(BUNA-N)**

**VALVE SPRING,
INTERNAL
(STAINLESS STEEL)**

**PANEL NUT,
(BRASS, NICKEL PLATED)
(PACKAGED SEPARATELY)**

1/8" TUBE ID

1/2"-24 THREAD

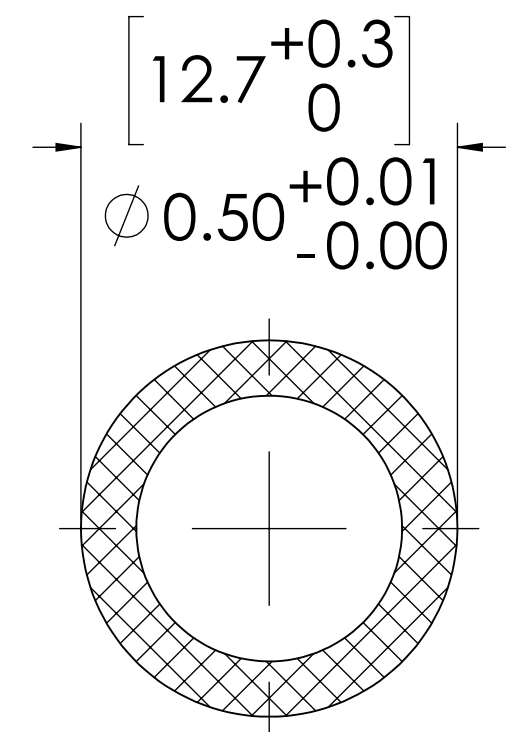

PANEL OPENING

NOTES:

- MATERIAL: ACETAL
- COLOR: NATURAL ACETAL
- O-RING MATERIAL: BUNA-N
- O-RINGS LUBRICATED WITH FOOD GRADE SILICONE OIL, 350 CST.

FOR REFERENCE ONLY

<small>UNLESS OTHERWISE SPECIFIED: DIMENSIONS ARE IN INCHES TOLERANCES: FRACTIONAL ±1/32 ANGULAR: MACH ±0.5 BEND ±2 ONE PLACE DECIMAL ±0.1 TWO PLACE DECIMAL ±0.01 THREE PLACE DECIMAL ±0.005 TWO PLACE DUAL (mm) [±0.12]</small>	DRAWN	ER	09-25-17	
	CHECKED	HRC	09-25-17	
	ENG APPR.	HRC	10/12/18	
	MFG APPR.	BDB	10/12/18	
PRODUCTION	LS	10/12/18		PART NO: 20ACV-SB3-02GS DESCRIPTION: LinkTech 20AC Series Panel Mt. Gasket Seal Female, Valved, 1/8" HB, Natural Acetal
<small>THE INFORMATION CONTAINED IN THIS DRAWING IS THE SOLE PROPERTY OF LINKTECH LLC. ANY REPRODUCTION OR DISCLOSURE IN PART OR AS A WHOLE WITHOUT THE WRITTEN PERMISSION OF LINKTECH LLC IS STRICTLY PROHIBITED.</small>				SIZE DWG. NO. REV C 20AC200136 B
SCALE: NTS			WEIGHT:	SHEET 1 OF 1