

| REVISIONS |      |      |       |                    |            |          |
|-----------|------|------|-------|--------------------|------------|----------|
| SHEET     | ZONE | REV. | ECO   | DESCRIPTION        | DATE       | APPROVED |
| 1         | ALL  | A    | 50253 | 2017 FORMAT UPDATE | 10/18/2018 | HRC      |

**PLUG,  
(BRASS, NICKEL  
AND CHROME PLATED)**

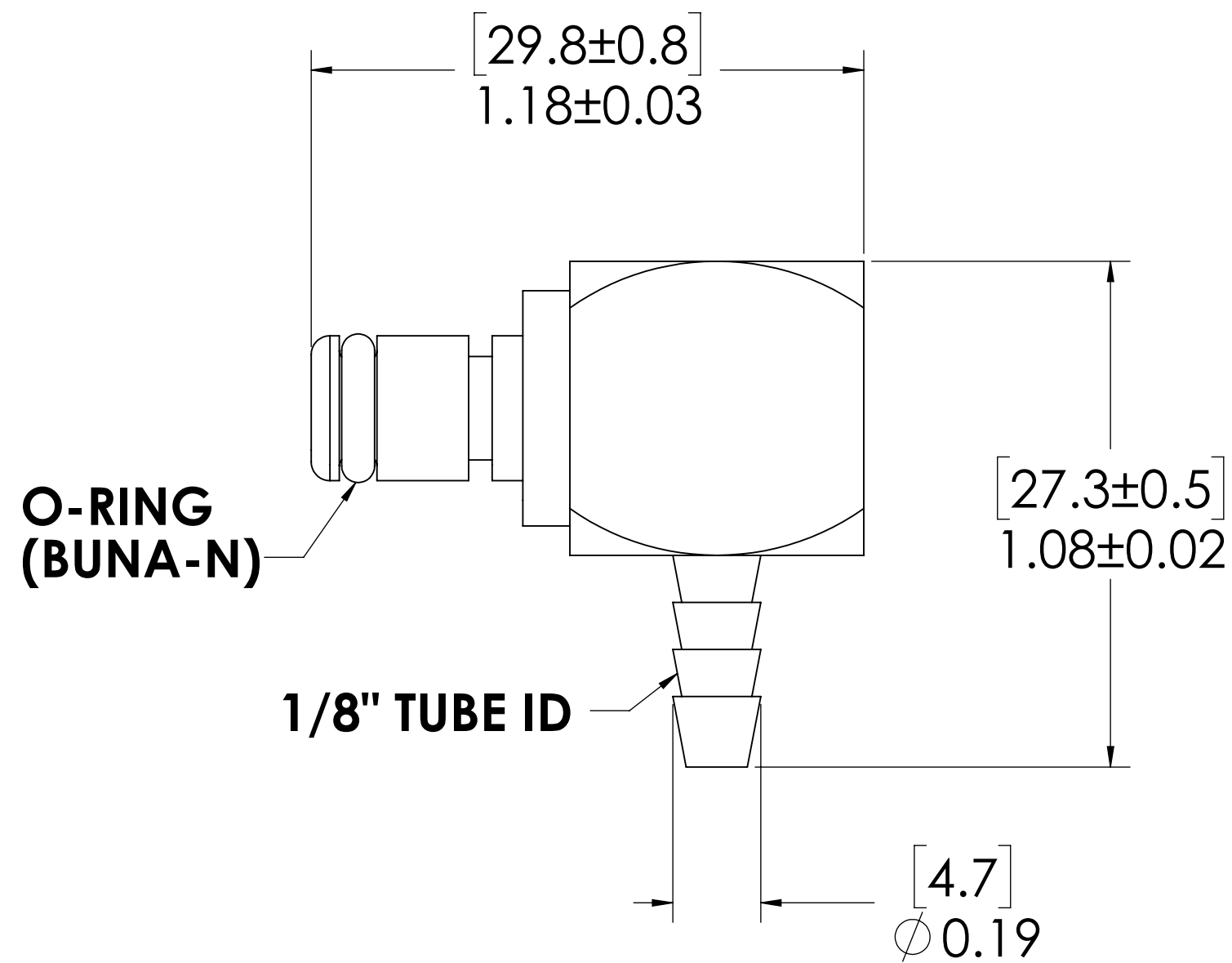
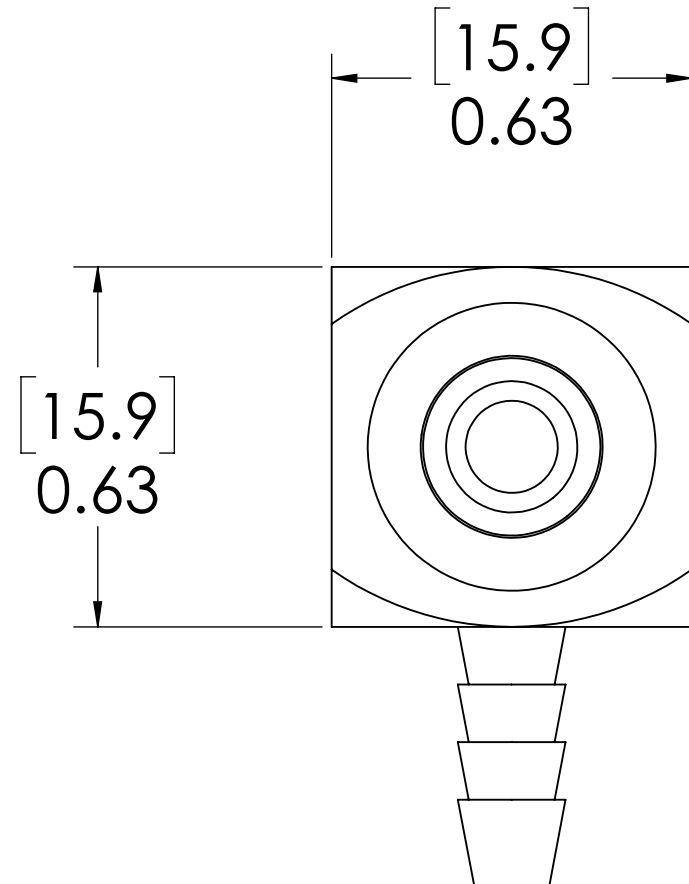
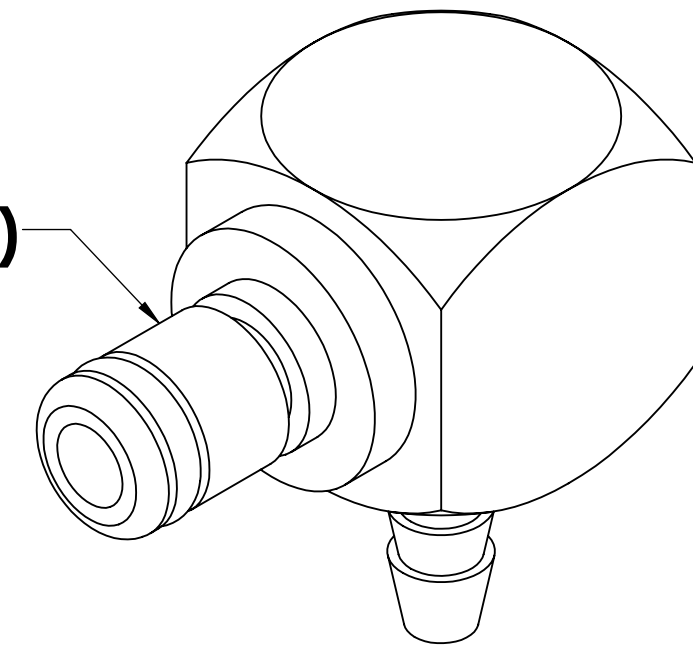

**NOTES:**

1. MATERIAL: BRASS
2. COLOR: CHROME
3. O-RING MATERIAL: BUNA-N
4. O-RINGS LUBRICATED WITH FOOD GRADE SILICONE OIL, 350 CST.

**FOR REFERENCE ONLY**

|  |            |     |           |   |
|--|------------|-----|-----------|---|
| UNLESS OTHERWISE SPECIFIED:<br>DIMENSIONS ARE IN INCHES<br>TOLERANCES:<br>FRACTIONAL ± 1/32<br>ANGULAR: MACH ± 0.5 BEND ± 2<br>ONE PLACE DECIMAL ± 0.1<br>TWO PLACE DECIMAL ± 0.01<br>THREE PLACE DECIMAL ± 0.005<br>TWO PLACE DECIMAL (mm) [± 0.12]   | DRAWN      | RDA | 1/17/2018 | <br><b>PART NO: 20CB-PB4-02</b><br><b>DESCRIPTION:</b><br><b>20CB-PB4-02 LinkTech 20CB Series Elbow Male, Non-valved, 125 HB, Chrome Brass</b> |
|  | CHECKED    | HRC | 1/17/2018 |   |
| <b>PROPRIETARY AND CONFIDENTIAL</b><br><br>THE INFORMATION CONTAINED IN THIS DRAWING IS THE SOLE PROPERTY OF LINKTECH LLC. ANY REPRODUCTION OR DISCLOSURE IN PART OR AS A WHOLE WITHOUT THE WRITTEN PERMISSION OF LINKTECH LLC IS STRICTLY PROHIBITED. | ENG APPR.  | HRC | 10/18/18  | <b>SIZE DWG. NO.</b><br><b>C 20CB200171</b>   |
|  | MFG APPR.  | BDB | 10/18/18  | <b>REV</b><br><b>A</b>  |
|  | PRODUCTION | LS  | 10/18/18  | <b>SCALE: NTS</b>   <b>WEIGHT:</b>   <b>SHEET 1 OF 1</b>  |