

REVISIONS						
SHEET	ZONE	REV.	ECO	DESCRIPTION	DATE	APPROVED
1	ALL	A	50281	CONICAL SPRING UPDATE	9/21/2018	HRC

**PLUG,
(POLYPROPYLENE)**

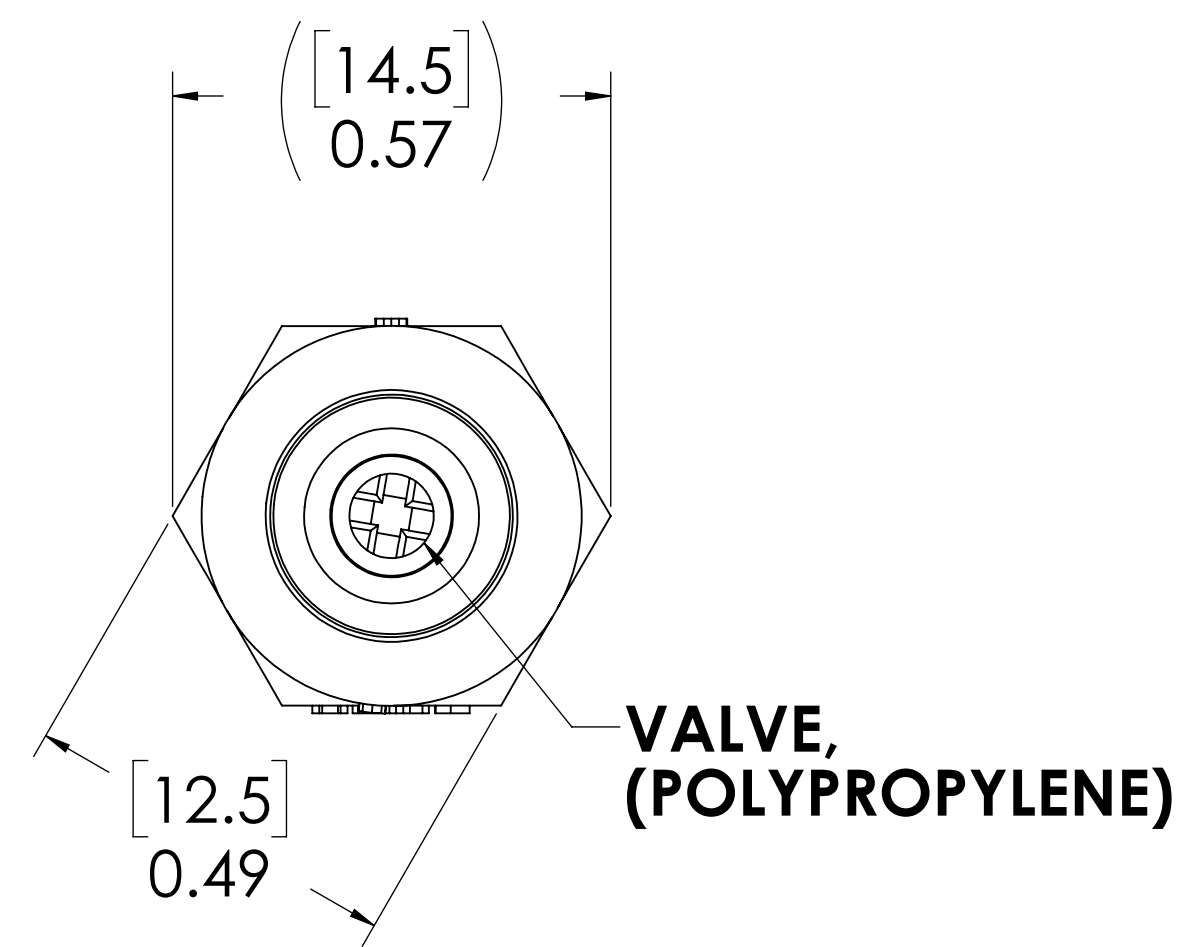

**O-RING,
(EPDM)**

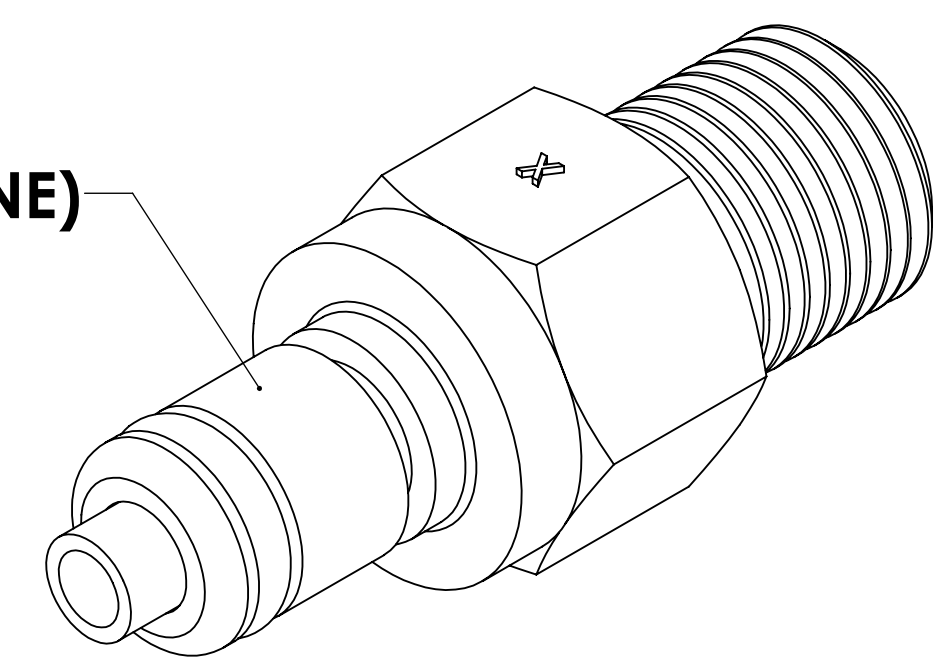
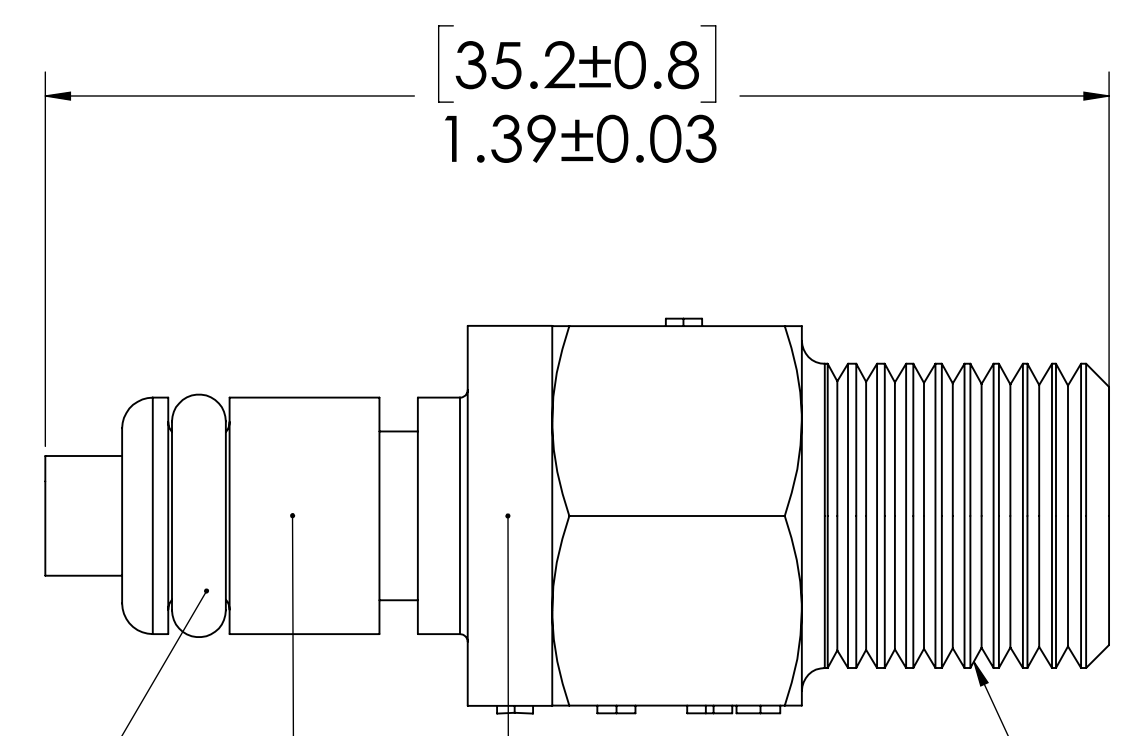

**VALVE SPRING,
INTERNAL
(STAINLESS STEEL)**

**1/8" NPT
(PIPE THREAD)**

**VALVE O-RING,
INTERNAL
(EPDM)**

NOTES:

1. MATERIAL: POLYPROPYLENE
2. COLOR: GREY
3. O-RING MATERIAL: EPDM
4. O-RINGS LUBRICATED WITH FOOD GRADE SILICONE OIL, 350 CST.

FOR REFERENCE ONLY

<small>UNLESS OTHERWISE SPECIFIED: DIMENSIONS ARE IN INCHES TOLERANCES: FRACTIONAL ± 1/32 ANGULAR: MACH ± 0.5 BEND ± 2 ONE PLACE DECIMAL ± 0.1 TWO PLACE DECIMAL ± 0.01 THREE PLACE DECIMAL ± 0.005 TWO PLACE DUAL (mm) [± 0.12]</small>	DRAWN	HRC	1/3/11	
	CHECKED	HRC	1/3/11	
	ENG APPR.	HRC	9/21/18	
	MFG APPR.	BDB	9/21/18	
PRODUCTION	LS	9/21/18		PART NO: 20PPV-PE1-02 DESCRIPTION: LinkTech 20PP Series Male Thread Male, Valved, 1/8"NPT, Molded Grey Color, Polypropylene
<small>PROPRIETARY AND CONFIDENTIAL THE INFORMATION CONTAINED IN THIS DRAWING IS THE SOLE PROPERTY OF LINKTECH LLC. ANY REPRODUCTION OR DISCLOSURE IN PART OR AS A WHOLE WITHOUT THE WRITTEN PERMISSION OF LINKTECH LLC IS STRICTLY PROHIBITED.</small>	COMMENTS:			SIZE DWG. NO. C 20PP200093
				REV A
				SCALE: NTS WEIGHT: SHEET 1 OF 1