

| REVISIONS | | | | | | |
|-----------|------|------|-------|--|------------|----------|
| SHEET | ZONE | REV. | ECO | DESCRIPTION | DATE | APPROVED |
| 1 | ALL | A | 50253 | UPDATE DWG TO CURRENT FORMAT & STANDARDS | 10/30/2018 | HRC |

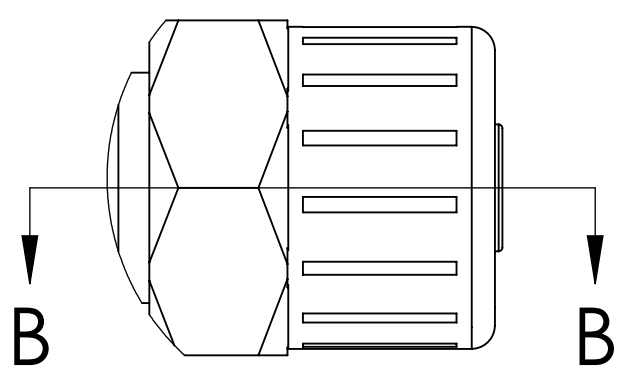

DETAIL A

**PLUG
(POLYPROPYLENE)**

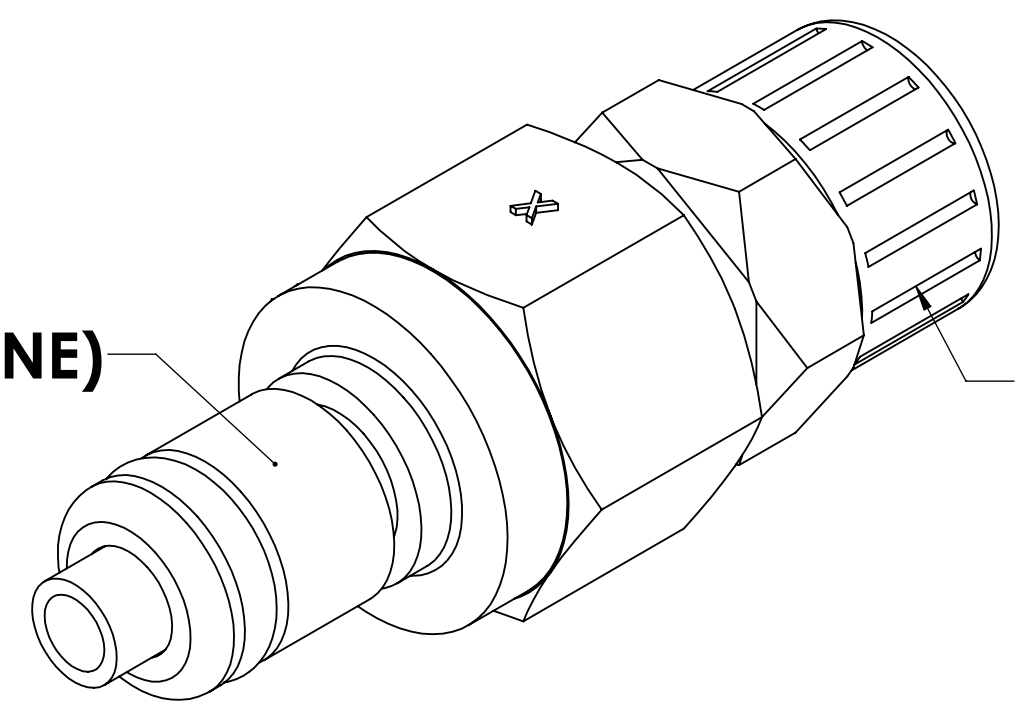

**PTF NUT
(BRASS, NICKEL PLATED)
(PACKAGED SEPARATELY)**

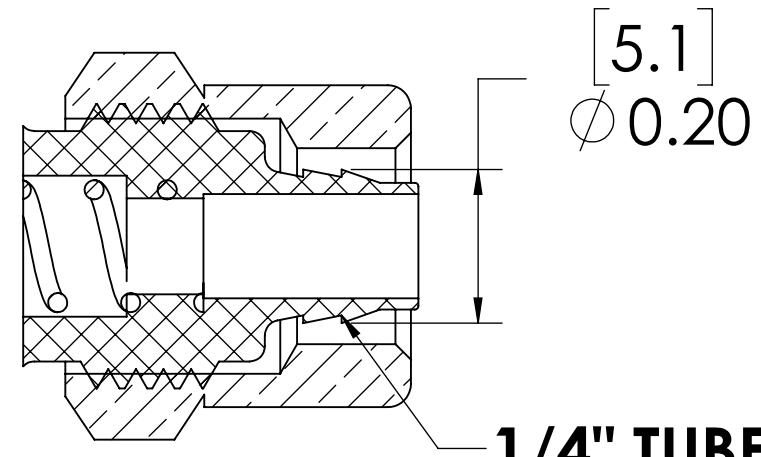

SECTION B-B

1/4" TUBE OD

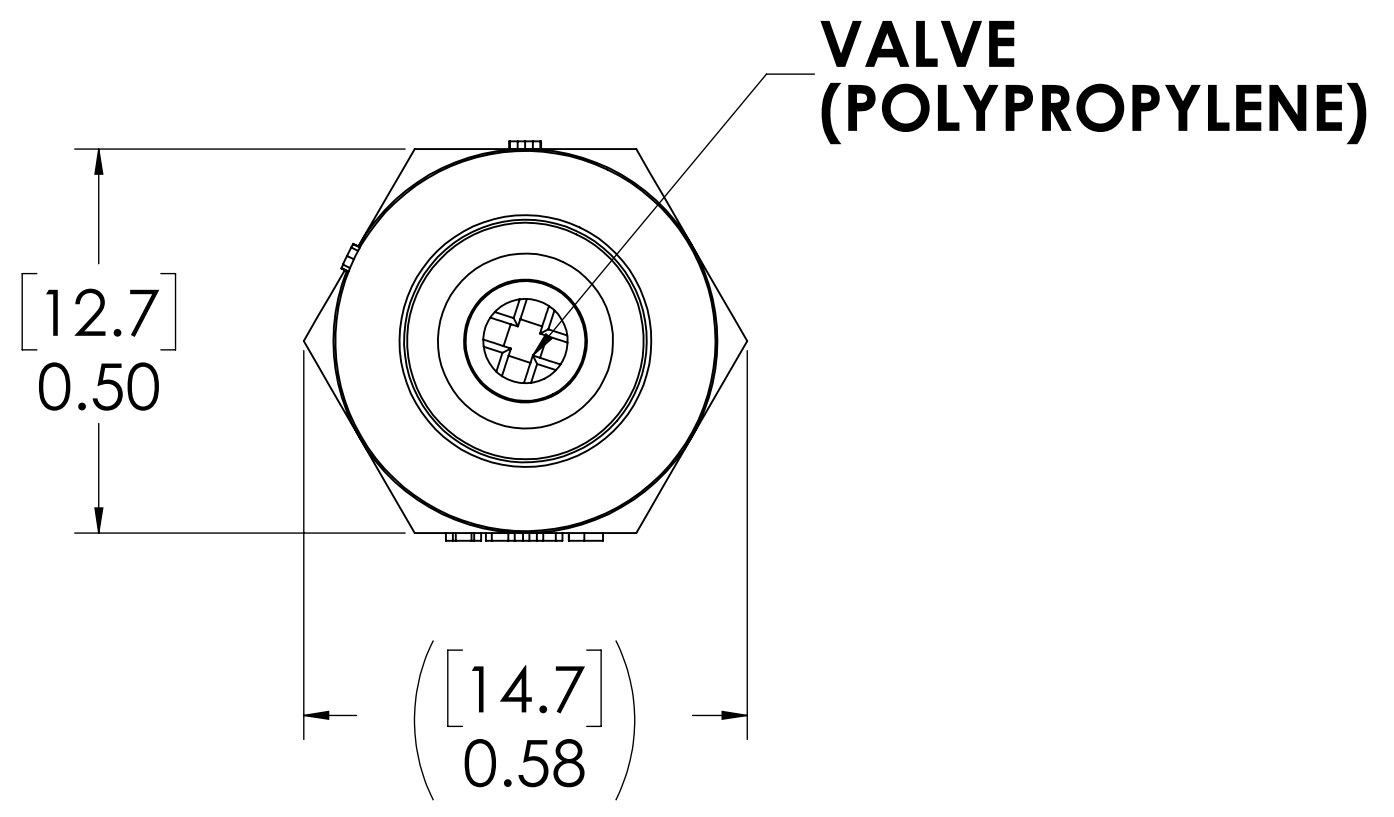

**VALVE
(POLYPROPYLENE)**

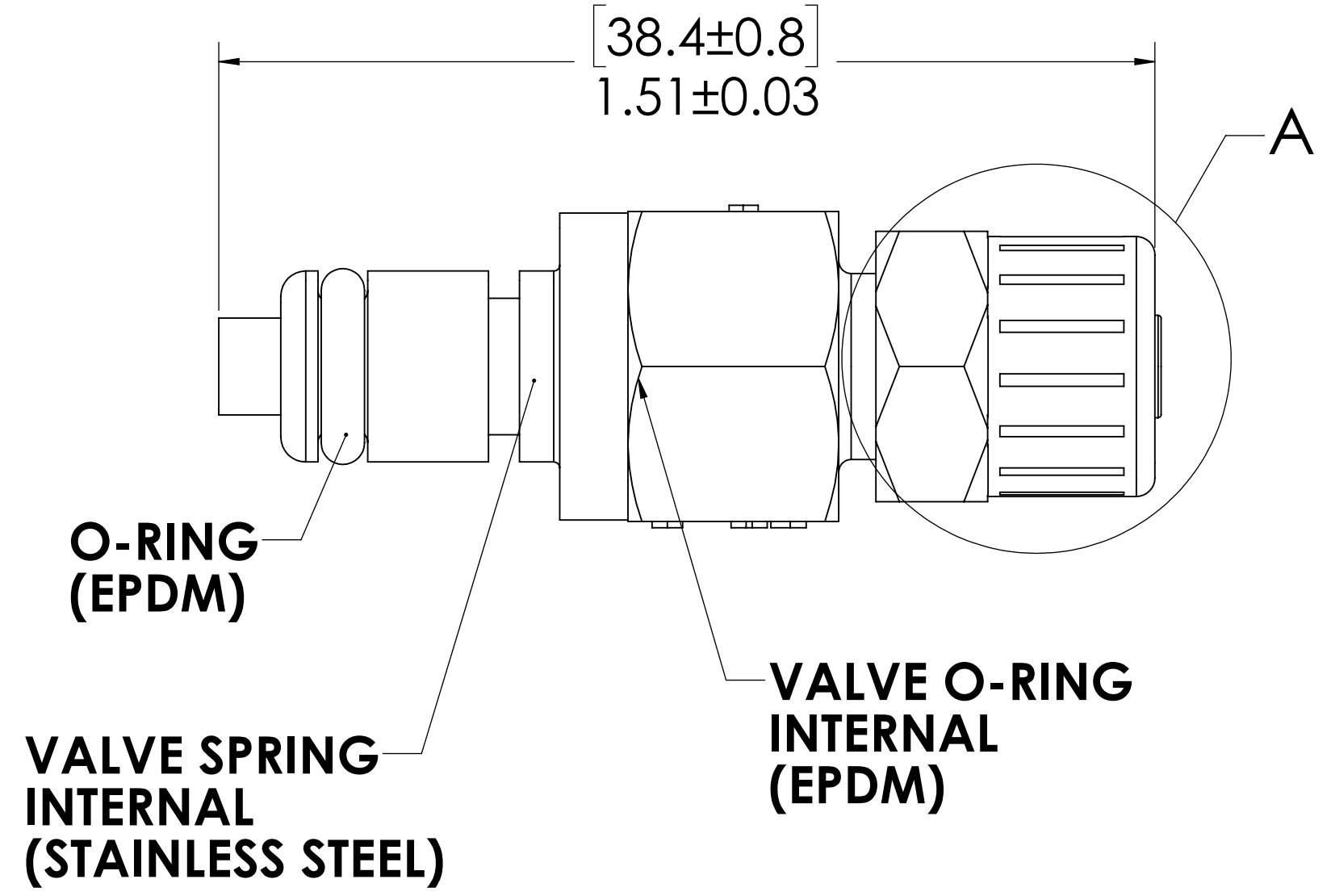

**O-RING
(EPDM)**

**VALVE SPRING
INTERNAL
(STAINLESS STEEL)**

**VALVE O-RING
INTERNAL
(EPDM)**

- NOTES:**
- MATERIAL: POLYPROPYLENE
 - COLOR: GREY
 - O-RING MATERIAL: EPDM
 - O-RINGS LUBRICATED WITH FOOD GRADE SILICONE OIL, 350 CST.

FOR REFERENCE ONLY

| | | | | |
|---|-----------|----------|--|---|
| <small>UNLESS OTHERWISE SPECIFIED: DIMENSIONS ARE IN INCHES TOLERANCES: FRACTIONAL ±1/32 ANGULAR: MACH ±0.5 BEND ±2 ONE PLACE DECIMAL ±0.1 TWO PLACE DECIMAL ±0.01 THREE PLACE DECIMAL ±0.005 TWO PLACE DUAL (mm) [±0.12]</small> | DRAWN | LMP | 6/6/2018 |  PART NO: 20PPV-PE9-04 <small>DESCRIPTION: LinkTech 20PP Series, Inline Plug, Valved, 1/4" PTF, Polypropylene</small> |
| | CHECKED | HRC | 6/6/2018 | |
| | ENG APPR. | HRC | 10/30/18 | |
| | MFG APPR. | BDB | 10/30/18 | |
| PRODUCTION | LS | 10/30/18 | COMMENTS: | <small>SIZE DWG. NO. REV</small> C 20PP200095 A |
| <small>PROPRIETARY AND CONFIDENTIAL</small> <small>THE INFORMATION CONTAINED IN THIS DRAWING IS THE SOLE PROPERTY OF LINKTECH LLC. ANY REPRODUCTION OR DISCLOSURE IN PART OR AS A WHOLE WITHOUT THE WRITTEN PERMISSION OF LINKTECH LLC IS STRICTLY PROHIBITED.</small> | | | <small>SCALE: NTS WEIGHT: SHEET 1 OF 1</small> | |