

REVISIONS						
SHEET	ZONE	REV.	ECO	DESCRIPTION	DATE	APPROVED
1	ALL	A	50242	UPDATE DWG TO CURRENT FORMAT & STANDARDS	11/6/2018	HRC

**LATCH HARDWARE  
(STAINLESS STEEL)**

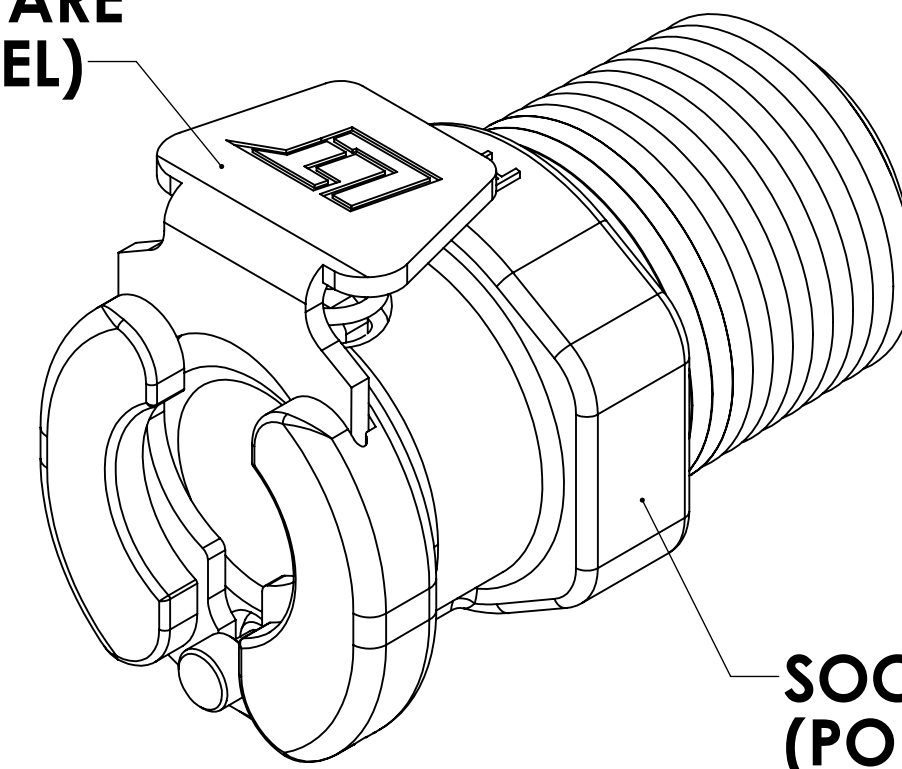

**SOCKET  
(POLYPROPYLENE)**

**VALVE  
(POLYPROPYLENE)**

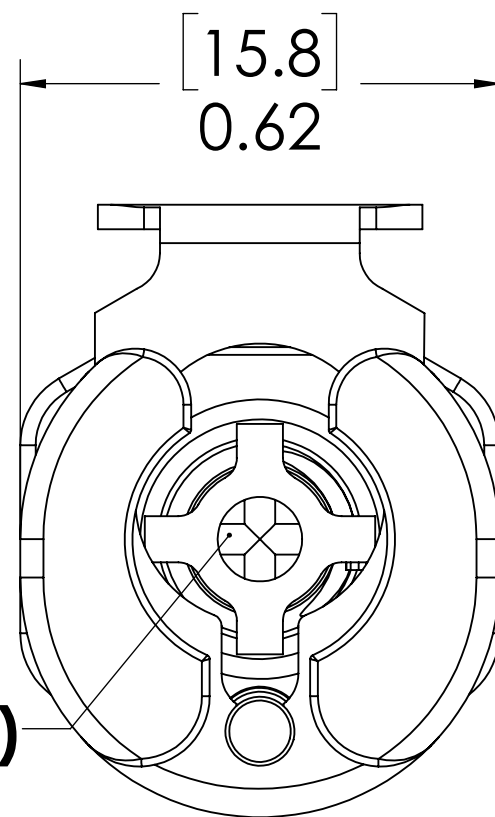

**VALVE SPRING  
INTERNAL  
(STAINLESS STEEL)**

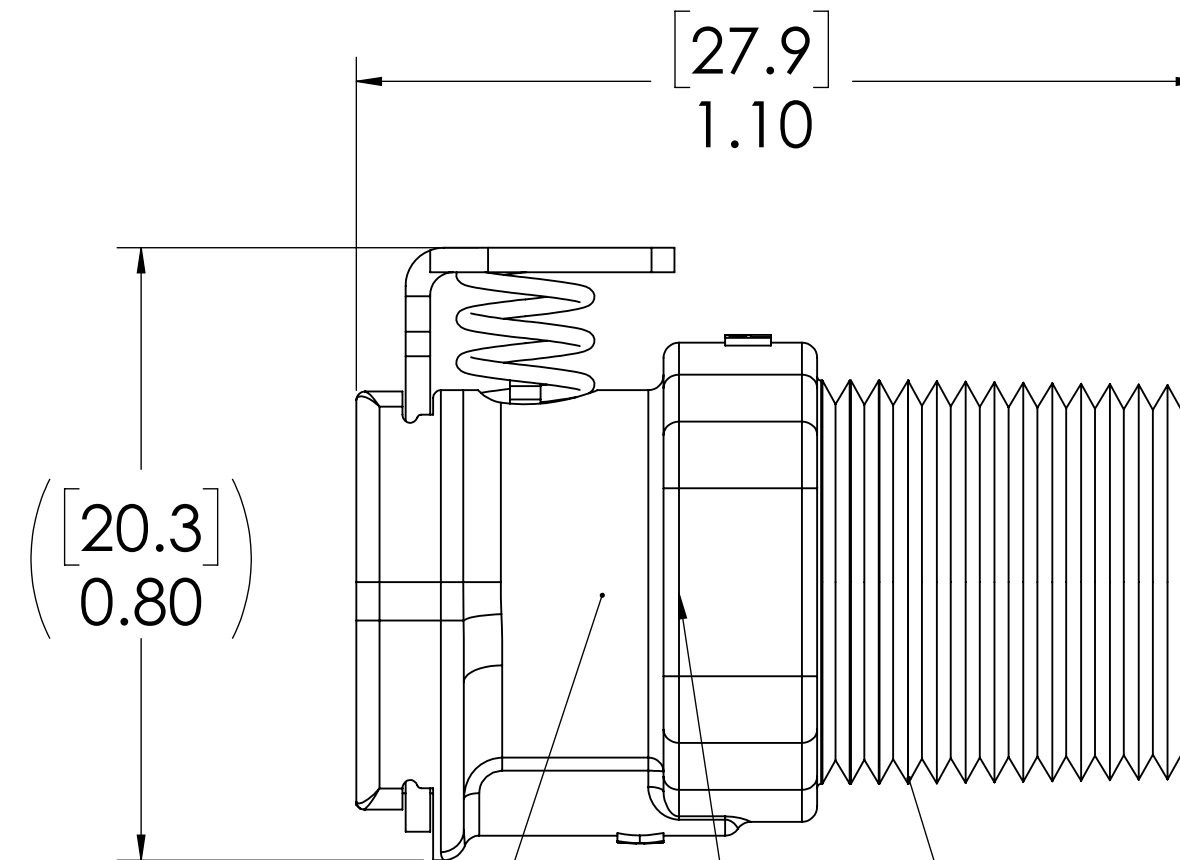

**1/4" NPT THREAD**  
**VALVE O-RING  
INTERNAL  
(EPDM)**

**NOTES:**

- MATERIAL: POLYPROPYLENE
- COLOR: MOLDED ALMOND
- O-RING MATERIAL: EPDM
- O-RINGS LUBRICATED WITH FOOD GRADE SILICONE OIL, 350 CST.

**FOR REFERENCE ONLY**

UNLESS OTHERWISE SPECIFIED: DIMENSIONS ARE IN INCHES TOLERANCES: FRACTIONAL ± 1/32 ANGULAR: MACH ± 0.5 BEND ± 2 ONE PLACE DECIMAL ± 0.1 TWO PLACE DECIMAL ± 0.01 THREE PLACE DECIMAL ± 0.005 TWO PLACE DUAL (mm) [±0.12]	DRAWN	LMP	6/7/2018	
	CHECKED	HRC	6/7/2018	
	ENG APPR.	HRC	11/6/18	
	MFG APPR.	BDB	11/6/18	
PRODUCTION	LS	11/6/18		PART NO: <b>20PPV-SE1-04MALD</b> DESCRIPTION: <b>LinkTech 20PP Series, Male Thread Socket, Valved, 1/4" NPT, Molded Almond Color, Polypropylene</b>
PROPRIETARY AND CONFIDENTIAL THE INFORMATION CONTAINED IN THIS DRAWING IS THE SOLE PROPERTY OF LINKTECH LLC. ANY REPRODUCTION OR DISCLOSURE IN PART OR AS A WHOLE WITHOUT THE WRITTEN PERMISSION OF LINKTECH LLC IS STRICTLY PROHIBITED.	COMMENTS:			SIZE DWG. NO. REV <b>C 20PP200207 A</b>
SCALE: NTS		WEIGHT:		SHEET 1 OF 1