

REVISIONS						
SHEET	ZONE	REV.	ECO	DESCRIPTION	DATE	APPROVED
1	ALL	A	50253	2017 FORMAT UPDATE	7/26/2018	HRC

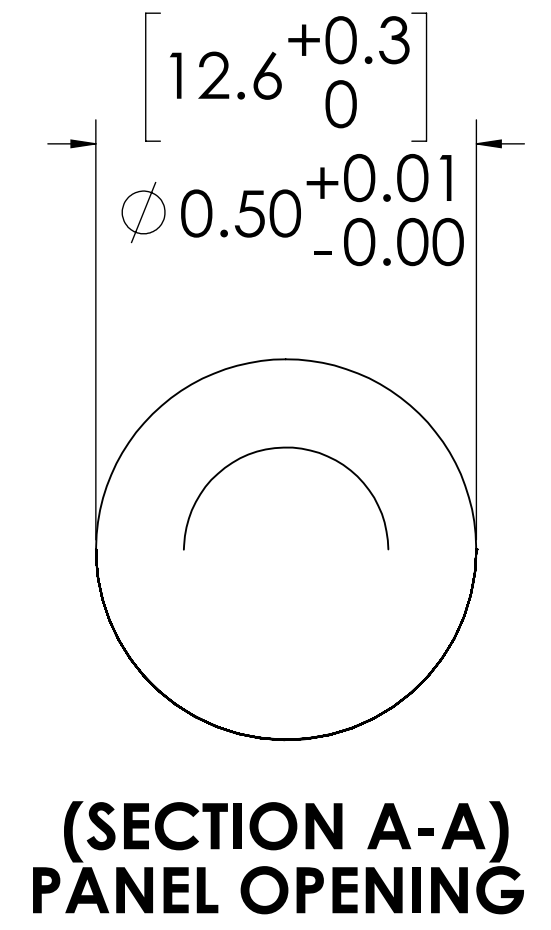
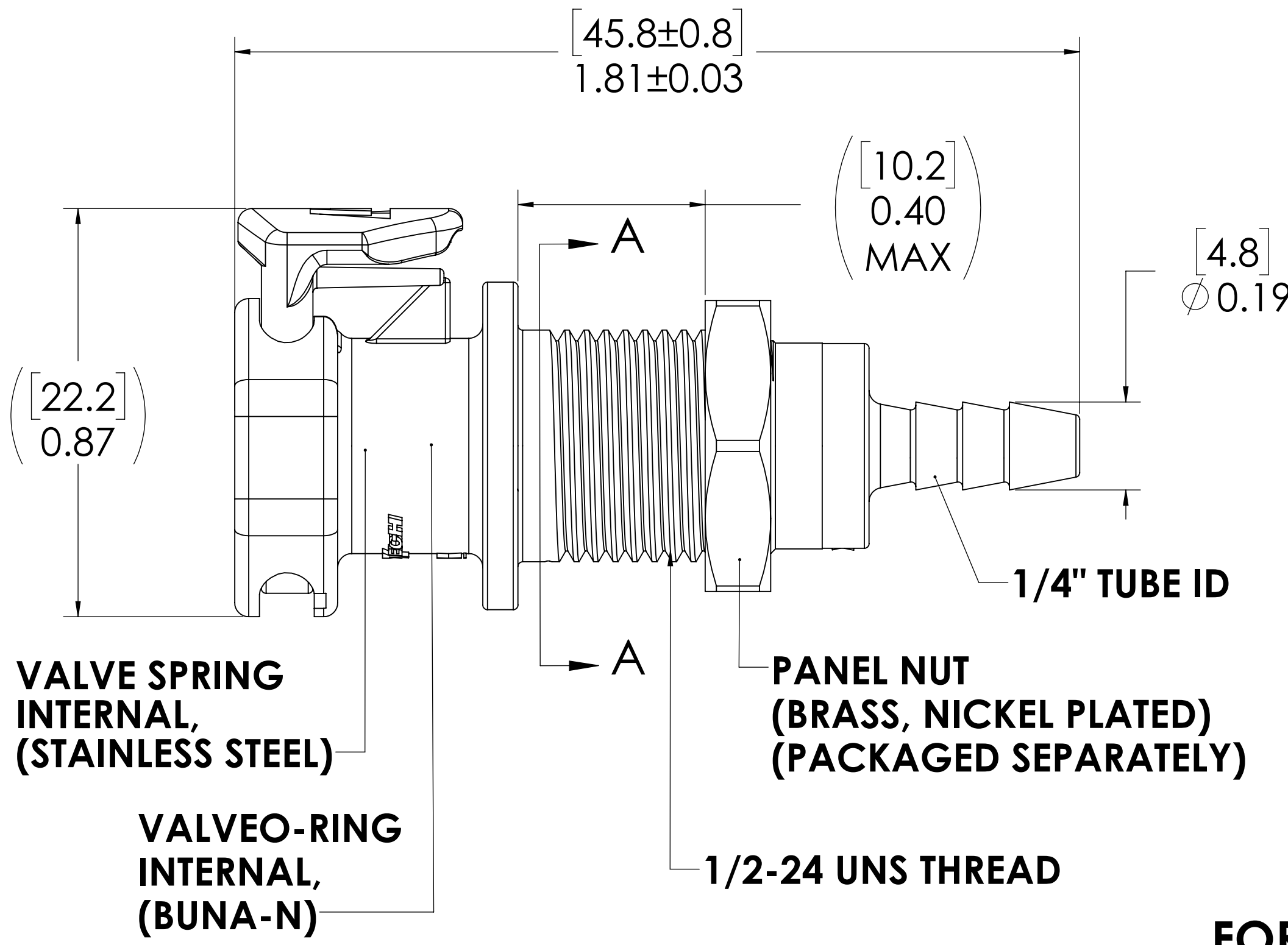
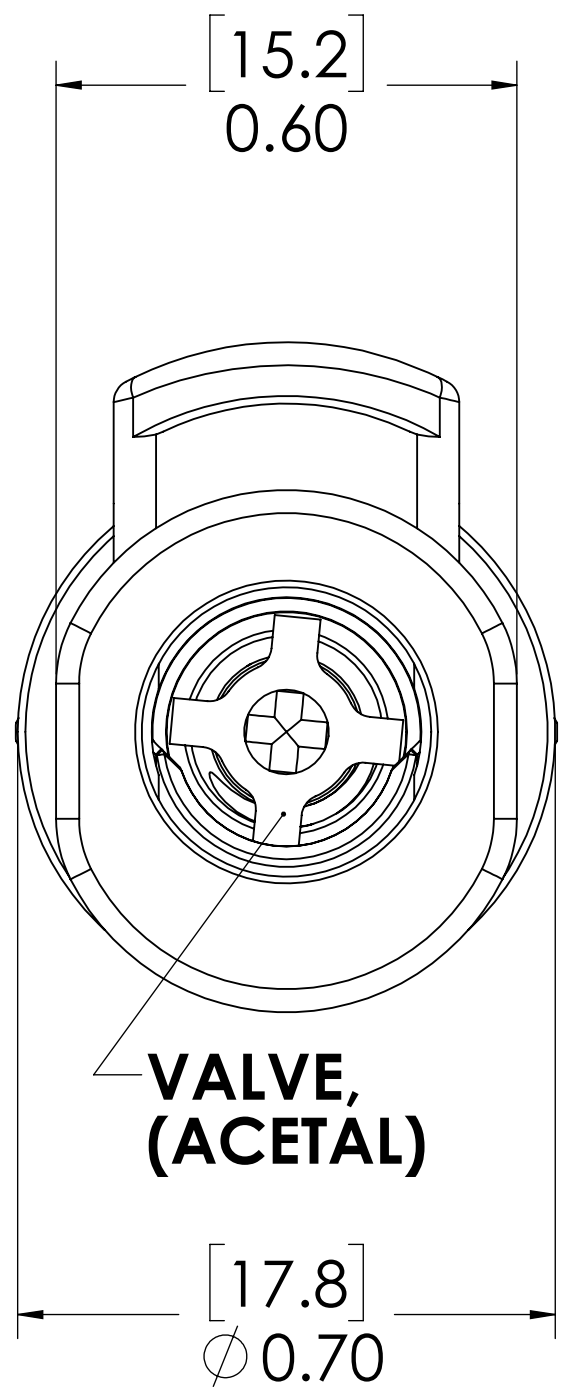
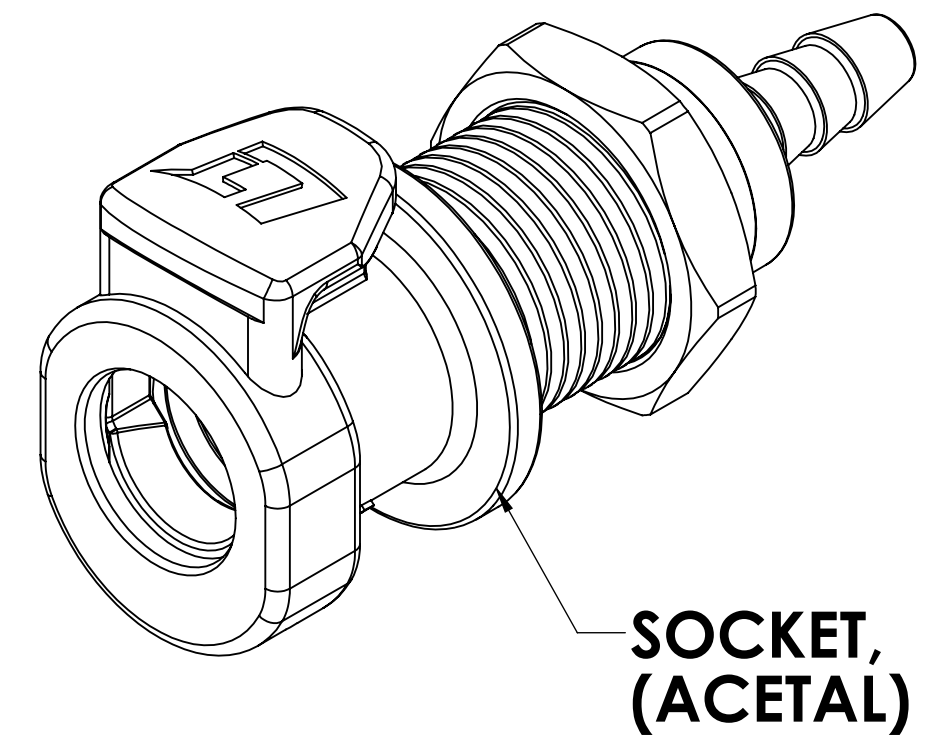

- NOTES:**
- MATERIAL: ACETAL
 - COLOR: NATURAL WHITE
 - O-RING MATERIAL: BUNA-N
 - O-RINGS LUBRICATED WITH FOOD GRADE SILICONE OIL, 350 CST.

FOR REFERENCE ONLY

<small>UNLESS OTHERWISE SPECIFIED: DIMENSIONS ARE IN INCHES TOLERANCES: FRACTIONAL ±1/32 ANGULAR: MACH ±0.5 BEND ±2 ONE PLACE DECIMAL ±0.1 TWO PLACE DECIMAL ±0.01 THREE PLACE DECIMAL ±0.005 TWO PLACE DUAL (mm) [±0.12]</small>	DRAWN	RDA	7/11/2018	
	CHECKED	HRC	7/11/2018	
	ENG APPR.	HRC	7/26/18	
	MFG APPR.	BDB	7/26/18	
PRODUCTION	LS	7/26/18		PART NO: 30ACV-SB3-02 DESCRIPTION: LinkTech 30AC Series Panel Mt. Female Valved, 125 HB, Natural Acetal
<small>PROPRIETARY AND CONFIDENTIAL THE INFORMATION CONTAINED IN THIS DRAWING IS THE SOLE PROPERTY OF LINKTECH LLC. ANY REPRODUCTION OR DISCLOSURE IN PART OR AS A WHOLE WITHOUT THE WRITTEN PERMISSION OF LINKTECH LLC IS STRICTLY PROHIBITED.</small>	COMMENTS:			SCALE: NTS WEIGHT: SHEET 1 OF 1