

REVISIONS						
SHEET	ZONE	REV.	ECO	DESCRIPTION	DATE	APPROVED
1	ALL	A	50253	UPDATE DWG TO CURRENT FORMAT & STANDARDS	10/4/2018	HRC

**PLUG
(ACETAL)**

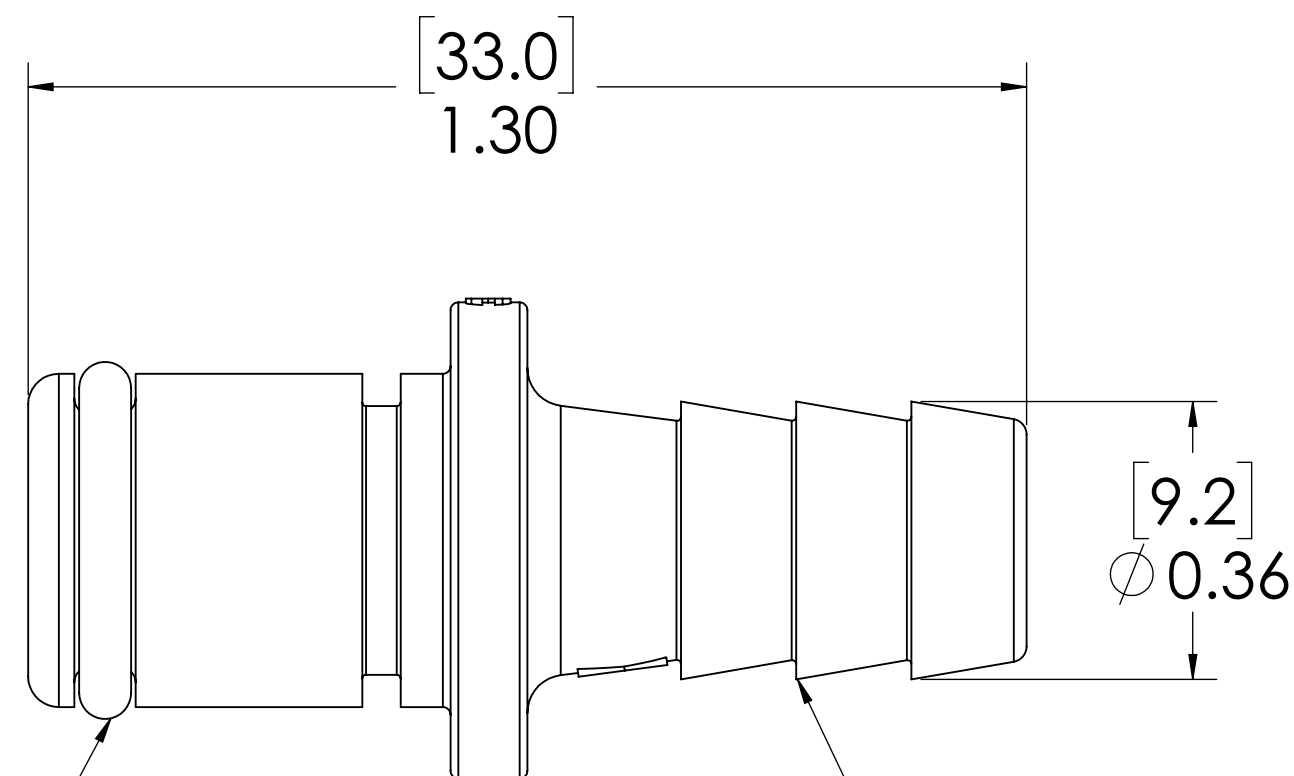
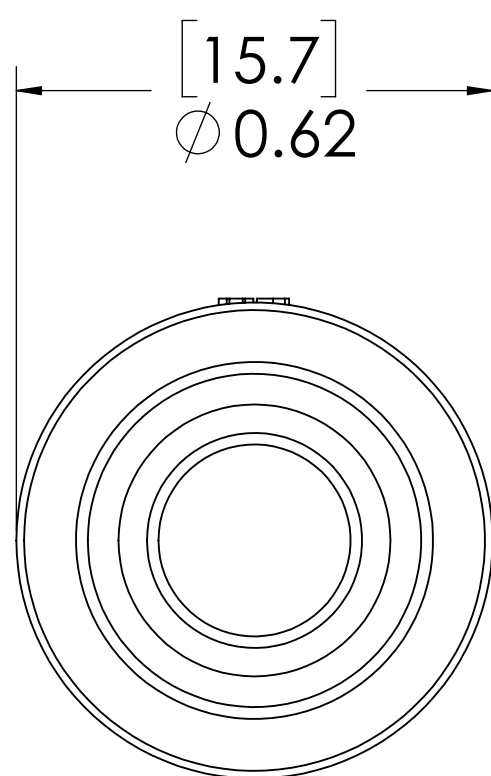
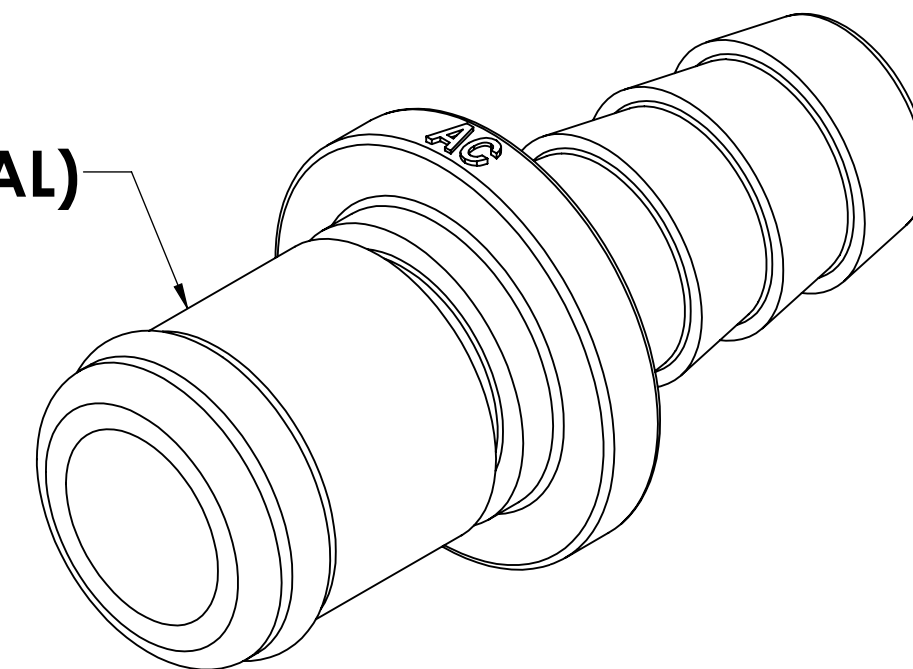

**O-RING
(BUNA-N)**

5/16 TUBE ID

NOTES:

1. MATERIAL: ACETAL
2. COLOR: NATURAL WHITE
3. O-RING MATERIAL: BUNA-N
4. O-RINGS LUBRICATED WITH FOOD GRADE SILICONE OIL, 350 CST.

FOR REFERENCE ONLY

<small>UNLESS OTHERWISE SPECIFIED: DIMENSIONS ARE IN INCHES TOLERANCES: FRACTIONAL ± 1/32 ANGULAR: MACH ± 0.5 BEND ± 2 ONE PLACE DECIMAL ± 0.1 TWO PLACE DECIMAL ± 0.01 THREE PLACE DECIMAL ± 0.005 TWO PLACE DUAL (mm) [± 0.12]</small>	DRAWN	LDM	12/15/17	 PART NO: 40AC-PB2-05
	CHECKED	HRC	12/15/17	
	ENG APPR.	HRC	10/4/18	DESCRIPTION: LinkTech 40AC Series Straight Male, Non-valved, 5/16" HB, Natural Acetal
	MFG APPR.	BDB	10/4/18	
PRODUCTION	LS	10/4/18	SIZE DWG. NO. REV C 40AC400225 A	
<small>PROPRIETARY AND CONFIDENTIAL THE INFORMATION CONTAINED IN THIS DRAWING IS THE SOLE PROPERTY OF LINKTECH LLC. ANY REPRODUCTION OR DISCLOSURE IN PART OR AS A WHOLE WITHOUT THE WRITTEN PERMISSION OF LINKTECH LLC IS STRICTLY PROHIBITED.</small>			<small>COMMENTS:</small>	<small>SCALE: NTS WEIGHT: SHEET 1 OF 1</small>