

REVISIONS						
SHEET	ZONE	REV.	ECO	DESCRIPTION	DATE	APPROVED
ALL	ALL	A	50242	PIN, PN SPRING & FORMAT UPDATE	3/29/2019	HRC

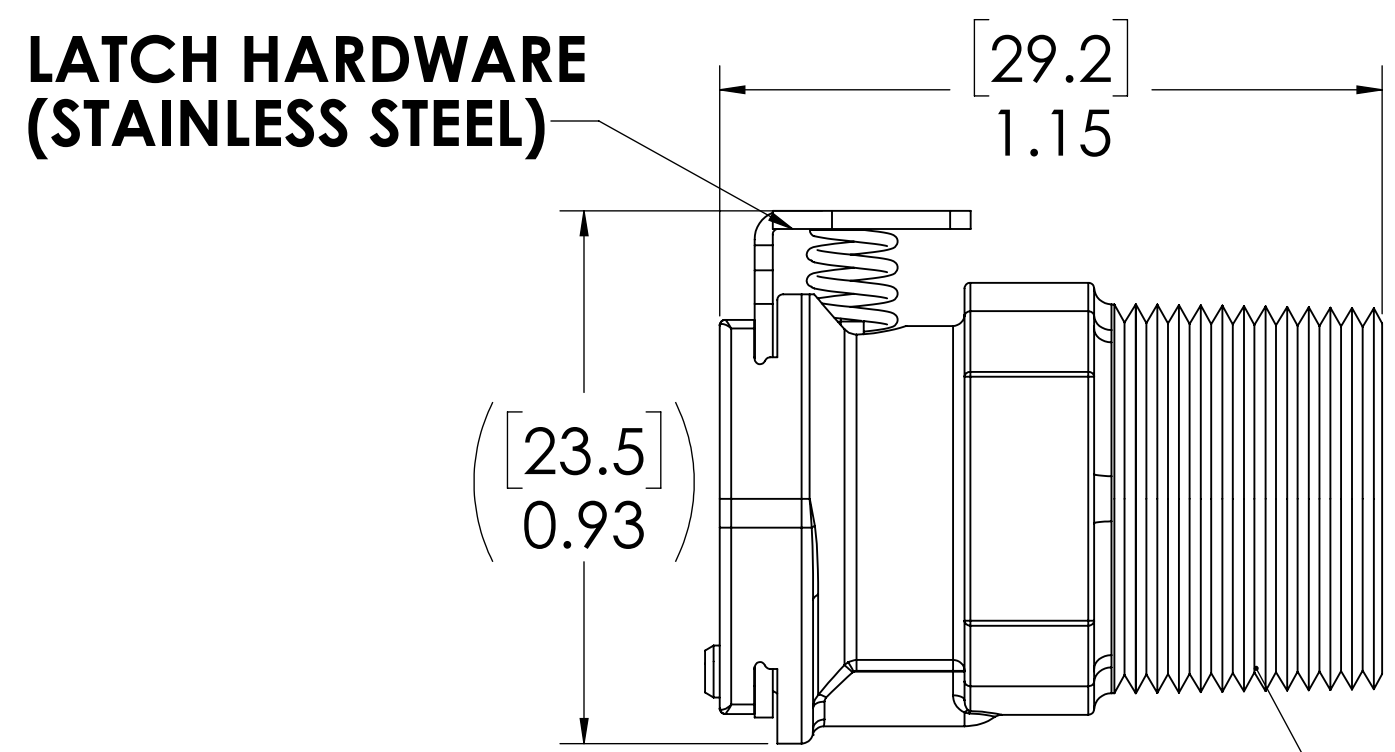
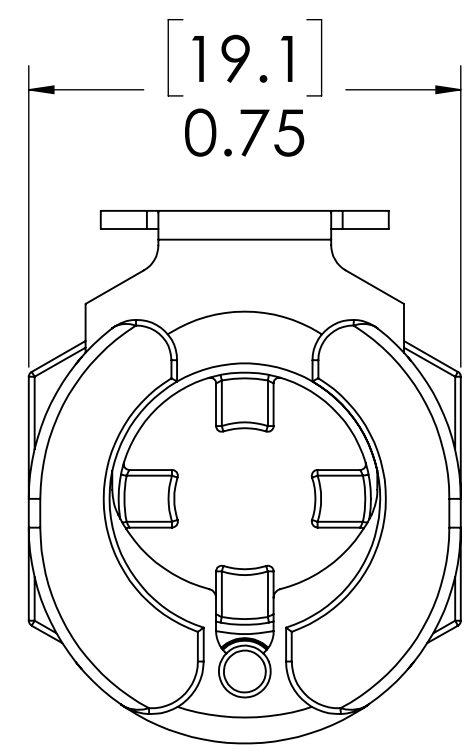
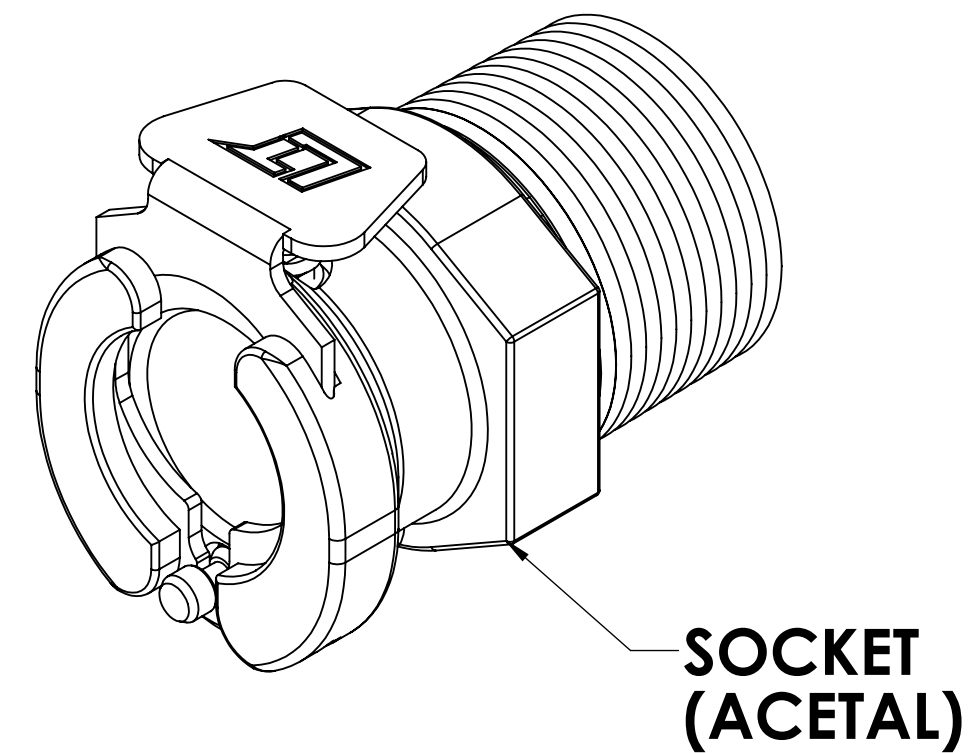

**3/8 NPT THREAD
(PIPE THREAD)**

**LATCH HARDWARE
(STAINLESS STEEL)**

- NOTES:**
1. MATERIAL: ACETAL
 2. COLOR: NATURAL WHITE
 3. O-RING MATERIAL: BUNA-N
 4. O-RINGS LUBRICATED WITH FOOD GRADE SILICONE OIL, 350 CST.

FOR REFERENCE ONLY

<small>UNLESS OTHERWISE SPECIFIED: DIMENSIONS ARE IN INCHES TOLERANCES: FRACTIONAL ± 1/32 ANGULAR, MACH ± 0.5 BEND ± 2 ONE PLACE DECIMAL ± 0.1 TWO PLACE DECIMAL ± 0.01 THREE PLACE DECIMAL ± 0.005 TWO PLACE DUAL (mm) [± 0.12]</small>	DRAWN	RDA	3/20/2019	 PART NO: 40AC-S1-06 DESCRIPTION: LinkTech 40AC Series Male Thread Female, Non-valved, 375 MNPT, Natural Acetal
	CHECKED	HRC	3/20/2019	
	ENG APPR.	HRC	3/29/19	
	MFG APPR.	BDB	3/29/19	
PRODUCTION	LS	3/29/19		<small>PROPRIETARY AND CONFIDENTIAL</small> <small>THE INFORMATION CONTAINED IN THIS DRAWING IS THE SOLE PROPERTY OF LINKTECH LLC. ANY REPRODUCTION OR DISCLOSURE IN PART OR AS A WHOLE WITHOUT THE WRITTEN PERMISSION OF LINKTECH LLC IS STRICTLY PROHIBITED.</small>
<small>COMMENTS:</small>		<small>SIZE</small> DWG. NO. C 40AC400270	<small>REV</small> A	<small>SCALE: NTS</small> <small>WEIGHT:</small> <small>SHEET 1 OF 1</small>