

REVISIONS						
SHEET	ZONE	REV.	ECO	DESCRIPTION	DATE	APPROVED
1	ALL	A	50253	DRAWING RELEASE	7/27/2018	HRC

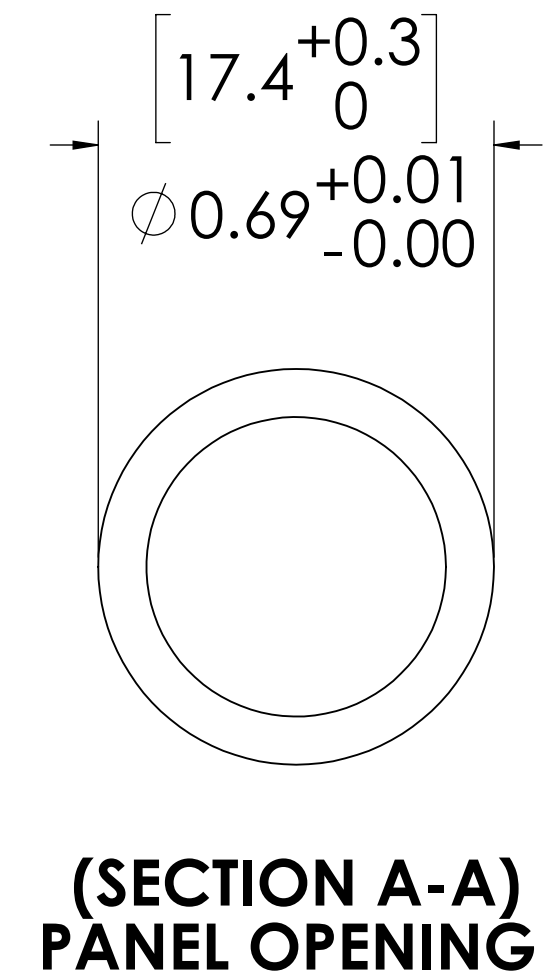
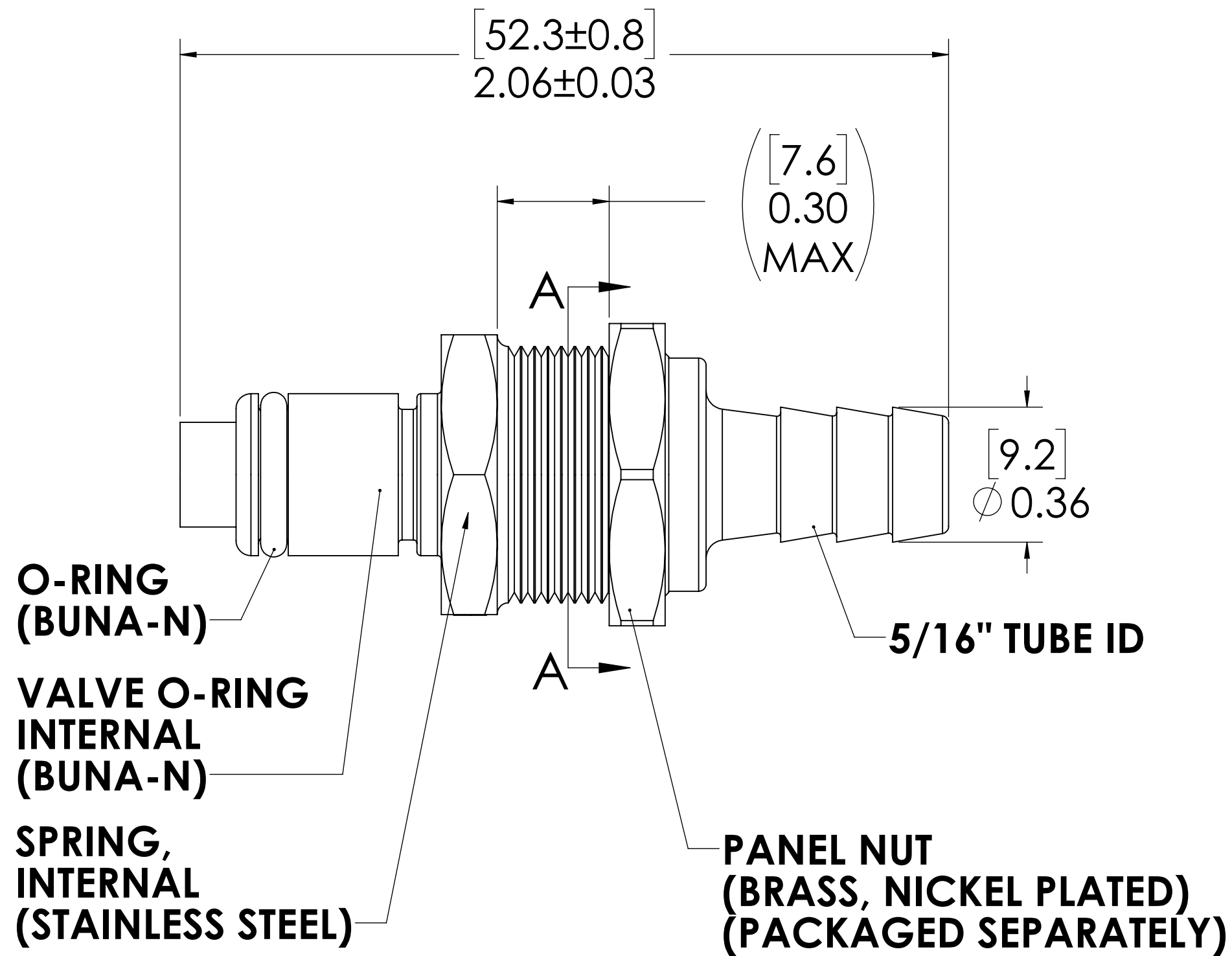
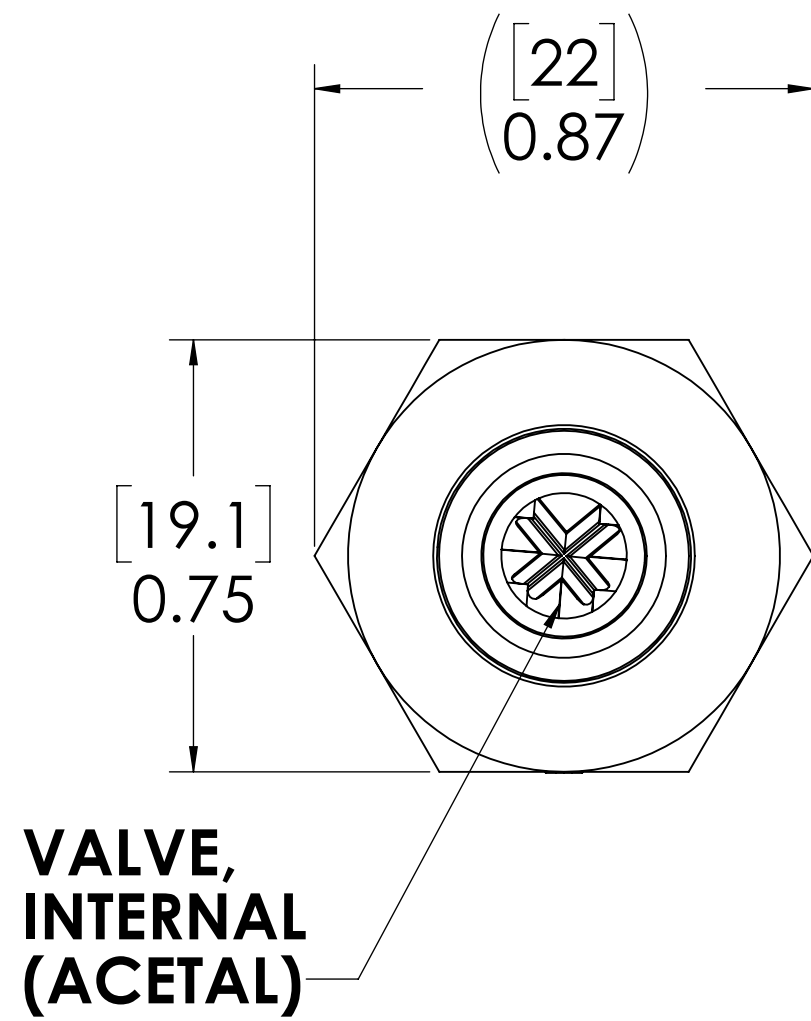
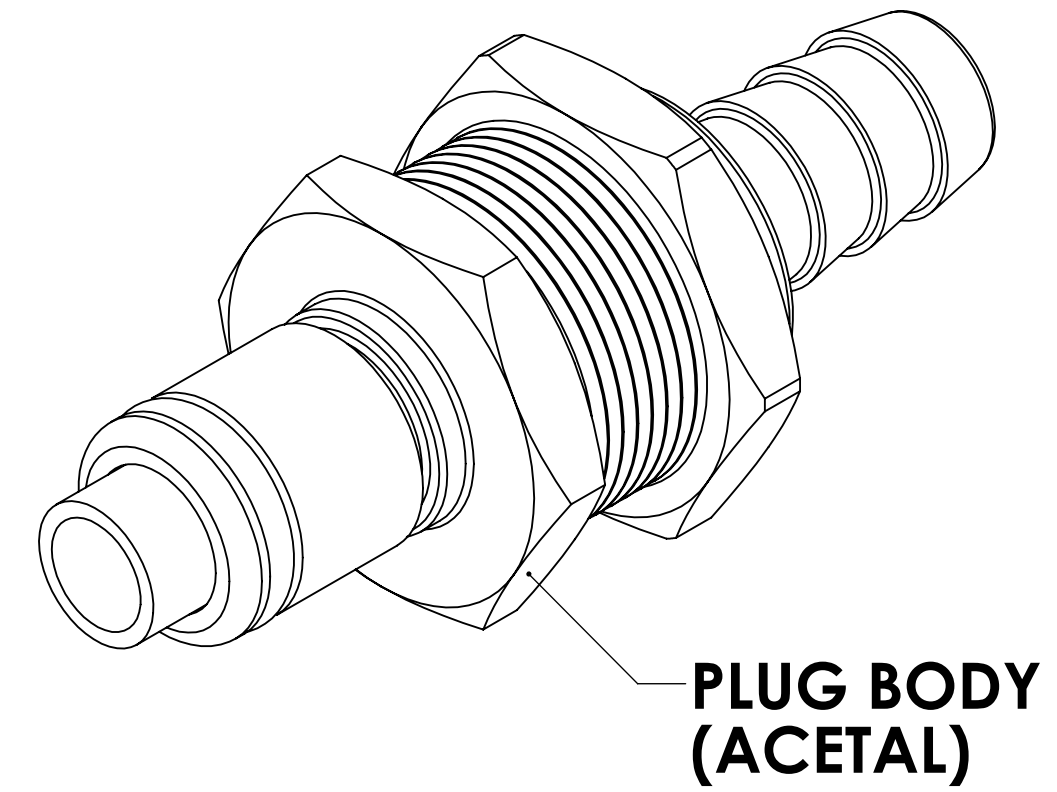

- NOTES:**
- MATERIAL: ACETAL
 - COLOR: NATURAL WHITE
 - O-RING MATERIAL: BUNA-N
 - O-RINGS LUBRICATED WITH FOOD GRADE SILICONE OIL, 350 CST.

FOR REFERENCE ONLY

UNLESS OTHERWISE SPECIFIED:		NAME	DATE	
DIMENSIONS ARE IN INCHES		DRAWN	RDA	
TOLERANCES:		CHECKED	HRC	1/26/18
FRACTIONAL ± 1/32		ENG APPR.	HRC	7/27/18
ANGULAR: MACH ± 0.5 BEND ± 2		MFG APPR.	BDB	7/27/18
ONE PLACE DECIMAL ± 0.1		PRDUCTION	LS	7/27/18
TWO PLACE DECIMAL ± 0.01		COMMENTS:		
THREE PLACE DECIMAL ± 0.005				
TWO PLACE DUAL (mm) [± 0.12]				
PROPRIETARY AND CONFIDENTIAL THE INFORMATION CONTAINED IN THIS DRAWING IS THE SOLE PROPERTY OF LINKTECH LLC. ANY REPRODUCTION OR DISCLOSURE IN PART OR AS A WHOLE WITHOUT THE WRITTEN PERMISSION OF LINKTECH LLC IS STRICTLY PROHIBITED.				
		PART NO: 40ACV-PB3-05 DESCRIPTION: LinkTech 40AC Series Panel Mt. Male, Valved, 5/16" HB, Natural Acetal		
SIZE	DWG. NO.	REV		
C	40AC400262	A		
SCALE: NTS	WEIGHT:	SHEET 1 OF 1		