

REVISIONS						
SHEET	ZONE	REV.	ECO	DESCRIPTION	DATE	APPROVED
1	ALL	A	50242	UPDATE DWG TO CURRENT FORMAT & STANDARDS	10/12/2018	HRC

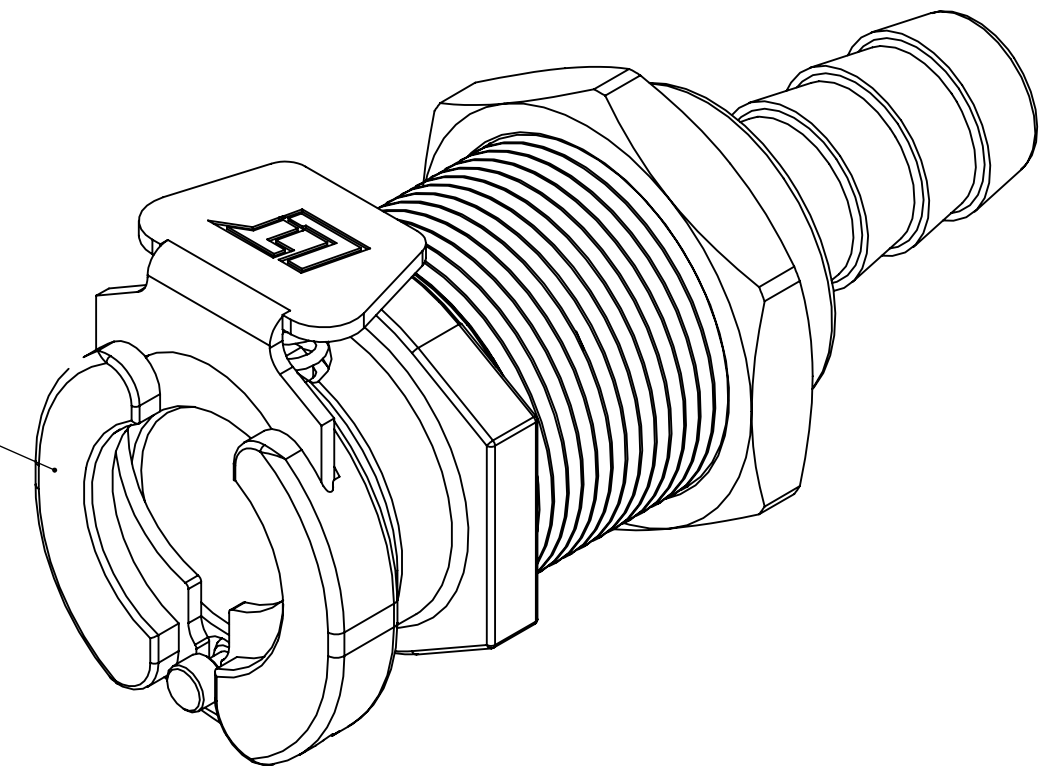

**SOCKET  
(ACETAL)**

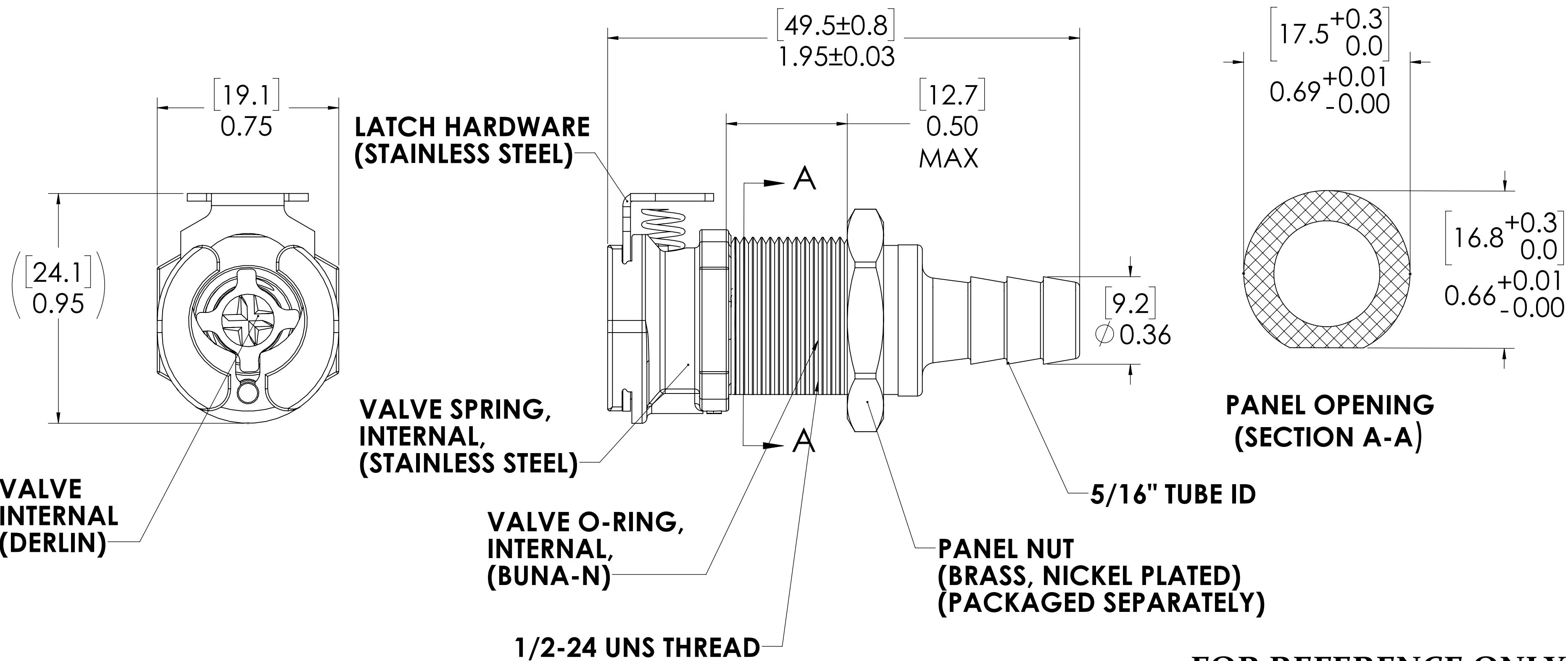

**NOTES:**

- MATERIAL: ACETAL
- COLOR: NATURAL WHITE
- O-RING MATERIAL: BUNA-N
- O-RINGS LUBRICATED WITH FOOD GRADE SILICONE OIL, 350 CST.

**FOR REFERENCE ONLY**

<small>UNLESS OTHERWISE SPECIFIED:          DIMENSIONS ARE IN INCHES          TOLERANCES:          FRACTIONAL <math>\pm 1/32</math>          ANGULAR: MACH <math>\pm 0.5</math> BEND <math>\pm 2</math>          ONE PLACE DECIMAL <math>\pm 0.1</math>          TWO PLACE DECIMAL <math>\pm 0.01</math>          THREE PLACE DECIMAL <math>\pm 0.005</math>          TWO PLACE DUAL (mm) <math>[\pm 0.12]</math></small>	DRAWN	LDM	12/1/17	
	CHECKED	HRC	12/1/17	
	ENG APPR.	HRC	10/12/18	
	MFG APPR.	BDB	10/12/18	
PRODUCTION	LS	10/12/18		<b>PART NO: 40ACV-SB3-05</b> <b>DESCRIPTION: LinkTech 40AC Series Panel Mt. Female, Valved, 5/16" HB, Natural Acetal</b>
<small>PROPRIETARY AND CONFIDENTIAL          THE INFORMATION CONTAINED IN THIS DRAWING IS THE SOLE PROPERTY OF LINKTECH LLC. ANY REPRODUCTION OR DISCLOSURE IN PART OR AS A WHOLE WITHOUT THE WRITTEN PERMISSION OF LINKTECH LLC IS STRICTLY PROHIBITED.</small>				SIZE DWG. NO. REV <b>C 40AC400245 A</b>
SCALE: NTS WEIGHT:			SHEET 1 OF 1	