

REVISIONS						
SHEET	ZONE	REV.	ECO	DESCRIPTION	DATE	APPROVED
ALL	ALL	A	50253	UPDATE DRAWING FORMAT	8/18/17	HRC

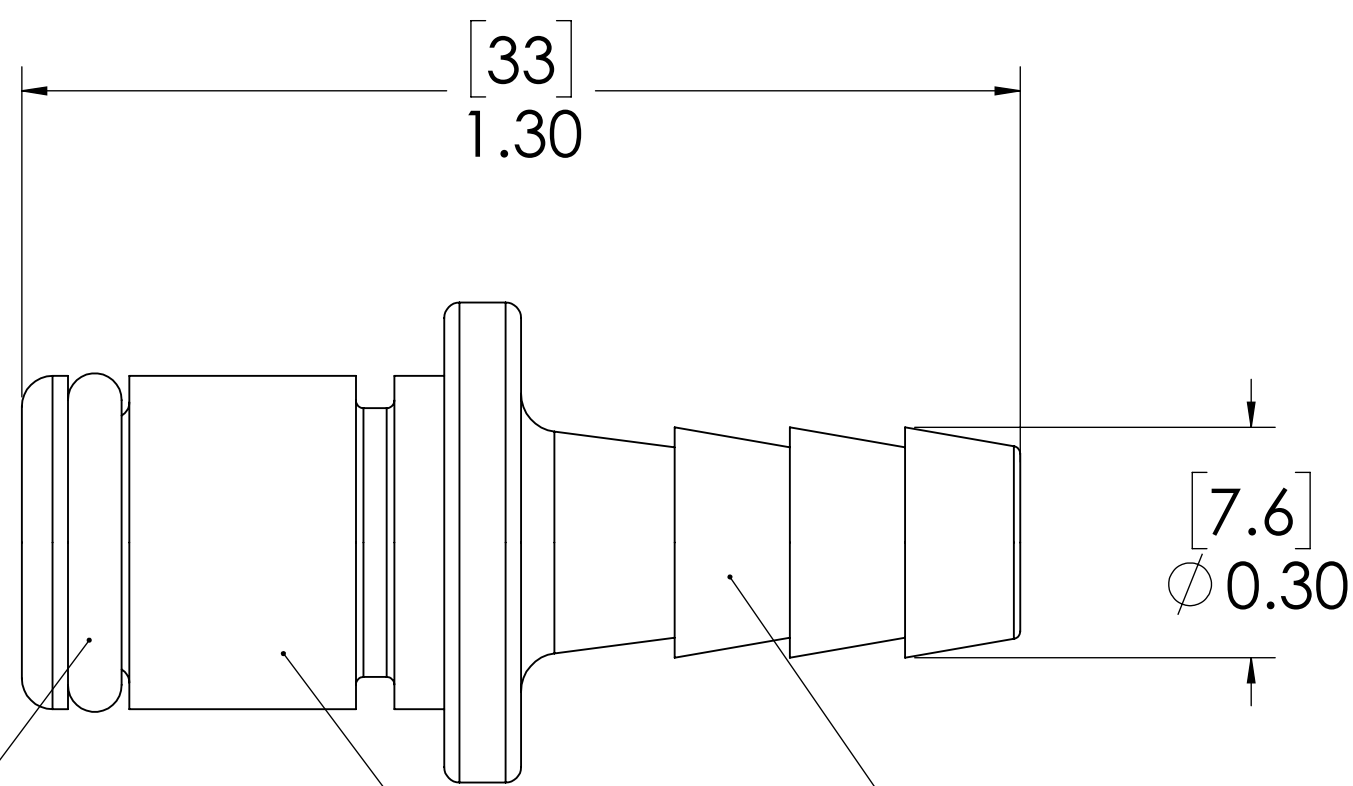
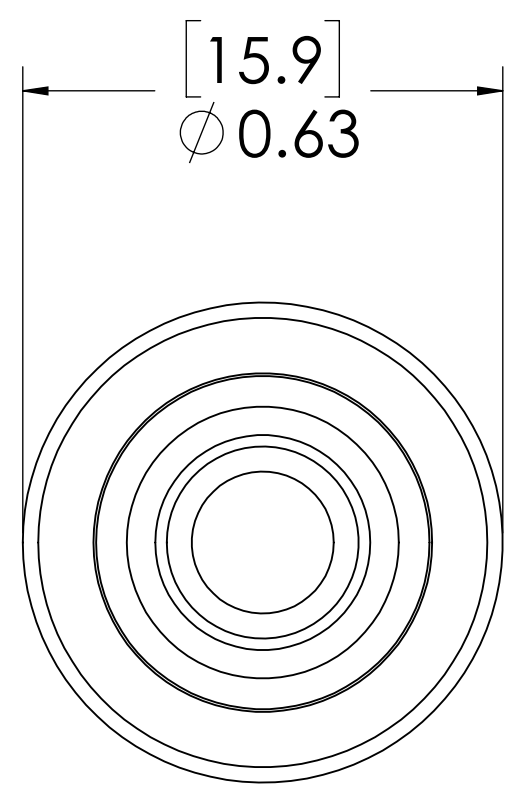
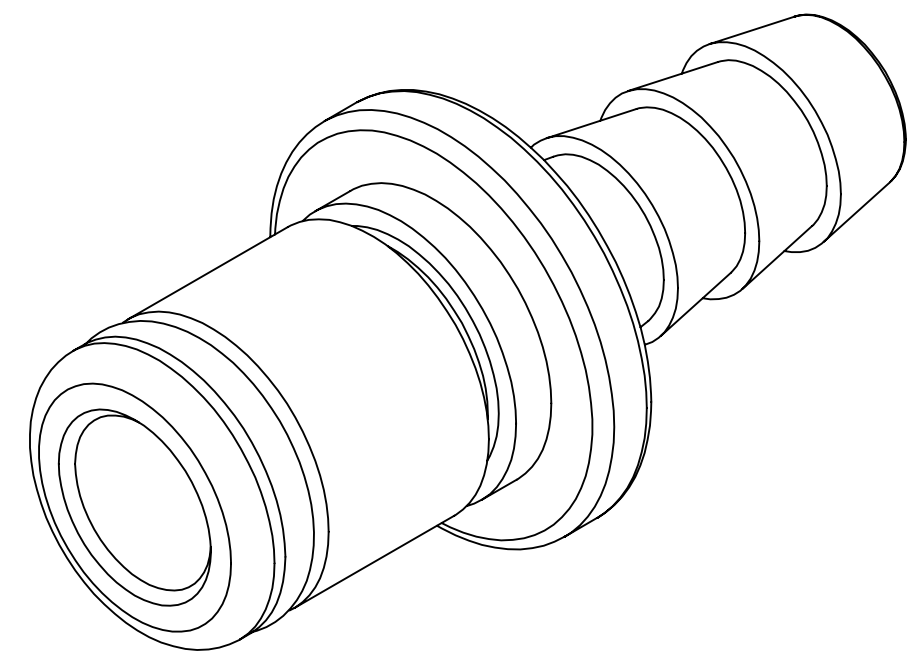

O-RING,
(BUNA-N)

PLUG,
(BRASS, NICKEL AND
CHROME PLATED)

FOR REFERENCE ONLY

NOTES:

- MATERIAL: BRASS
- COLOR: CHROME
- O-RING MATERIAL: BUNA-N
- O-RINGS LUBRICATED WITH FOOD GRADE SILICONE OIL, 350 CST.

<small>UNLESS OTHERWISE SPECIFIED: DIMENSIONS ARE IN INCHES TOLERANCES: FRACTIONAL ± 1/32 ANGULAR, MACH ± 0.5 BEND ± 2 ONE PLACE DECIMAL ± 0.1 TWO PLACE DECIMAL ± 0.01 THREE PLACE DECIMAL ± 0.005 TWO PLACE DUAL (mm) [± 0.12]</small>	DRAWN	CKE	8/9/17	
	CHECKED	XXX	XX/XX/XX	
	ENG APPR.	HRC	8/18/17	
	MFG APPR.	BDB	8/18/17	
<small>PROPRIETARY AND CONFIDENTIAL</small>	Q.A.	JJB	8/18/17	PART NO: 40CB-PB2-04
<small>THE INFORMATION CONTAINED IN THIS DRAWING IS THE SOLE PROPERTY OF LINKTECH LLC. ANY REPRODUCTION OR DISCLOSURE IN PART OR AS A WHOLE WITHOUT THE WRITTEN PERMISSION OF LINKTECH LLC IS STRICTLY PROHIBITED.</small>	COMMENTS:			DESCRIPTION: 250 HB NV INLINE CB PLUG 40 SERIES
	SIZE	DWG. NO.	REV	
	C	40CB400221	A	
	SCALE: NTS	WEIGHT:		SHEET 1 OF 1