

REVISIONS						
SHEET	ZONE	REV.	ECO	DESCRIPTION	DATE	APPROVED
1	ALL	A	50242	UPDATE DWG TO CURRENT FORMAT & STANDARDS	10/18/2018	HRC

**LATCH HARDWARE
(STAINLESS STEEL)**

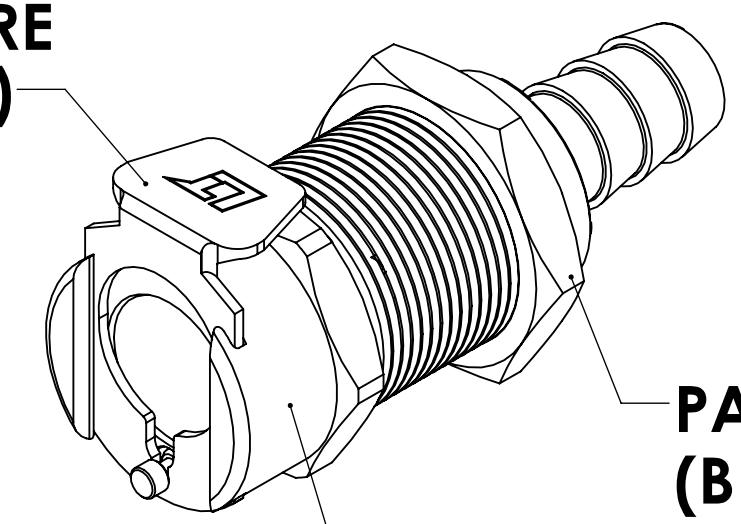

**PANEL NUT
(BRASS, NICKEL PLATED)
(PACKAGED SEPARATELY)**

**SOCKET
(BRASS, NICKEL &
CHROME PLATED)**

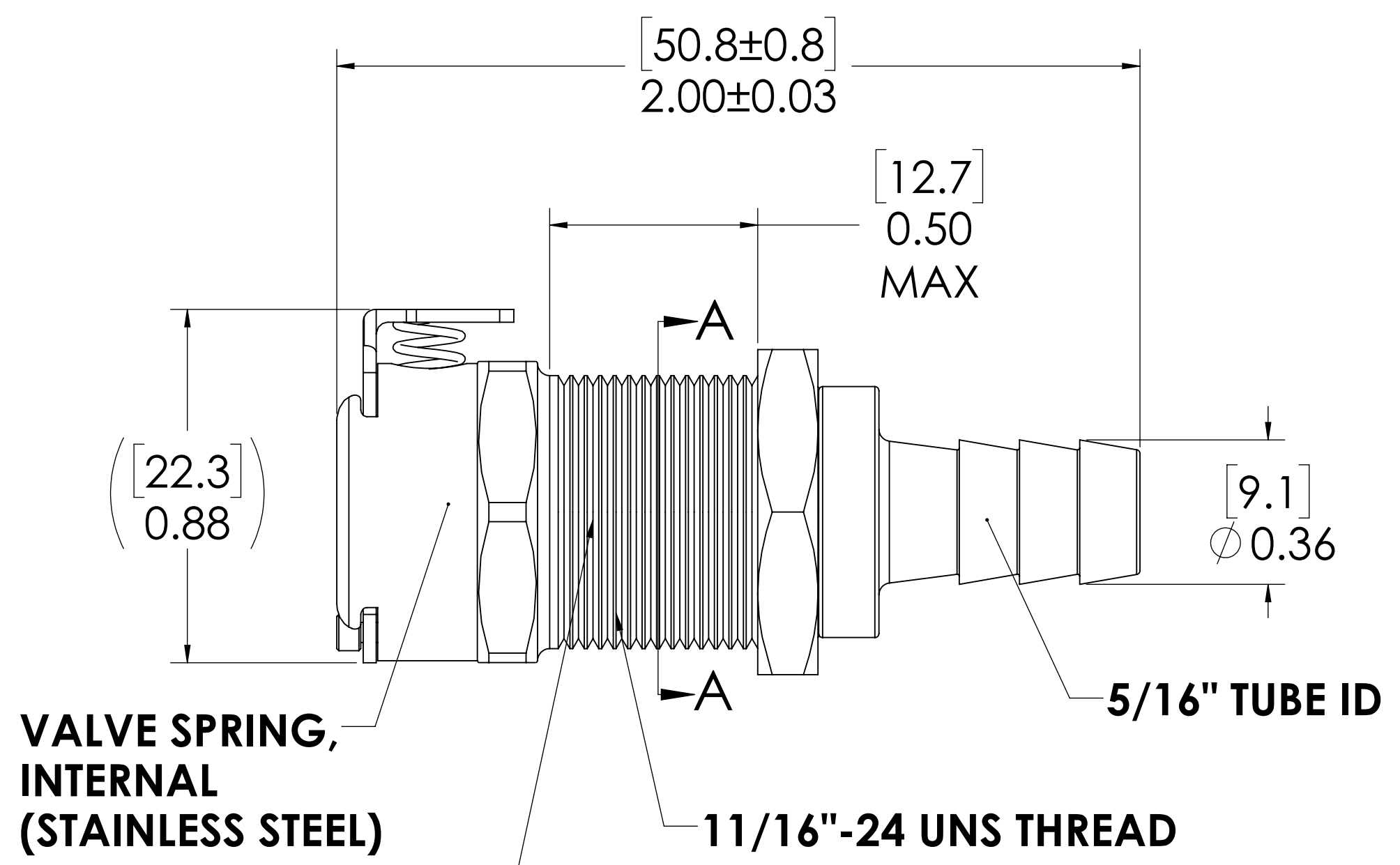
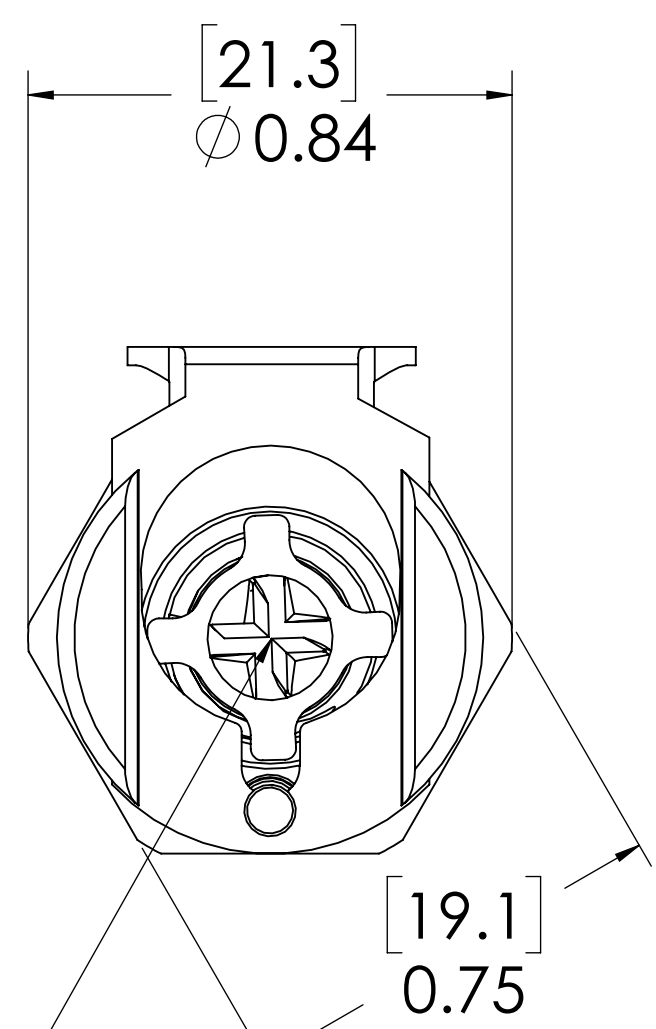

**VALVE SPRING,
INTERNAL
(STAINLESS STEEL)**

**VALVE O-RING,
INTERNAL
(BUNA-N)**

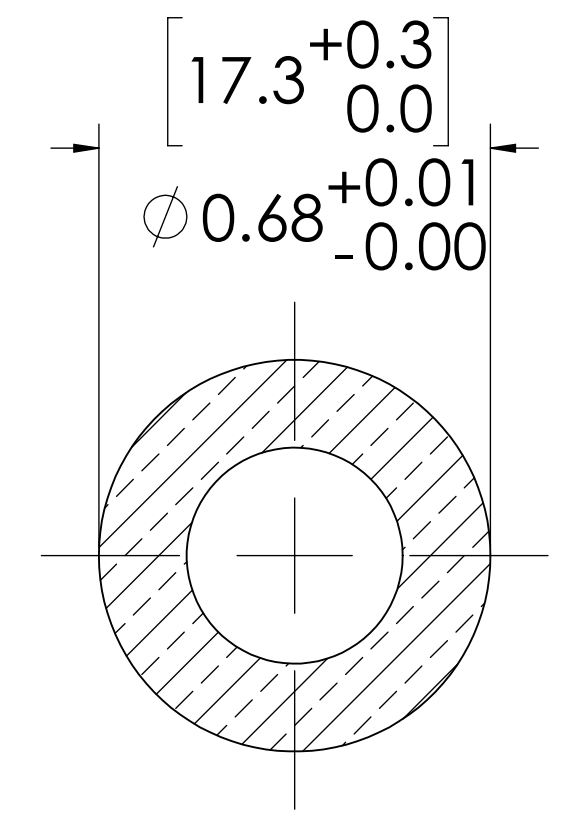

**PANEL OPENING
SECTION A-A**

**VALVE
(ACETAL)**

NOTES:

1. MATERIAL: BRASS
2. FINISH: CHROME
3. O-RING MATERIAL: BUNA-N
4. O-RINGS LUBRICATED WITH FOOD GRADE SILICONE OIL, 350 CST.

FOR REFERENCE ONLY

<small>UNLESS OTHERWISE SPECIFIED: DIMENSIONS ARE IN INCHES TOLERANCES: FRACTIONAL ± 1/32 ANGULAR: MACH ± 0.5 BEND ± 2 ONE PLACE DECIMAL ± 0.1 TWO PLACE DECIMAL ± 0.01 THREE PLACE DECIMAL ± 0.005 TWO PLACE DUAL (mm) [± 0.12]</small>	DRAWN	LMP	3/14/2018	
	CHECKED	HRC	3/14/2018	
	ENG APPR.	HRC	10/18/18	
	MFG APPR.	BDB	10/18/18	
PRODUCTION	LS	10/18/18		PART NO: 40CBV-SB3-05 DESCRIPTION: LinkTech 40CB Series Panel Mt. Female, Valved, 5/16" HB, Chrome Brass
<small>PROPRIETARY AND CONFIDENTIAL THE INFORMATION CONTAINED IN THIS DRAWING IS THE SOLE PROPERTY OF LINKTECH LLC. ANY REPRODUCTION OR DISCLOSURE IN PART OR AS A WHOLE WITHOUT THE WRITTEN PERMISSION OF LINKTECH LLC IS STRICTLY PROHIBITED.</small>				SIZE DWG. NO. REV C 40CB400258 A
SCALE: NTS WEIGHT:			SHEET 1 OF 1	