

REVISIONS						
SHEET	ZONE	REV.	ECO	DESCRIPTION	DATE	APPROVED
1	ALL	A	EPDM O-RING TO PEROXIDE CURE EPDM	9/29/2010	DHL
1	ALL	B	50253	FORMAT UPDATE	3/8/2018	HRC

**PLUG,
(POLYPROPYLENE)**

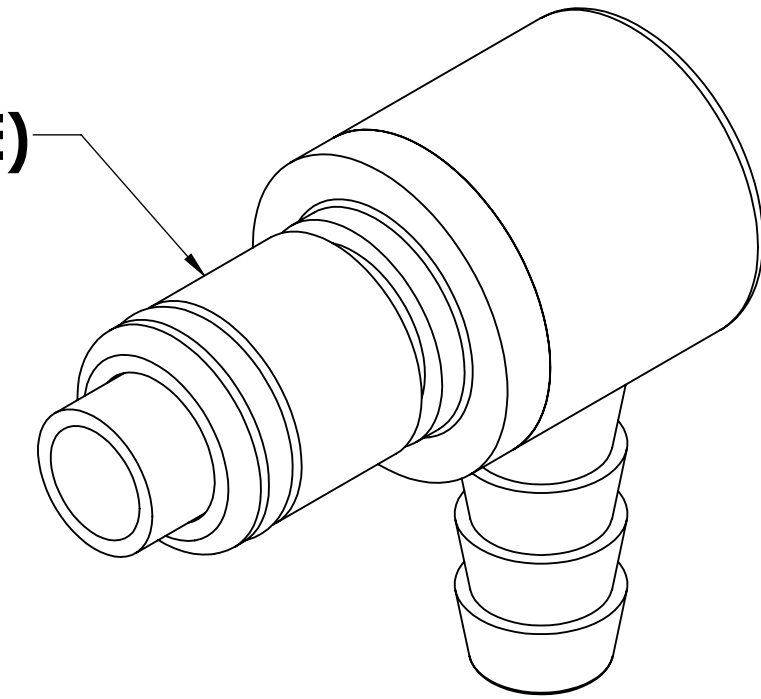

**VALVE,
(POLYPROPYLENE)**

1/4" TUBE ID

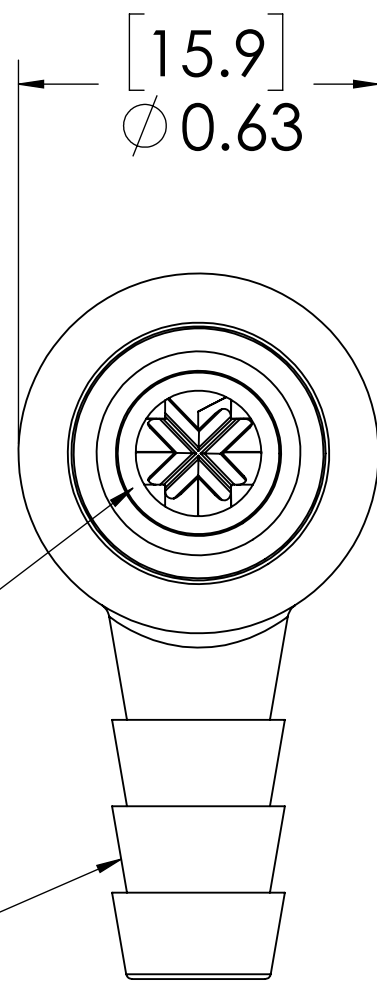

**EXTERNAL O-RING,
(EPDM)**

**VALVE O-RING,
INTERNAL
(EPDM)**

**VALVE SPRING,
INTERNAL
(STAINLESS STEEL)**

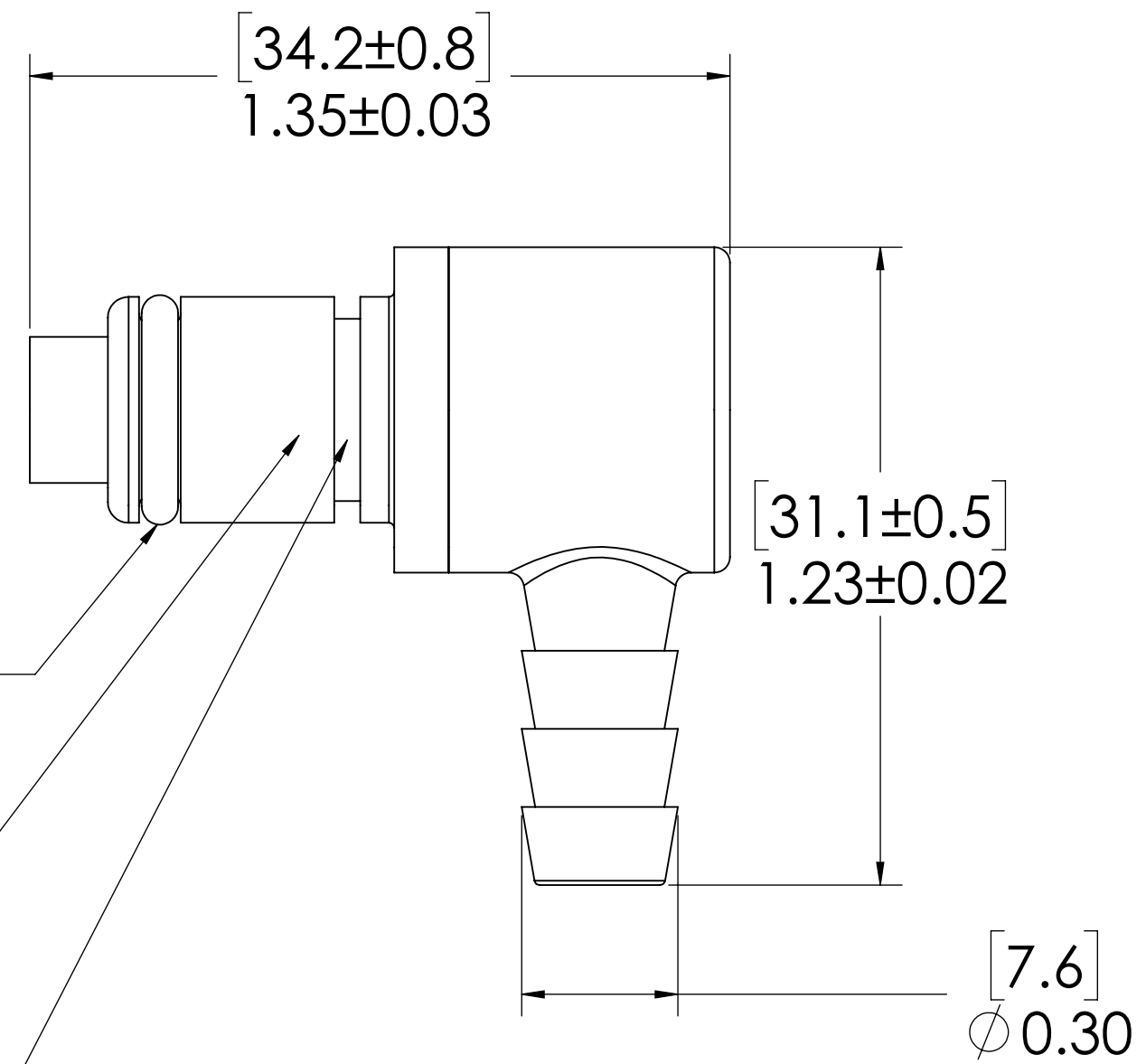

NOTES:

1. MATERIAL: POLYPROPYLENE
2. COLOR: LIGHT GRAY
3. O-RING MATERIAL: EPDM
4. O-RINGS LUBRICATED WITH FOOD GRADE SILICONE OIL, 350 CST.

FOR REFERENCE ONLY

<small>UNLESS OTHERWISE SPECIFIED: DIMENSIONS ARE IN INCHES TOLERANCES: FRACTIONAL ± 1/32 ANGULAR: MACH ± 0.5 BEND ± 2 ONE PLACE DECIMAL ± 0.1 TWO PLACE DECIMAL ± 0.01 THREE PLACE DECIMAL ± 0.005 TWO PLACE DUAL (mm) [±0.12]</small>	DRAWN	RDA	8/24/2017	
	CHECKED	HRC	8/24/2017	
	ENG APPR.	HRC	03-08-18	
	MFG APPR.	BDB	03-08-18	
<small>PROPRIETARY AND CONFIDENTIAL THE INFORMATION CONTAINED IN THIS DRAWING IS THE SOLE PROPERTY OF LINKTECH LLC. ANY REPRODUCTION OR DISCLOSURE IN PART OR AS A WHOLE WITHOUT THE WRITTEN PERMISSION OF LINKTECH LLC IS STRICTLY PROHIBITED.</small>	PURCHASING	RK	03-08-18	PART NO: 40PPV-PE4-04 DESCRIPTION: LinkTech 40PP Series Elbow Male, Valved, 250 HB, Molded Grey Color, Polypropylene <small>SIZE DWG. NO. REV</small> C 40PP400046 B
<small>SCALE: NTS WEIGHT:</small>			<small>SHEET 1 OF 1</small>	