

REVISIONS						
SHEET	ZONE	REV.	ECO	DESCRIPTION	DATE	APPROVED
1	A-1	A	.....	CORRECTED DWG NO.	2/24/2011	DHJ
1	F-8	B	.....	CORRECTED VALVE P/N FROM C11049 TO C11145	5/23/2011	DHJ
1	ALL	C	50253	UPDATE DWG TO CURRENT FORMAT & STANDARDS	10/30/2018	HRC

**LATCH HARDWARE  
(STAINLESS STEEL)**

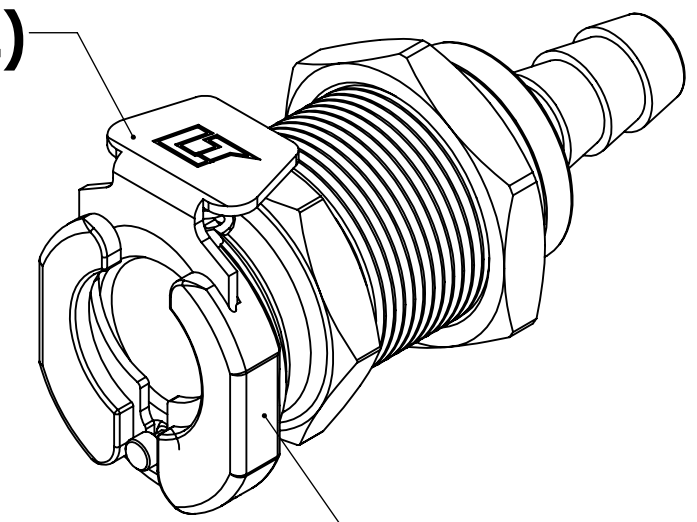

**SOCKET  
(POLYPROPYLENE)**

**VALVE  
(POLYPROPYLENE)**

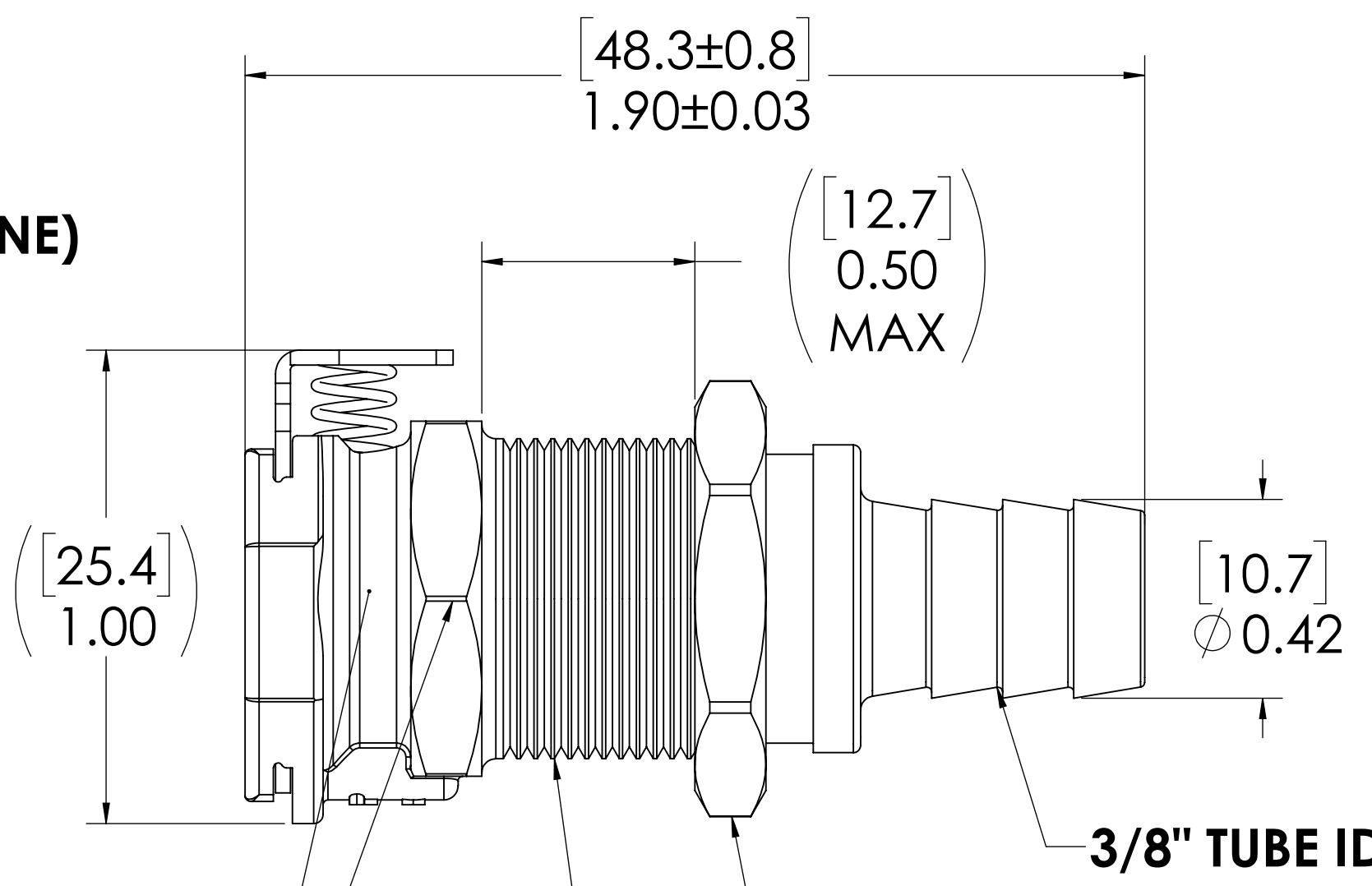
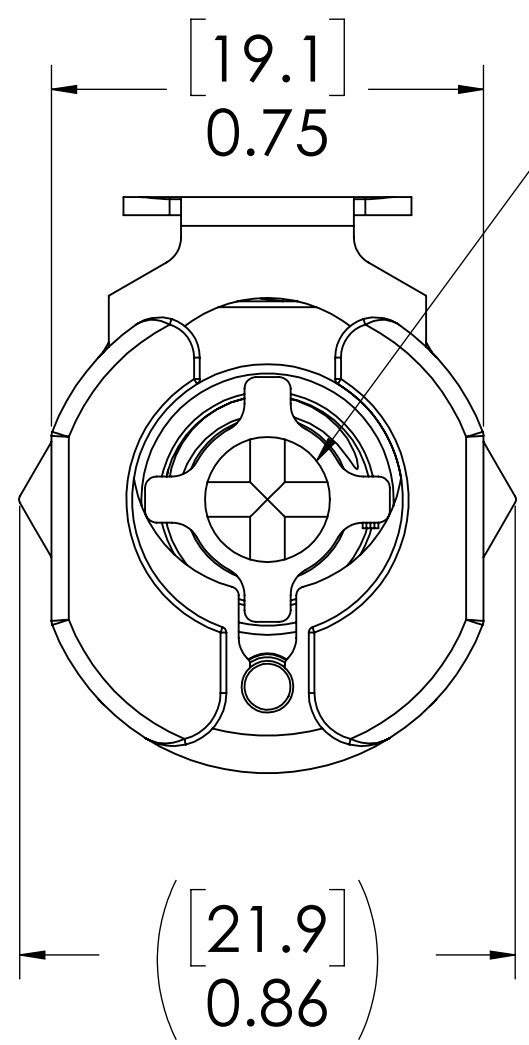

**VALVE O-RING  
INTERNAL  
(EPDM)**  
**VALVE SPRING  
INTERNAL  
(STAINLESS STEEL)**

**PANEL NUT  
(BRASS, NICKEL PLATED)  
(PACKAGED SEPARATELY)**

**11/16\"/>**

**3/8\"/>**

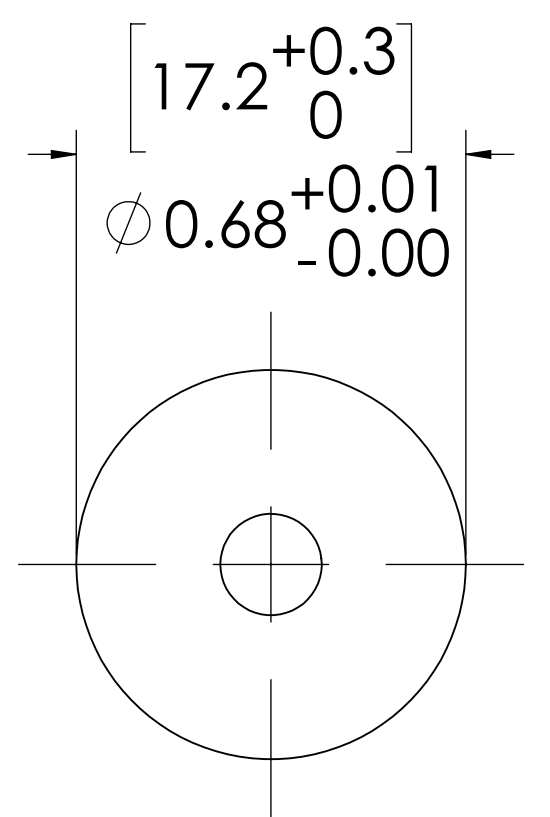

**PANEL OPENING**

- NOTES:**
- MATERIAL: POLYPROPYLENE
  - COLOR: GREY
  - O-RING MATERIAL: EPDM
  - O-RINGS LUBRICATED WITH FOOD GRADE SILICONE OIL, 350 CST.

**FOR REFERENCE ONLY**

<small>UNLESS OTHERWISE SPECIFIED: DIMENSIONS ARE IN INCHES TOLERANCES: FRACTIONAL ± 1/32 ANGULAR: MACH ± 0.5 BEND ± 2 ONE PLACE DECIMAL ± 0.1 TWO PLACE DECIMAL ± 0.01 THREE PLACE DECIMAL ± 0.005 TWO PLACE DUAL (mm) [± 0.12]</small>	DRAWN	LMP	6/12/2018	
	CHECKED	HRC	6/12/2018	
	ENG APPR.	HRC	10/30/18	
	MFG APPR.	BDB	10/30/18	
PRODUCTION	LS	10/30/18		<b>PART NO: 40PPV-SE3-06</b> <b>DESCRIPTION:</b> <b>LinkTech 40PP Series, Panel Mt. Socket, Valved, 3/8" HB, Polypropylene</b>
<small>PROPRIETARY AND CONFIDENTIAL THE INFORMATION CONTAINED IN THIS DRAWING IS THE SOLE PROPERTY OF LINKTECH LLC. ANY REPRODUCTION OR DISCLOSURE IN PART OR AS A WHOLE WITHOUT THE WRITTEN PERMISSION OF LINKTECH LLC IS STRICTLY PROHIBITED.</small>				<b>SIZE DWG. NO. REV</b> <b>C 40PP400065 C</b>
SCALE: NTS			WEIGHT:	SHEET 1 OF 1