

REVISIONS						
SHEET	ZONE	REV.	ECO	DESCRIPTION	DATE	APPROVED
1	C-7	A		CHANGED O-RING FROM FOOD GRADE EPDM TO PEROXIDE CURE EPDM O-RING	9/27/2010	DHJ
1	ALL	B		EDITED PART NUMBER FROM 40PP-PE1-04 TO 40PPX-PE1-04	10/14/2011	HRC
1	ALL	C	50253	UPDATE DWG TO CURRENT FORMAT & STANDARDS	10/23/2018	HRC

**PLUG  
(POLYPROPYLENE)**

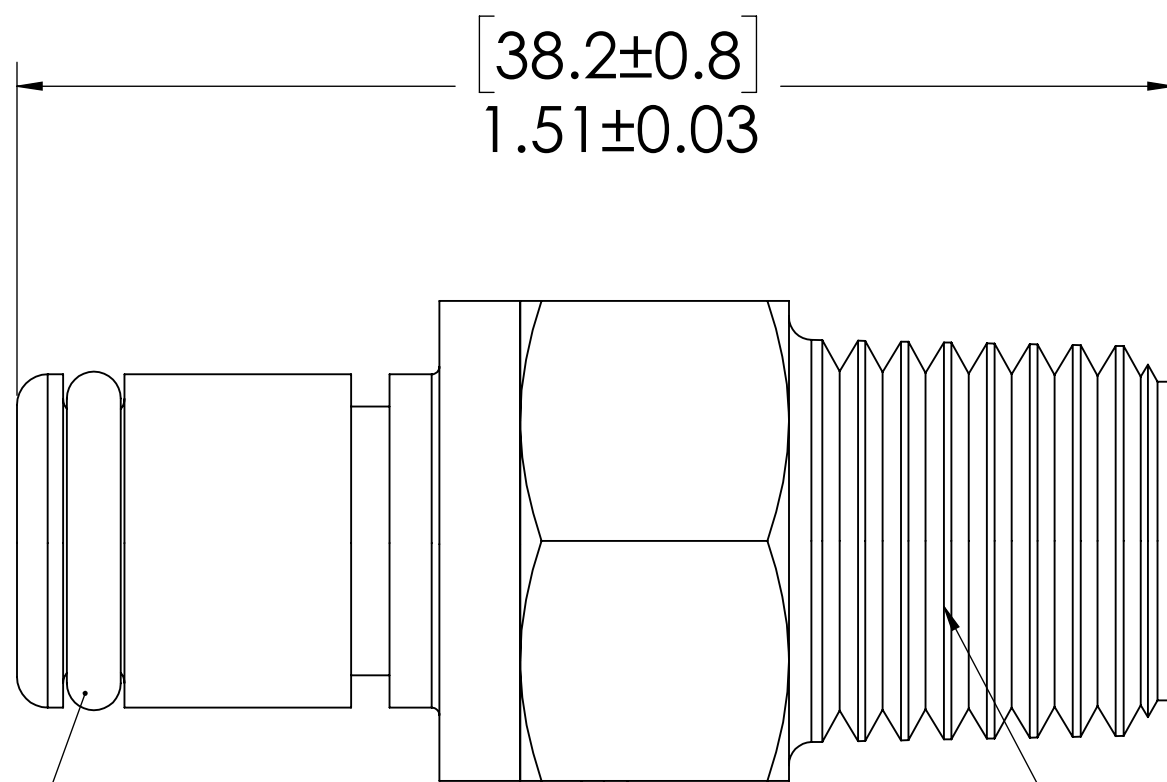
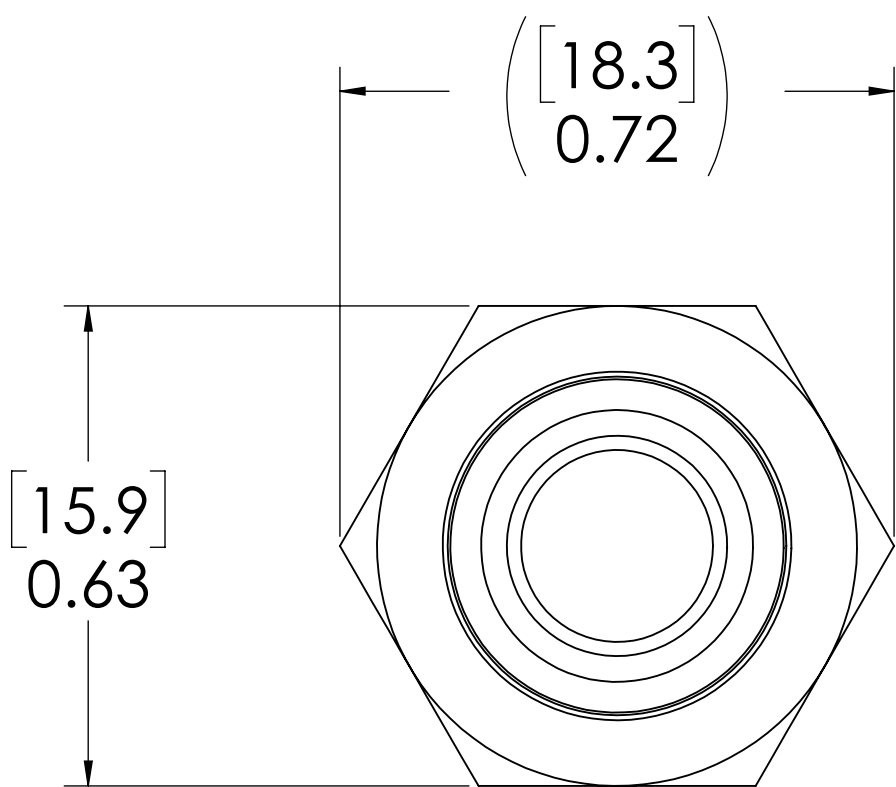
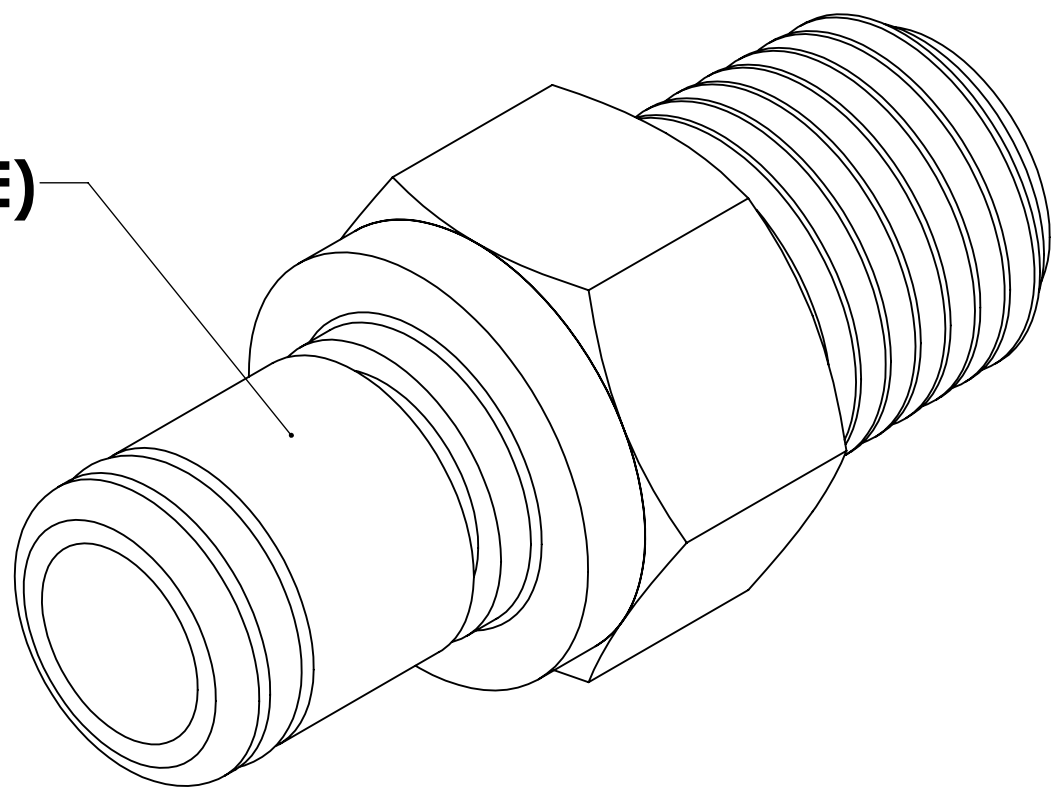

**O-RING  
EXTERNAL  
(EPDM)**

**1/4" NPT  
(PIPE THREAD)**

**NOTES:**

- MATERIAL: POLYPROPYLENE
- COLOR: GRAY
- O-RING MATERIAL: EPDM
- O-RINGS LUBRICATED WITH FOOD GRADE SILICONE OIL, 350 CST.

**FOR REFERENCE ONLY**

<small>UNLESS OTHERWISE SPECIFIED: DIMENSIONS ARE IN INCHES TOLERANCES: FRACTIONAL ± 1/32 ANGULAR, MACH ± 0.5 BEND ± 2 ONE PLACE DECIMAL ± 0.1 TWO PLACE DECIMAL ± 0.01 THREE PLACE DECIMAL ± 0.005 TWO PLACE DUAL (mm) [± 0.12]</small>	<small>DRAWN</small> LMP 3/26/2018	 <small>PART NO:</small> <b>40PPX-PE1-04</b> <small>DESCRIPTION:</small> <b>LinkTech 40PP Series Male Thread Plug, Non-Valved, 1/4" NPT, Polypropylene</b>
	<small>CHECKED</small> HRC 3/26/2018	
	<small>ENG APPR.</small> HRC 10/23/18	
	<small>MFG APPR.</small> BDB 10/23/18	
<small>PRODUCTION</small> LS 10/23/18	<small>COMMENTS:</small>	<small>SIZE</small> <b>C</b>
<small>THE INFORMATION CONTAINED IN THIS DRAWING IS THE SOLE PROPERTY OF LINKTECH LLC. ANY REPRODUCTION OR DISCLOSURE IN PART OR AS A WHOLE WITHOUT THE WRITTEN PERMISSION OF LINKTECH LLC IS STRICTLY PROHIBITED.</small>	<small>DWG. NO.</small> <b>40PP400037</b>	<small>REV</small> <b>C</b>
<small>SCALE: NTS</small>		<small>WEIGHT:</small>
<small>SHEET 1 OF 1</small>		