

REVISIONS						
SHEET	ZONE	REV.	ECO	DESCRIPTION	DATE	APPROVED
1	ALL	NC	50087	DRAWING RELEASED	5/29/14	SCD
1	ALL	A	50253	2017 DWG FORMAT	4/25/2018	HRC

**LATCH HARDWARE,
(STAINLESS STEEL)**

**SOCKET,
(ABS)**

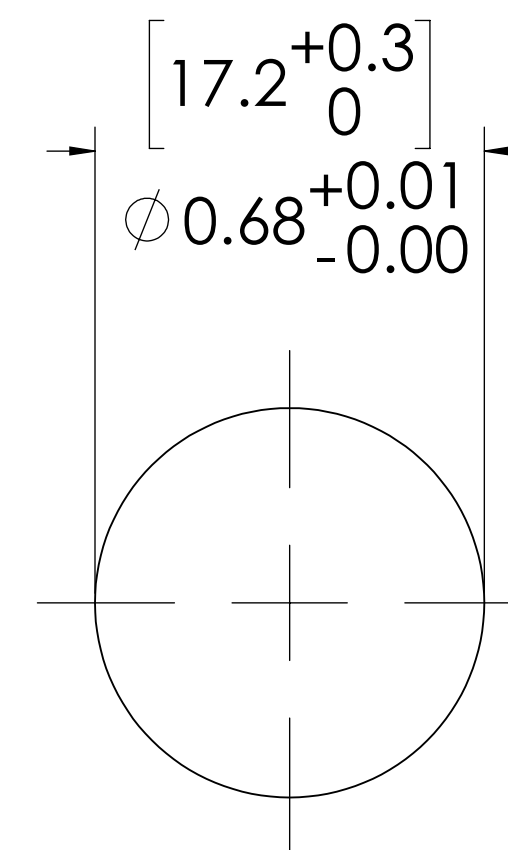
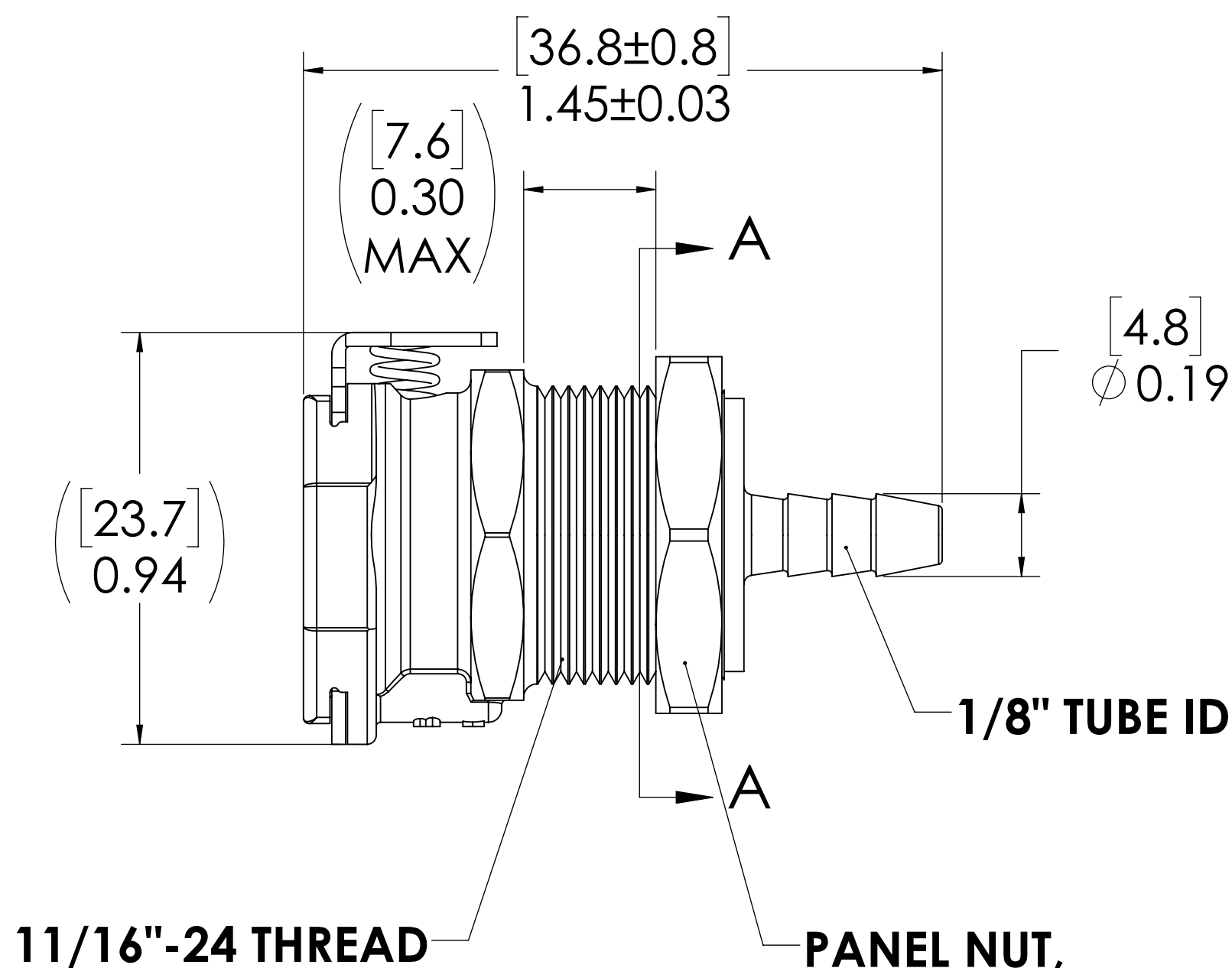
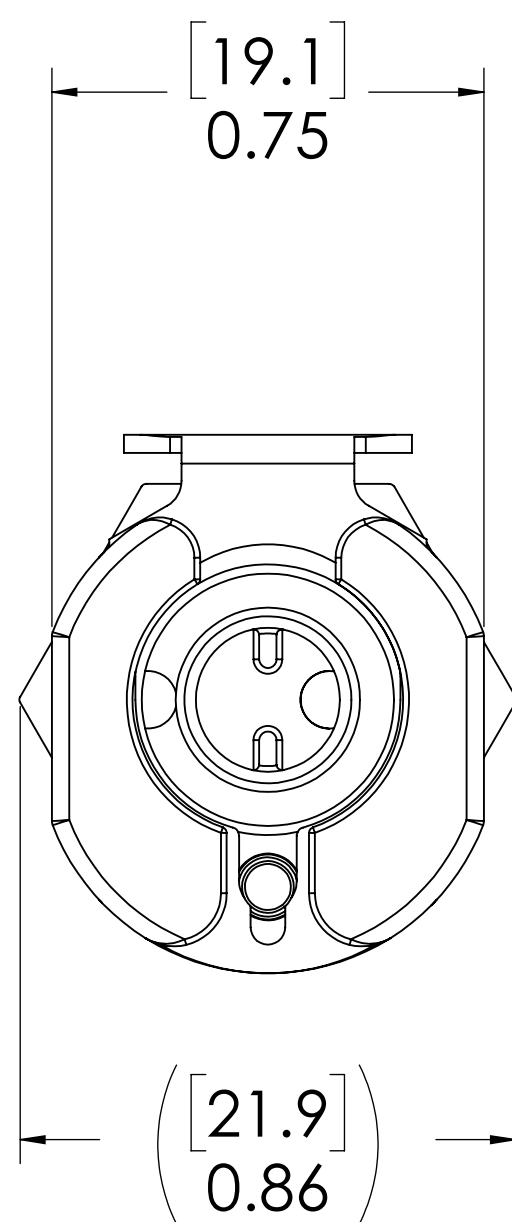
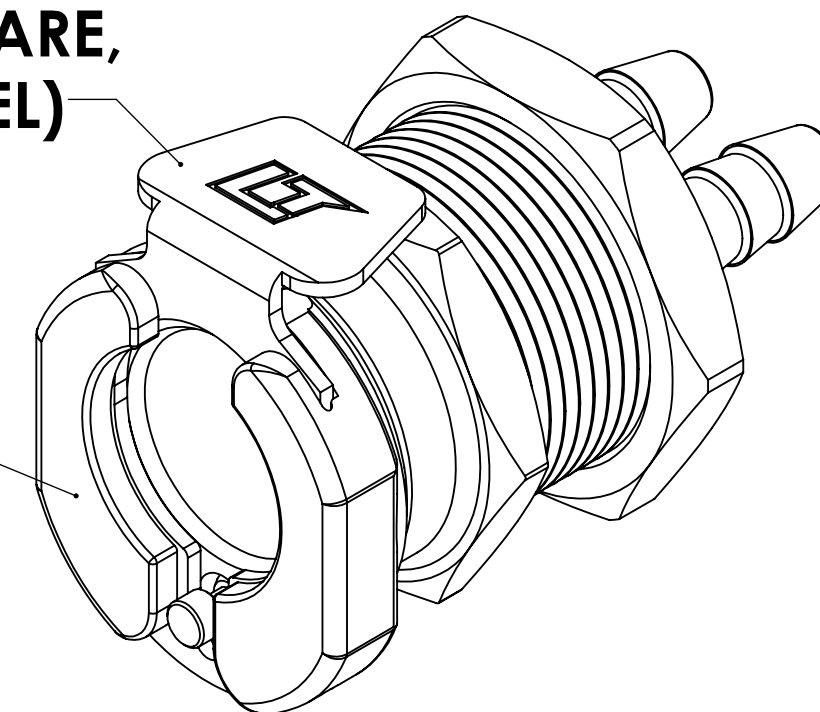

**PANEL OPENING
(SECTION A-A)**

**PANEL NUT,
(BRASS, NICKEL PLATED)
(PACKAGED SEPERATELY)**

FOR REFERENCE ONLY

- NOTES:**
- MATERIAL: ABS
 - COLOR: WHITE

<small>UNLESS OTHERWISE SPECIFIED: DIMENSIONS ARE IN INCHES TOLERANCES: FRACTIONAL ±1/32 ANGULAR, MACH ±0.5 BEND ±2 ONE PLACE DECIMAL ±0.1 TWO PLACE DECIMAL ±0.01 THREE PLACE DECIMAL ±0.005 TWO PLACE DUAL (mm) [±0.12]</small>	DRAWN	SCD	12/20/13	
	CHECKED	HRC	12/20/13	
	ENG APPR.	HRC	4/25/18	
	MFG APPR.	BDB	4/25/18	
<small>PROPRIETARY AND CONFIDENTIAL THE INFORMATION CONTAINED IN THIS DRAWING IS THE SOLE PROPERTY OF LINKTECH LLC. ANY REPRODUCTION OR DISCLOSURE IN PART OR AS A WHOLE WITHOUT THE WRITTEN PERMISSION OF LINKTECH LLC IS STRICTLY PROHIBITED.</small>	Q.A.	RK	4/25/18	PART NO: 42AB-S3-02 DESCRIPTION: LinkTech 42AB Series Panel Mt. Male, Non-valved, 1/8"HB, ABS
	COMMENTS:			SIZE DWG. NO. C 42AB400026 REV A
				SCALE: NTS WEIGHT: SHEET 1 OF 1