

REVISIONS						
SHEET	ZONE	REV.	ECO	DESCRIPTION	DATE	APPROVED
1	ALL	NC	50093	INITIAL RELEASE	9/10/2014	HRC
1	ALL	A	50257	O-RING AND DWG FORMAT UPDATE	3/5/2018	HRC

PLUG,
(POLYPROPYLENE)

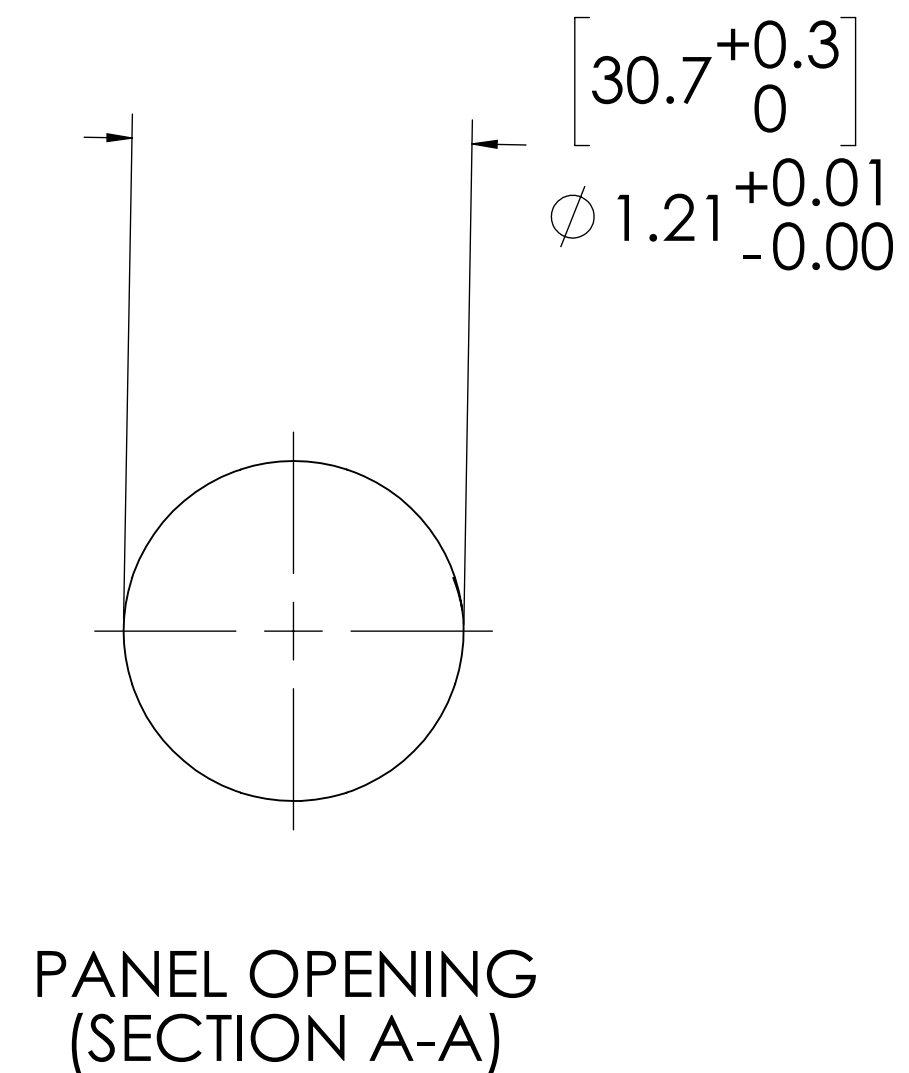
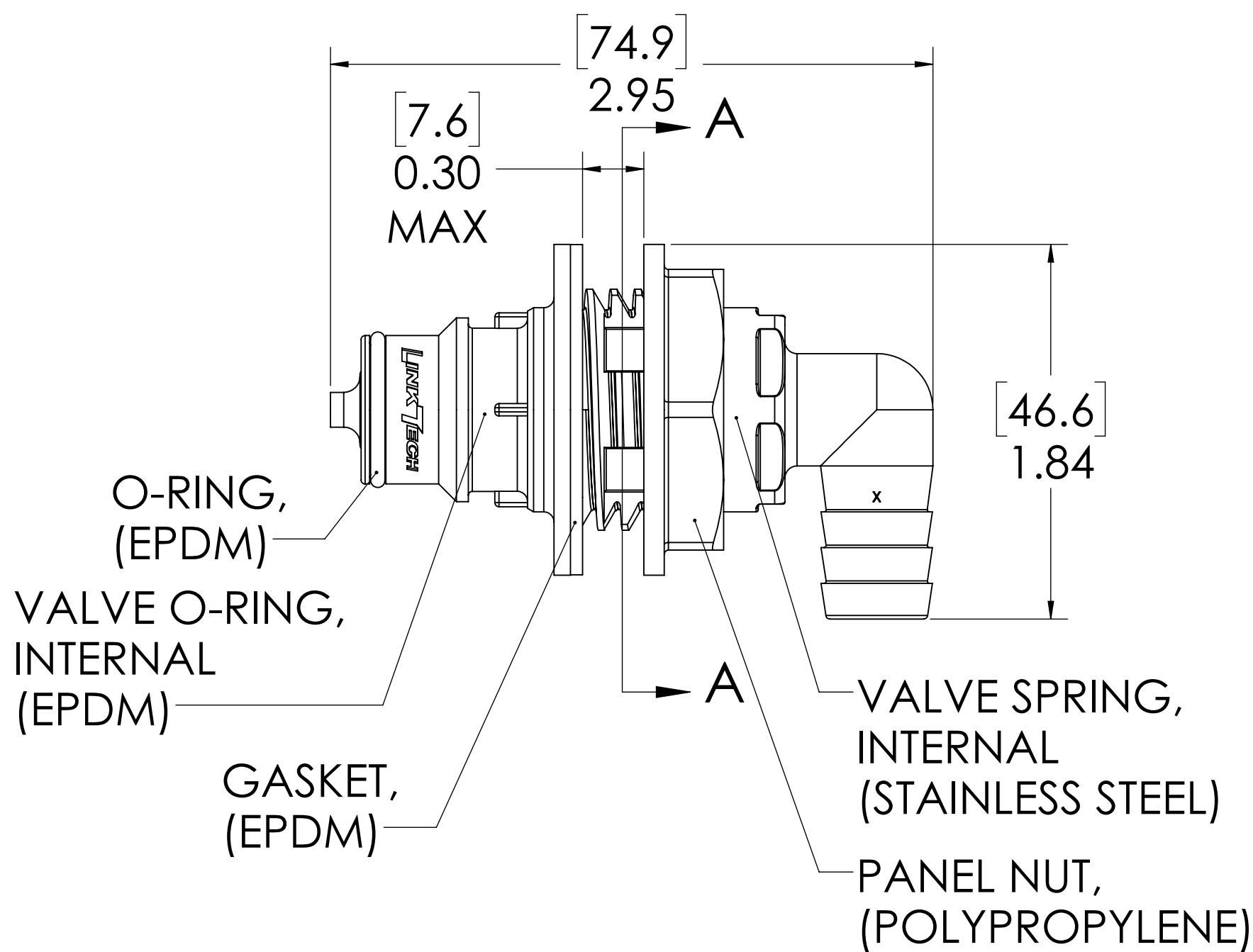
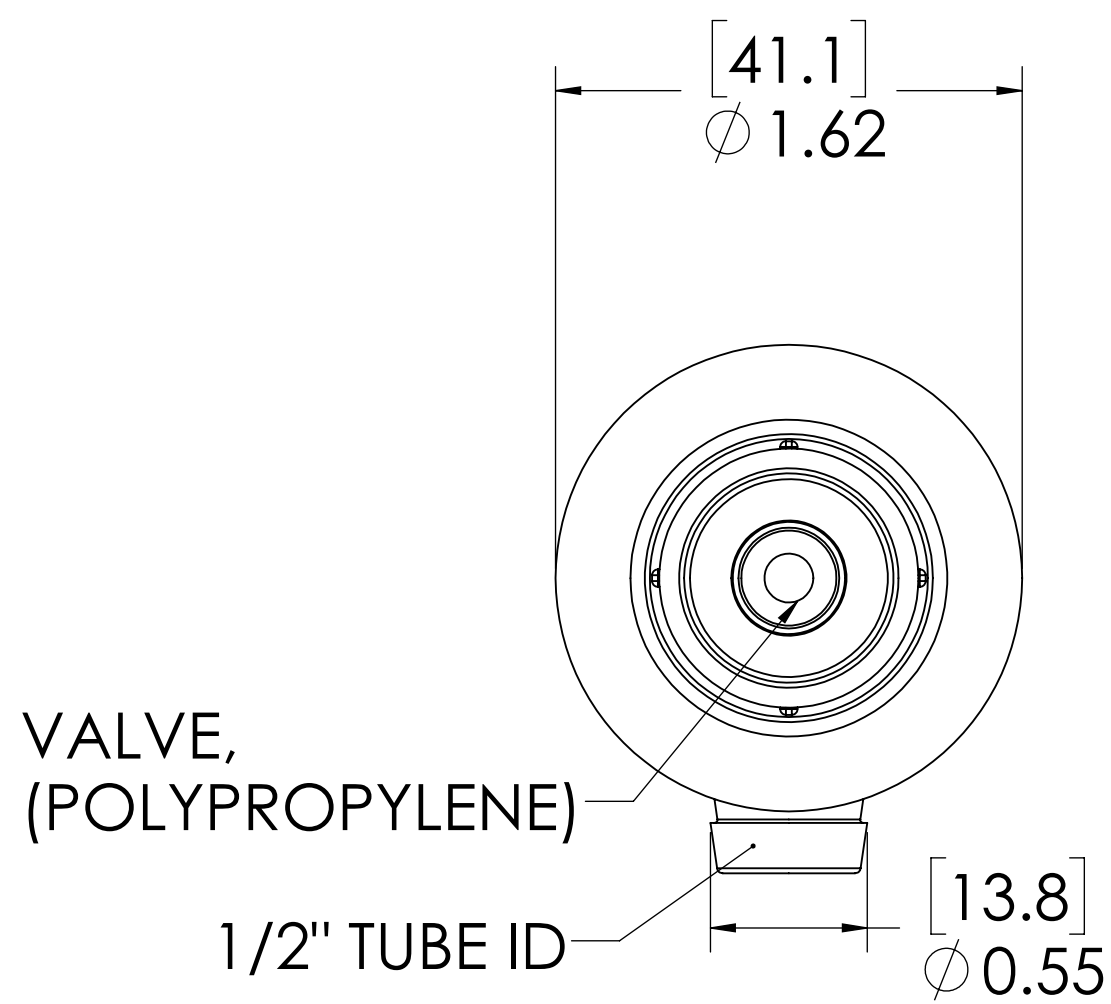
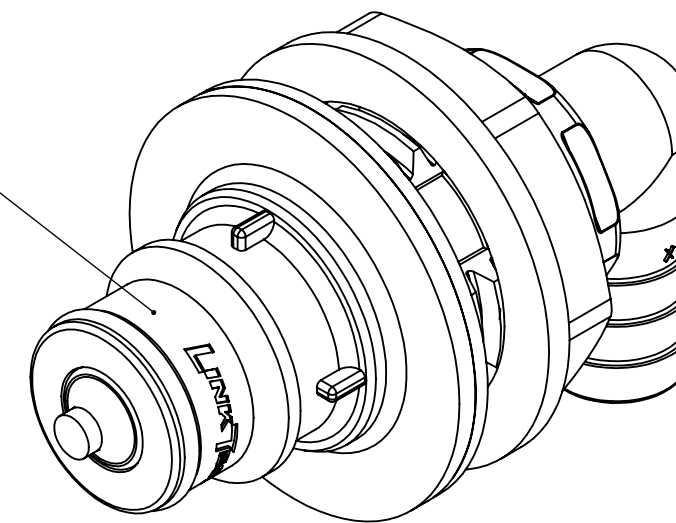

NOTES:

- MATERIAL: POLYPROPYLENE
- COLOR: GREY
- O-RING MATERIAL: EPDM
- O-RINGS LUBRICATED WITH FOOD GRADE SILICONE OIL, 350 CST.

FOR REFERENCE ONLY

<small>UNLESS OTHERWISE SPECIFIED: DIMENSIONS ARE IN INCHES TOLERANCES: FRACTIONAL ± 1/32 ANGULAR: MACH ± 0.5 BEND ± 2 ONE PLACE DECIMAL ± 0.1 TWO PLACE DECIMAL ± 0.01 THREE PLACE DECIMAL ± 0.005 TWO PLACE DUAL (mm) [± 0.12]</small>	DRAWN	HRC	6/23/14	
	CHECKED	HRC	6/23/14	
	ENG APPR.	HRC	3/5/2018	
	MFG APPR.	BDB	3/5/2018	
PROPRIETARY AND CONFIDENTIAL	Q.A.	JJB	3/5/2018	PART NO: 60PPV-PE22-08 DESCRIPTION: LinkTech 60PP Series Panel Mt. Male, Valved 1/2" HB Elbow, Polypropylene
<small>THE INFORMATION CONTAINED IN THIS DRAWING IS THE SOLE PROPERTY OF LINKTECH LLC. ANY REPRODUCTION OR DISCLOSURE IN PART OR AS A WHOLE WITHOUT THE WRITTEN PERMISSION OF LINKTECH LLC IS STRICTLY PROHIBITED.</small>			COMMENTS:	
<small>SCALE: NTS</small>	<small>WEIGHT:</small>	<small>SHEET 1 OF 1</small>		