

REVISIONS						
SHEET	ZONE	REV.	ECO	DESCRIPTION	DATE	APPROVED
1	ALL	NC	50108	INITIAL RELEASE	9/9/2014	HRC
1	ALL	A	50257	O-RING AND DWG FORMAT UPDATE	6/28/2018	HRC

PLUG,
(POLYSULFONE)

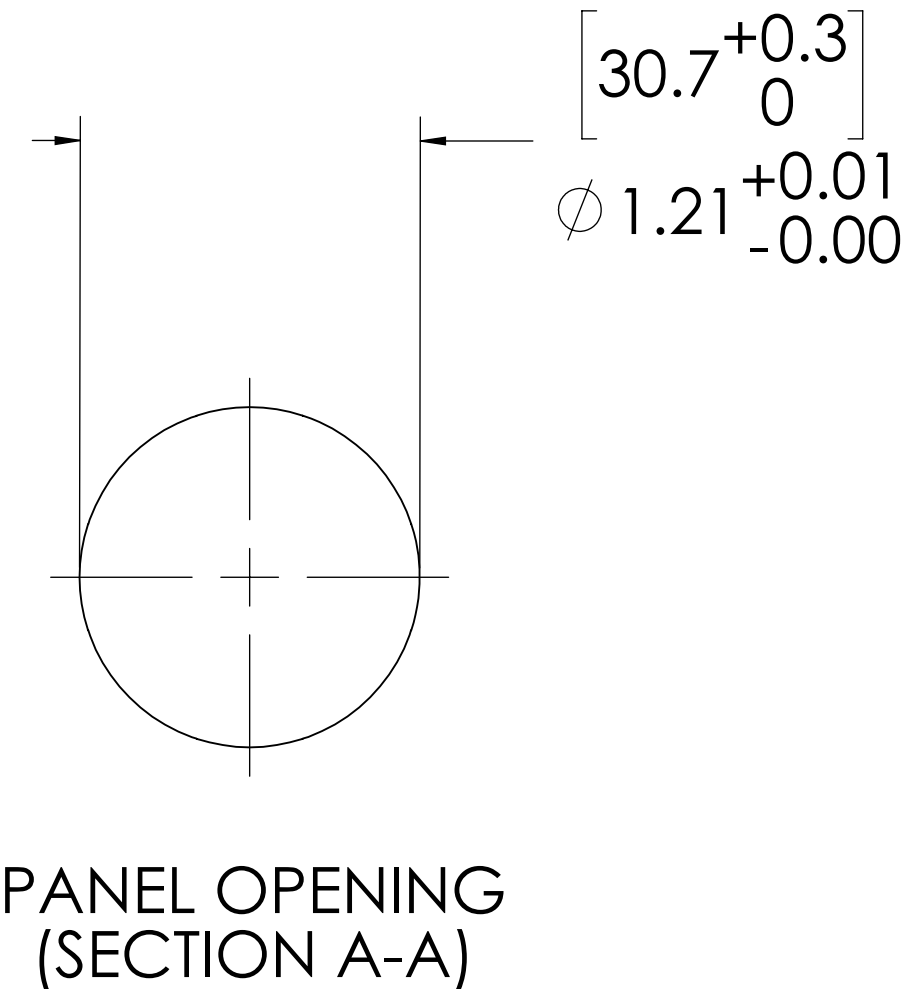
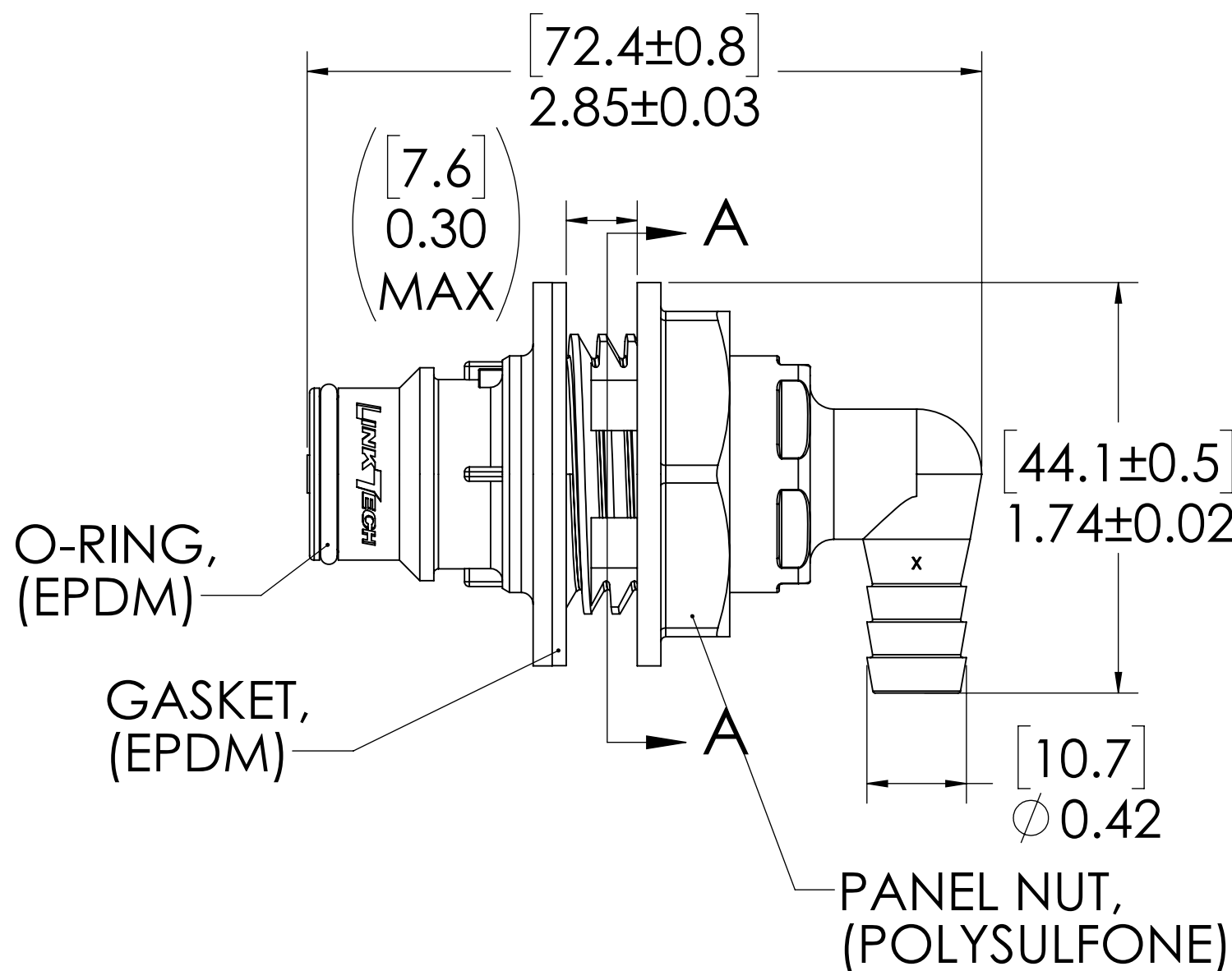
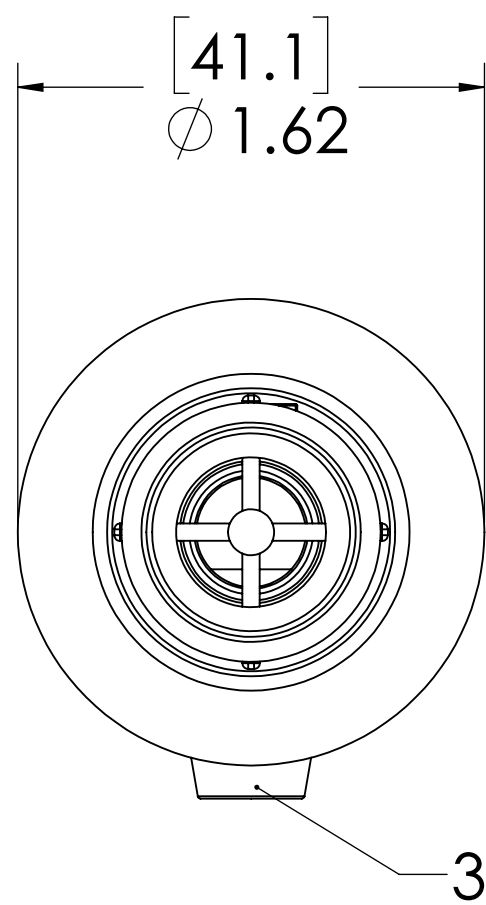
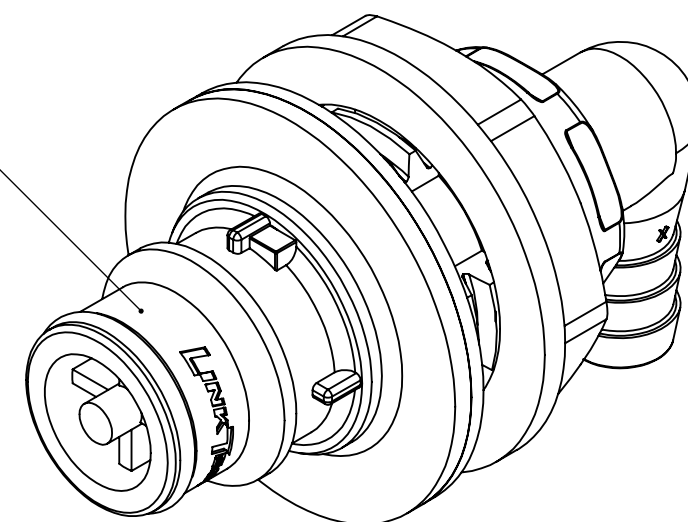

NOTES:

1. MATERIAL: POLYSULFONE
2. COLOR: WHITE
3. O-RING MATERIAL: EPDM
4. O-RINGS LUBRICATED WITH FOOD GRADE SILICONE OIL, 350 CST.

FOR REFERENCE ONLY

<small>UNLESS OTHERWISE SPECIFIED: DIMENSIONS ARE IN INCHES TOLERANCES: FRACTIONAL ± 1/32 ANGULAR: MACH ± 0.5 BEND ± 2 ONE PLACE DECIMAL ± 0.1 TWO PLACE DECIMAL ± 0.01 THREE PLACE DECIMAL ± 0.005 TWO PLACE DUAL (mm) [± 0.12]</small>	DRAWN	HRC	9/9/2014	
	CHECKED	HRC	9/9/2014	
	ENG APPR.	HRC	6/28/18	
	MFG APPR.	BDB	6/28/18	
PRODUCTION	LS	6/28/18		PART NO: 60PS-PE22-06 DESCRIPTION: LinkTech 60PS Series Panel Mt. Male, Non-valved 3/8" HB Elbow, Polysulfone
<small>PROPRIETARY AND CONFIDENTIAL THE INFORMATION CONTAINED IN THIS DRAWING IS THE SOLE PROPERTY OF LINKTECH LLC. ANY REPRODUCTION OR DISCLOSURE IN PART OR AS A WHOLE WITHOUT THE WRITTEN PERMISSION OF LINKTECH LLC IS STRICTLY PROHIBITED.</small>	COMMENTS:			SIZE DWG. NO. REV C 60PS600085 A
				SCALE: NTS WEIGHT: SHEET 1 OF 1