

REVISIONS						
SHEET	ZONE	REV.	ECO	DESCRIPTION	DATE	APPROVED
1	D-6	A	.....	UPDATED LATCH SPRING	8/20/2014	HRC
1	ALL	A	50108	INITIAL RELEASE	9/9/2014	HRC
1	ALL	B	50311	UPDATE DWG TO CURRENT FORMAT & STANDARDS	1/17/2020	CKE

**LATCH  
(POLYSULFONE)**

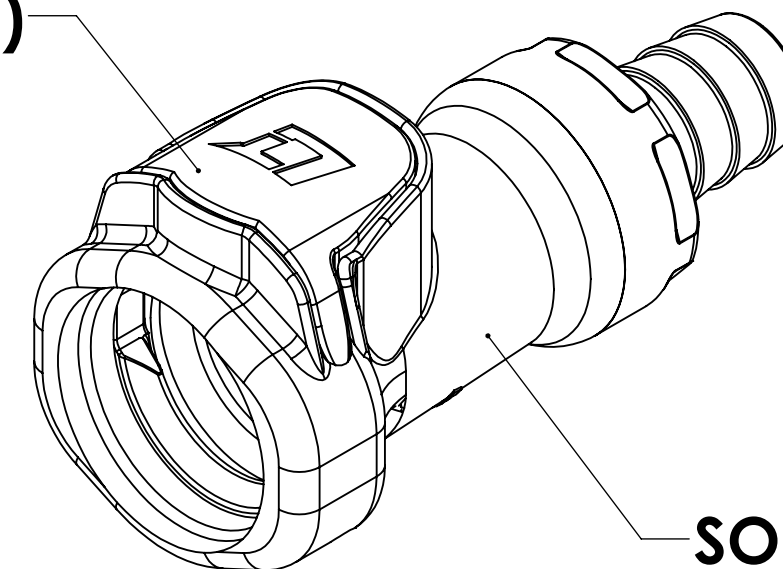

**SOCKET  
(POLYSULFONE)**

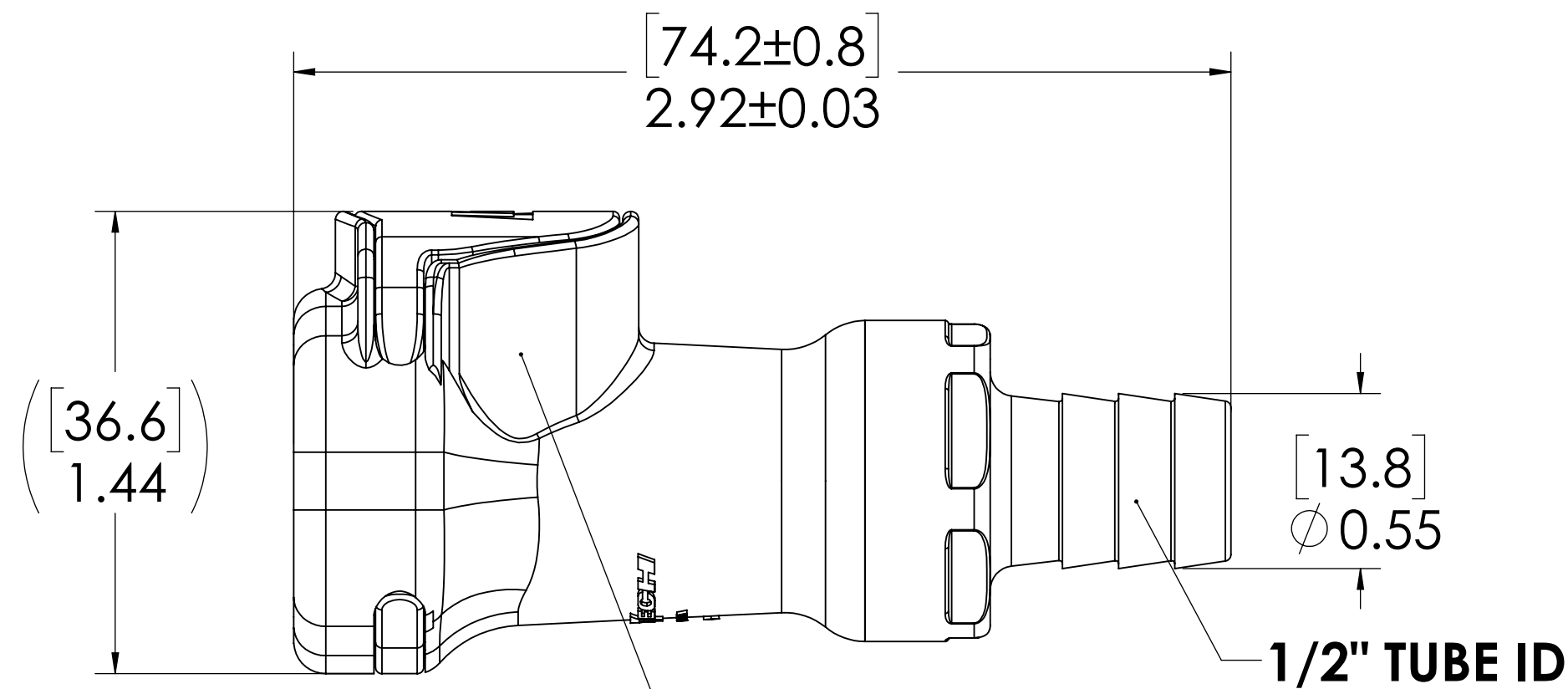
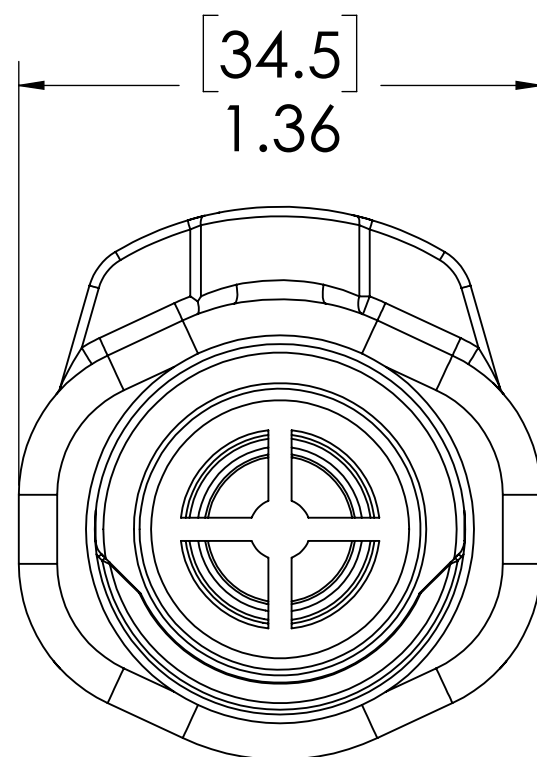

**LATCH SPRING  
INTERNAL  
(STAINLESS STEEL)**

- NOTES:**
1. MATERIAL: POLYSULFONE
  2. COLOR: WHITE/GREY

**FOR REFERENCE ONLY**

<small>UNLESS OTHERWISE SPECIFIED: DIMENSIONS ARE IN INCHES TOLERANCES: FRACTIONAL ± 1/32 ANGULAR: MACH ± 0.5 BEND ± 2 ONE PLACE DECIMAL ± 0.1 TWO PLACE DECIMAL ± 0.01 THREE PLACE DECIMAL ± 0.005 TWO PLACE DUAL (mm) [±0.12]</small>	<small>DRAWN</small> HRC 09-04-13	 <b>PART NO: 60PS-S2-08</b>
	<small>CHECKED</small> CKE 1/9/2020	
	<small>ENG APPR.</small> HRC 1/17/20	
	<small>MFG APPR.</small> BDB 1/17/20	
<small>PRODUCTION</small> LS 1/17/20	<small>DESCRIPTION:</small> <b>LinkTech 60PS Series, Inline Socket, Non-Valved, 1/2" HB</b>	
<small>PROPRIETARY AND CONFIDENTIAL</small> <small>THE INFORMATION CONTAINED IN THIS DRAWING IS THE SOLE PROPERTY OF LINKTECH LLC. ANY REPRODUCTION OR DISCLOSURE IN PART OR AS A WHOLE WITHOUT THE WRITTEN PERMISSION OF LINKTECH LLC IS STRICTLY PROHIBITED.</small>	<small>COMMENTS:</small>	<small>SIZE</small> C <small>DWG. NO.</small> 60PS600054 <small>REV</small> B
<small>SCALE: NTS</small>   <small>WEIGHT:</small>   <small>SHEET 1 OF 1</small>		