

REVISIONS						
SHEET	ZONE	REV.	ECO	DESCRIPTION	DATE	APPROVED
1	ALL	NC	50108	INITIAL RELEASE	9/9/2014	HRC
1	ALL	A	50257	O-RING AND DWG FORMAT UPDATE	7/9/2018	HRC

PLUG,  
(POLYSULFONE)

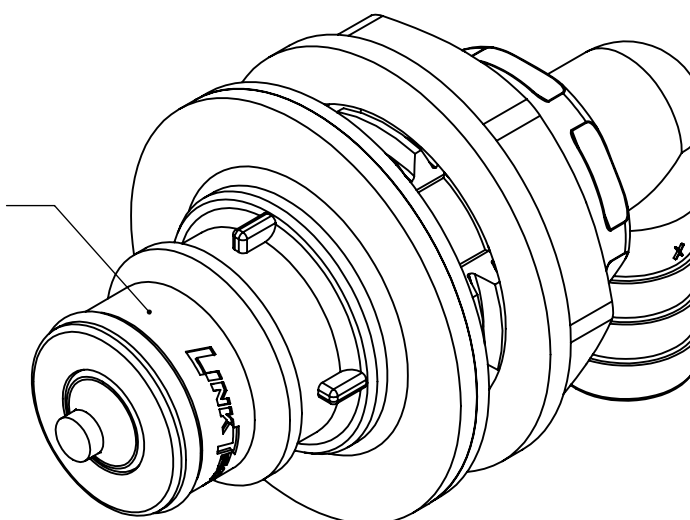

VALVE,  
(POLYSULFONE)

1/2" TUBE ID

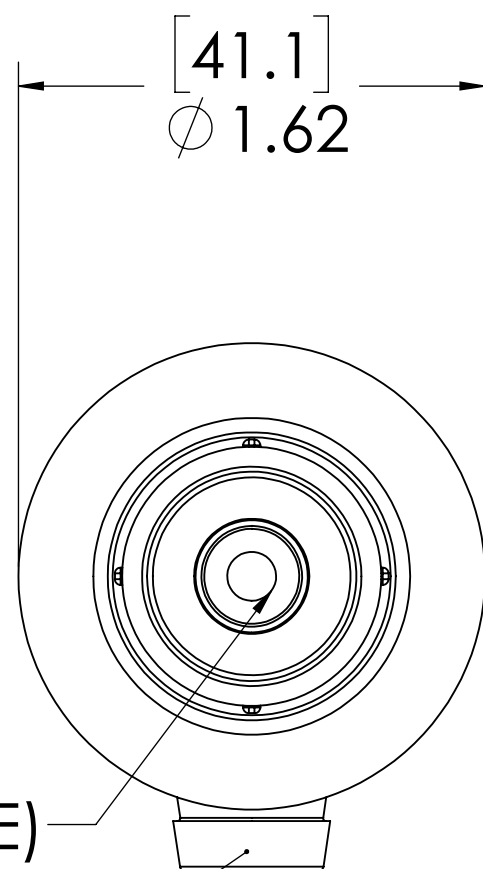

O-RING,  
(EPDM)

VALVE O-RING,  
INTERNAL  
(EPDM)

GASKET,  
(EPDM)

VALVE SPRING,  
INTERNAL  
(STAINLESS STEEL)

PANEL NUT,  
(POLYSULFONE)

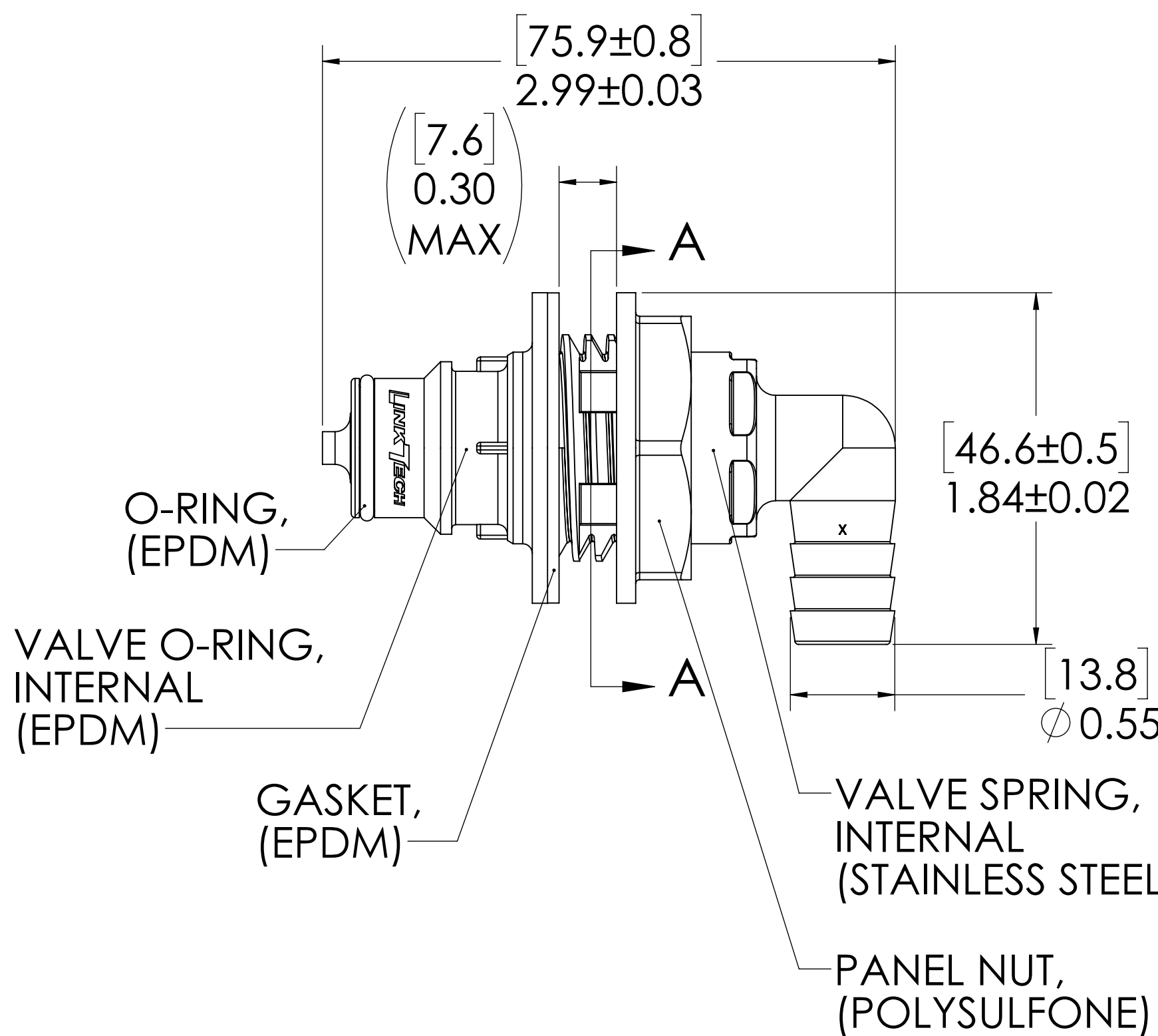

PANEL OPENING  
(SECTION A-A)

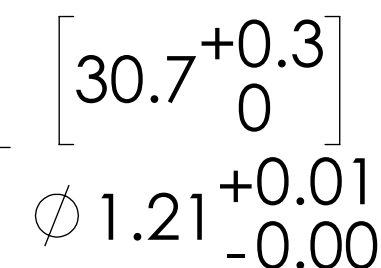

**NOTES:**

- MATERIAL: POLYSULFONE
- COLOR: WHITE
- O-RING MATERIAL: EPDM
- O-RINGS LUBRICATED WITH FOOD GRADE SILICONE OIL, 350 CST.

**FOR REFERENCE ONLY**

<small>UNLESS OTHERWISE SPECIFIED: DIMENSIONS ARE IN INCHES TOLERANCES: FRACTIONAL ± 1/32 ANGULAR: MACH ± 0.5 BEND ± 2 ONE PLACE DECIMAL ± 0.1 TWO PLACE DECIMAL ± 0.01 THREE PLACE DECIMAL ± 0.005 TWO PLACE DECIMAL (mm) [± 0.12]</small>	DRAWN	HRC	8/21/14	
	CHECKED	HRC	8/21/14	
	ENG APPR.	HRC	7/9/18	
	MFG APPR.	BDB	7/9/18	
PRODUCTION	LS	7/9/18		<b>PART NO:</b> 60PSV-PE22-08 <b>DESCRIPTION:</b> LinkTech 60PS Series Panel Mt. Male, Valved 1/2" HB Elbow, Polysulfone
<small>THE INFORMATION CONTAINED IN THIS DRAWING IS THE SOLE PROPERTY OF LINKTECH LLC. ANY REPRODUCTION OR DISCLOSURE IN PART OR AS A WHOLE WITHOUT THE WRITTEN PERMISSION OF LINKTECH LLC IS STRICTLY PROHIBITED.</small>	COMMENTS:			<b>SIZE</b> DWG. NO. REV <b>C</b> 60PS600090 <b>A</b>
SCALE: NTS		WEIGHT:	SHEET 1 OF 1	