

NOTE: FOR MORE DETAILS SEE YOUR V.P. CUSTOMER SERVICE REP.

REVISIONS			
REV.	DESCRIPTION	DATE	APPROVED
A	INITIAL RELEASE	04-30-02	
B	CO 046 Drafting Update	6-20-06	Rick C.

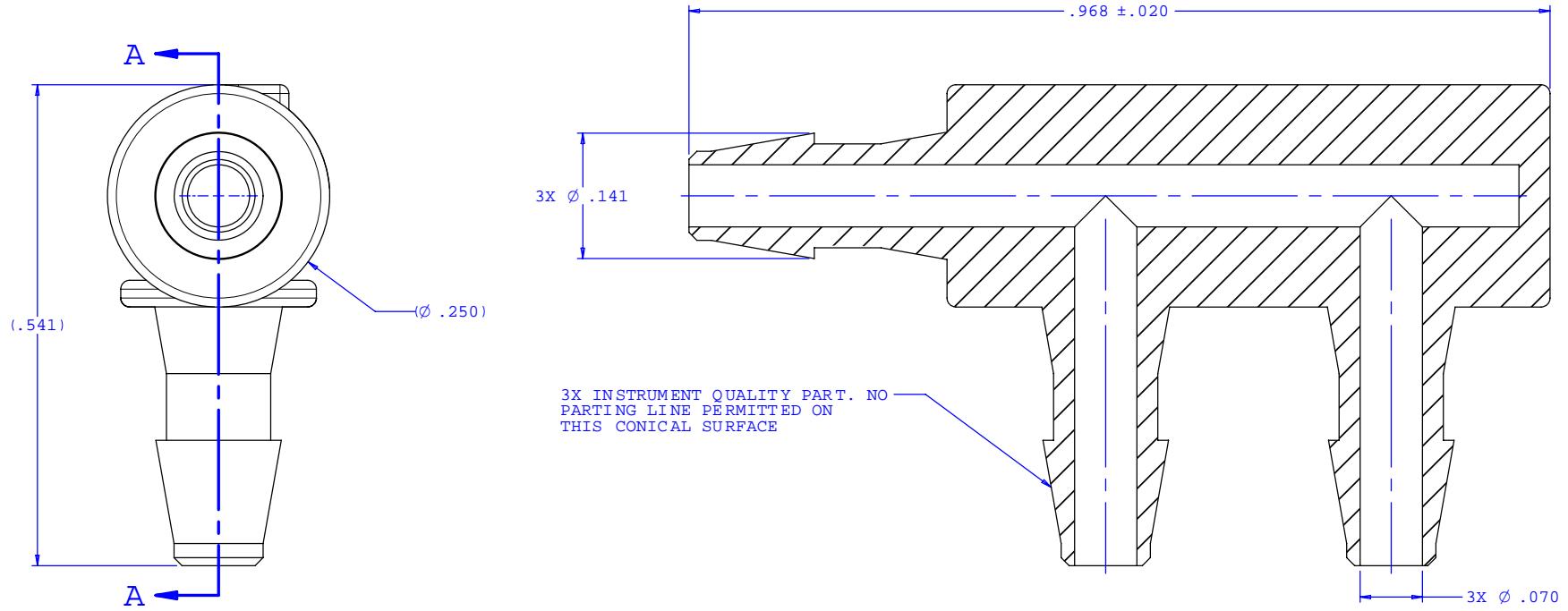

SECTION A-A

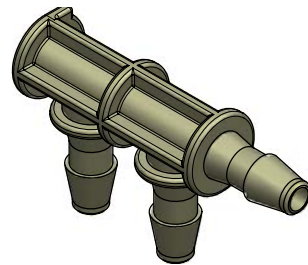

UNLESS OTHERWISE SPECIFIED DIMENSIONS ARE IN INCHES TOLERANCES ARE:		VALUE PLASTICS, INC.	
FRACTIONS ±	DECIMALS .XX ±.01 .XXX ±.005 .XXXX ±.001	ANGULAR ±1°	PART NUMBER: 3PF220
DO NOT SCALE DRAWING		DESCRIPTION: Three-port F Style Manifold with 200 Series Barbs for 3/32" (2.25 mm) ID Tubing	
DRAWN BY: Frank Lombardi	DATE: 05-01-06	SIZE: B	SCALE: NTS
Engineer/Manager: Rick Cairns		DRAWING NUMBER: 1008704	REV. B
© 2006 VALUE PLASTICS, INC.			SHEET: 1 OF 1

FOR REFERENCE ONLY