

NOTE: FOR MORE DETAILS SEE YOUR V.P.CUSTOMER SERVICE REP.

REVISIONS			
REV.	DESCRIPTION	DATE	APPROVED
A	ECO-0009	07-22-99	
B	CO 015 Drafting Update	05-16-05	Rick C.

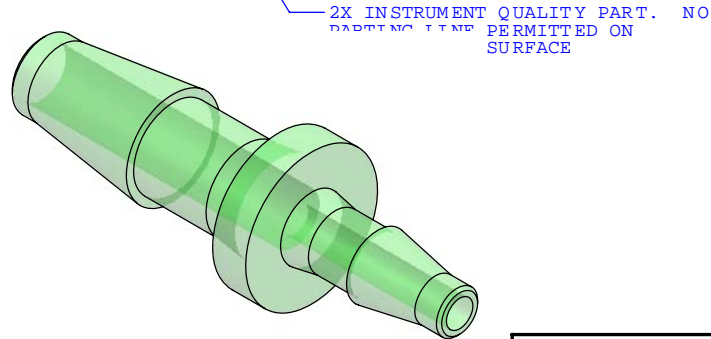
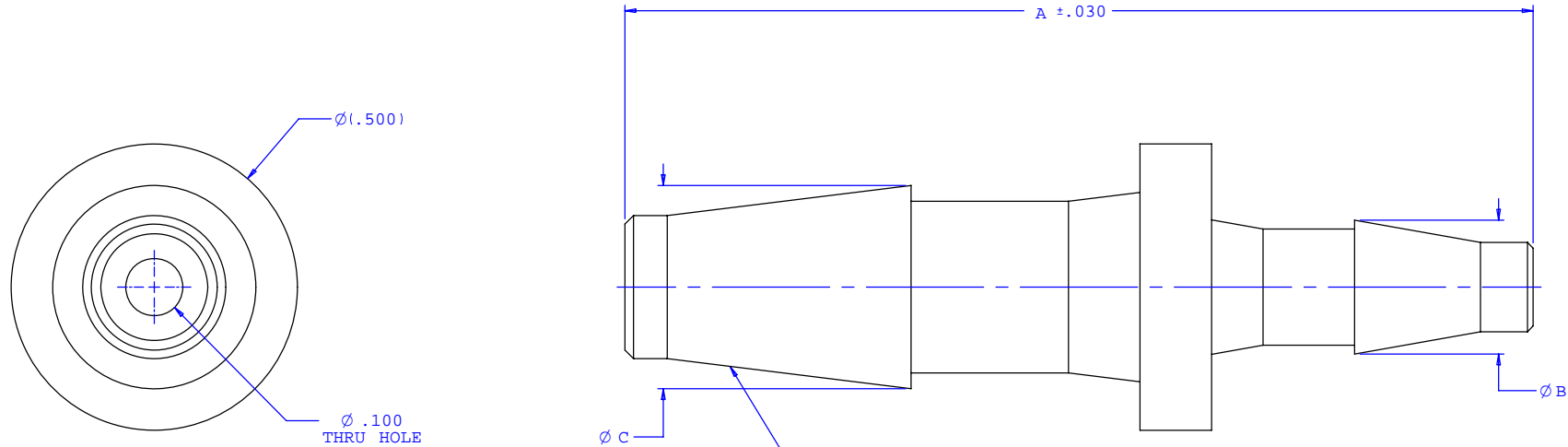

2X INSTRUMENT QUALITY PART. NO DRAFTING TYPING PERMITTED ON SURFACE

Dimension	Material Specific Tolerances							
	Acetal	Nylon	PP	ABS	PC	PVC	Polysulfone	J1A
A	1.587	1.587	1.587	1.587	1.587	1.587	1.587	1.554
B	.234	.234	.229	.234	.234	.234	.234	.226
C	.355	.355	.355	.355	.355	.355	.355	.351
D								
E								
F								

UNLESS OTHERWISE SPECIFIED DIMENSIONS ARE IN INCHES TOLERANCES ARE:		VALUE PLASTICS, INC.	
FRACTIONS ±	DECIMALS .XX ±.01 .XXX ±.005 .XXXX ±.001	ANGULAR ±1°	PART NUMBER: 4060
DO NOT SCALE DRAWING		DESCRIPTION: Straight Through Reduction Connector with Classic Series Barbs, 1/4" (6.25 mm) and 5/32" (4 mm) ID Tubing	
DRAWN BY: Frank Lombardi 4-18-05	DATE:	SIZE: B	SCALE: NTS
Engineer/Manager: Rick Cairns		DRAWING NUMBER: 1006340	REV. B
© 2005 VALUE PLASTICS, INC.		SHEET: 1 OF 1	

FOR REFERENCE ONLY