

NOTE: FOR MORE DETAILS SEE YOUR V.P. CUSTOMER SERVICE REP.

REVISIONS			
REV.	DESCRIPTION	DATE	APPROVED
A	INITIAL RELEASE	04-30-02	
B	CO 046 Drafting Update	6-20-06	Rick C.

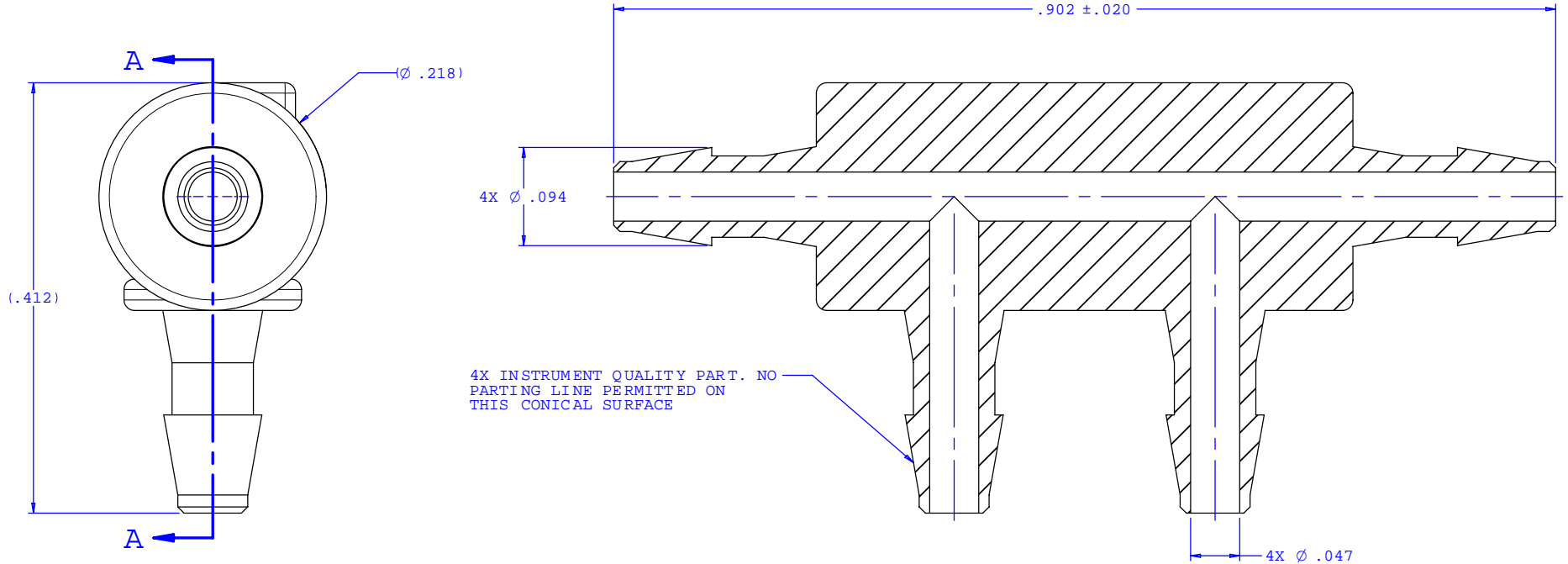

SECTION A-A

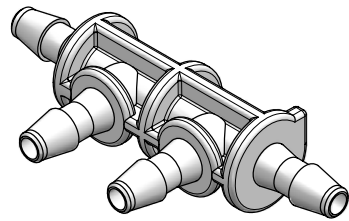

UNLESS OTHERWISE SPECIFIED DIMENSIONS ARE IN INCHES TOLERANCES ARE:		VALUE PLASTICS, INC.	
FRACTIONS ±	DECIMALS .XX ±.01 .XXX ±.005 .XXXX ±.001	ANGULAR ±1°	PART NUMBER: 4PLL210
DO NOT SCALE DRAWING		DESCRIPTION: Four-port Thru Flow Double Elbow Style Manifold with 200 Series Barbs for 1/16" (1.5 mm) ID Tubing	
DRAWN BY: Frank Lombardi	DATE: 05-01-06	SIZE: B SCALE: NTS	DRAWING NUMBER: 1008700 REV. B
Engineer/Manager: Rick Cairns		© 2006 VALUE PLASTICS, INC. SHEET: 1 OF 1	

FOR REFERENCE ONLY