

NOTE: FOR MORE DETAILS SEE YOUR V.P. CUSTOMER SERVICE REP.

REVISIONS			
REV.	DESCRIPTION	DATE	APPROVED
A	ECO# 0036	04-02-01	
B	CO 027 Drafting Update	10-04-05	Rick C.

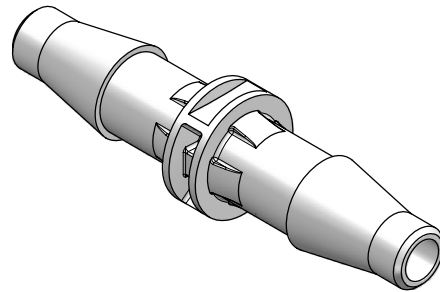
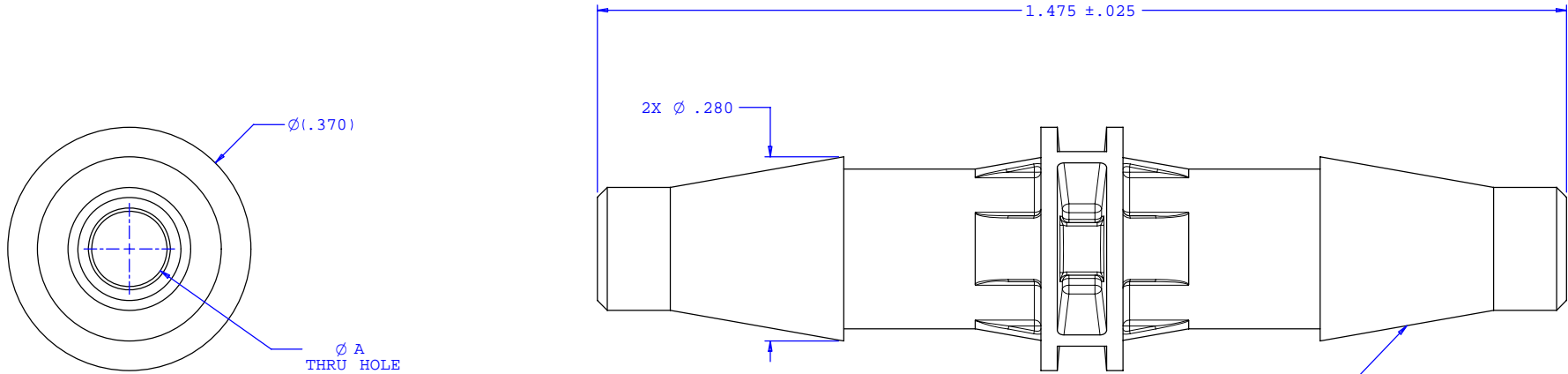

2X INSTRUMENT QUALITY PART. NO PARTING LINE PERMITTED ON THIS CONICAL SURFACE

Dimension	Material Specific Tolerances							
	Acetal	Nylon	PP	ABS	PC	PVC	Polysulfone	J1A
A	.115	.115	.111	.115	.118	.115	.115	.115
B								
C								
D								
E								
F								

UNLESS OTHERWISE SPECIFIED DIMENSIONS ARE IN INCHES TOLERANCES ARE:		<b>VALUE PLASTICS, INC.</b>	
FRACTIONS ±	DECIMALS .XX ±.01 .XXX ±.005 .XXXX ±.001	ANGULAR ±1°	PART NUMBER: <b>5050</b>
DO NOT SCALE DRAWING		DESCRIPTION: Straight Through Connector with Classic Series Barbs, 3/16" (4.75 mm) ID Tubing	
DRAWN BY: <b>Frank Lombardi</b>	DATE: <b>09-01-05</b>	SIZE: <b>B</b> SCALE: <b>NTS</b>	DRAWING NUMBER: <b>1007458</b> REV. <b>B</b>
Engineer/Manager: <b>Rick Cairns</b>		© 2005 VALUE PLASTICS, INC. SHEET: 1 OF 1	

**FOR REFERENCE ONLY**