

NOTES: FOR ADDITIONAL DETAILS, PLEASE CONTACT VP NEW PRODUCT DEVELOPMENT  
DIMENSIONS MARKED  $\varnothing$  ARE CONTROL DIMENSIONS

REVISIONS			
REV.	DESCRIPTION	DATE	APPROVED
A	INITIAL RELEASE	06-12-01	
B	CO 15 Drafting Update	07-11-05	Rick C.
C	ECO 168 - ADDED MATERIAL COMBINATION	06-18-10	S.N.R
D	ECO 227: Obsolete Profax PD626 (-6) Polypropylene	11-12-12	S.N.R

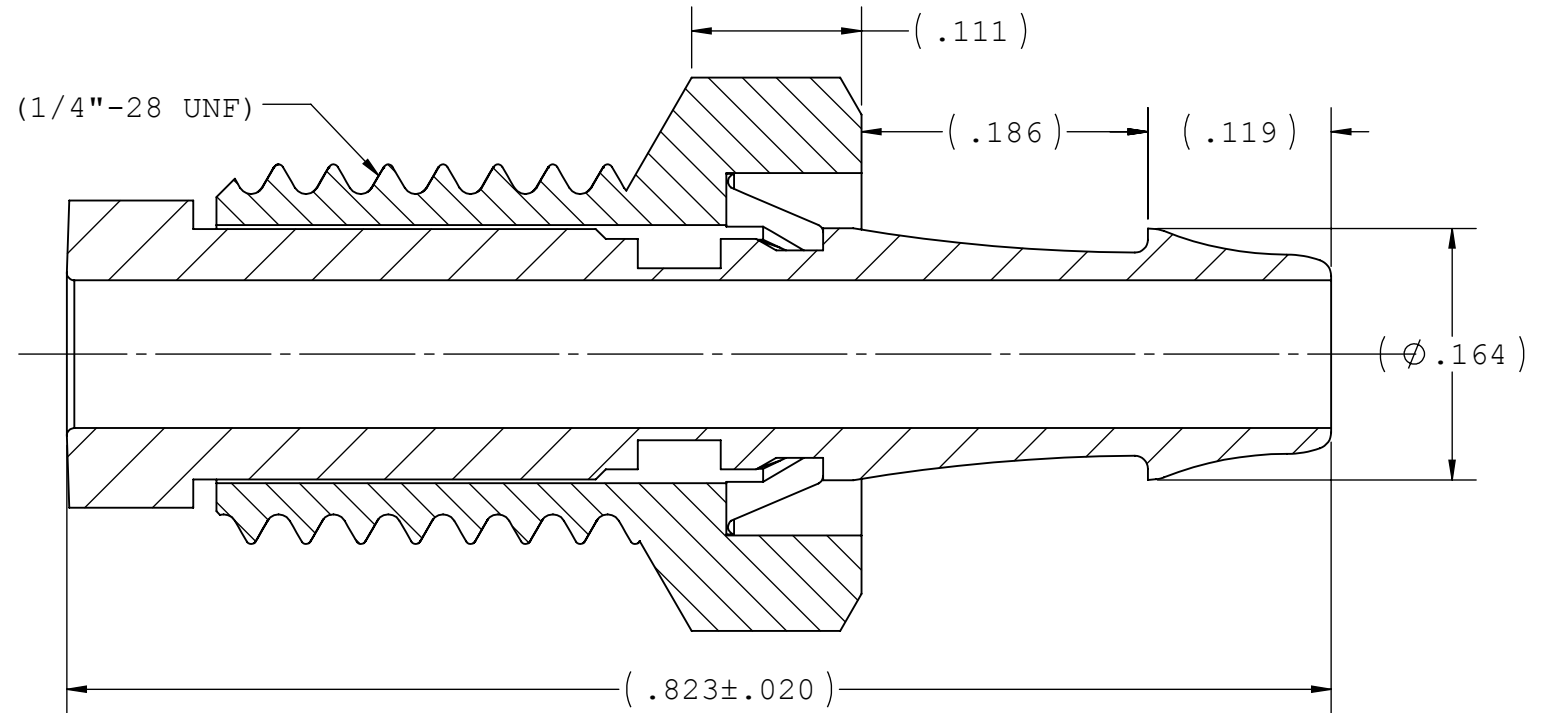

SECTION A-A

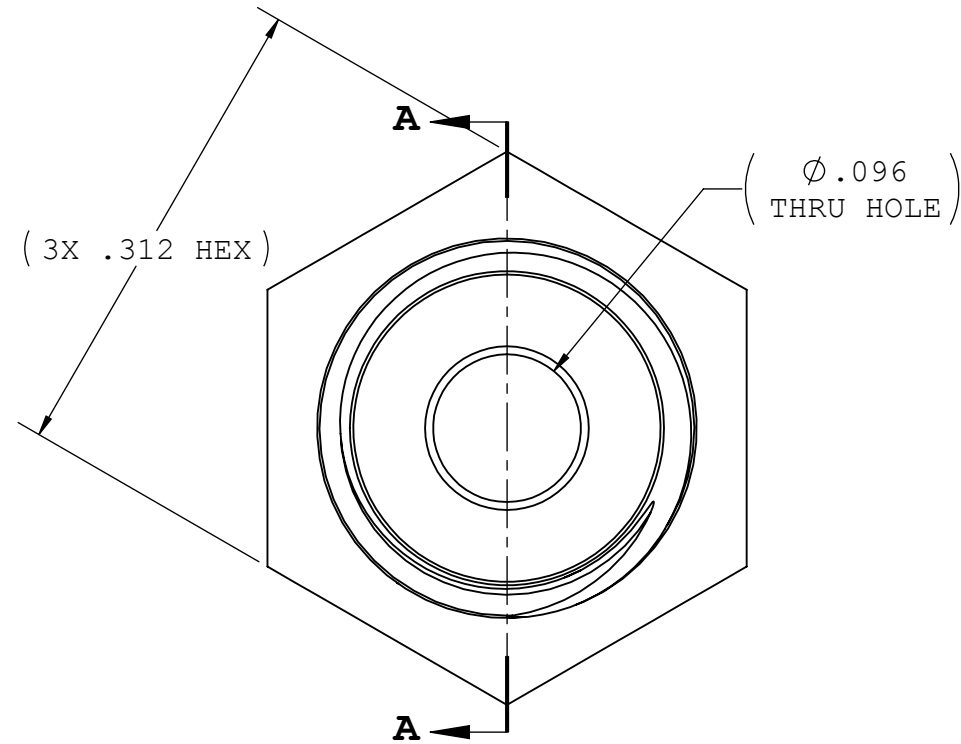
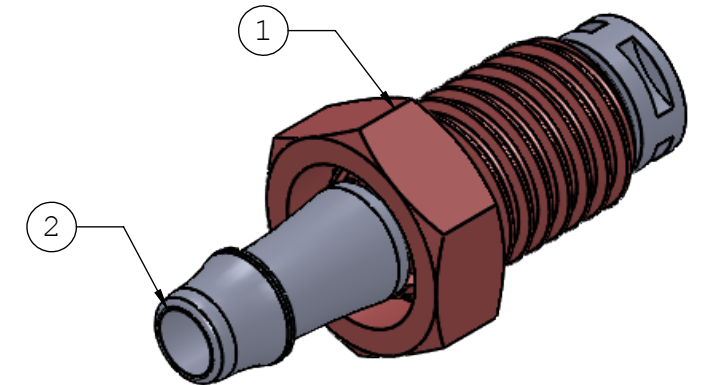

Material Identification			
Assembly Number	Item 1 (RS) Material	Item 2 (BSUB013) Material	Description
ABR013-20-1	White Nylon	Kynar PVDF	ABR013 White Nylon over Kynar PVDF
ABR013-20-2	Black Nylon	Kynar PVDF	ABR013 Black Nylon over Kynar PVDF
ABR013-20-3	Red Nylon	Kynar PVDF	ABR013 Red Nylon over Kynar PVDF
ABR013-20-4	Green Nylon	Kynar PVDF	ABR013 Green Nylon over Kynar PVDF
ABR013-20-5	Blue Nylon	Kynar PVDF	ABR013 Blue Nylon over Kynar PVDF
ABR013-6005-1	White Nylon	Polypropylene	ABR013 White Nylon over Animal Free PP
ABR013-6005-2	Black Nylon	Polypropylene	ABR013 Black Nylon over Animal Free PP
ABR013-6005-3	Red Nylon	Polypropylene	ABR013 Red Nylon over Animal Free PP
ABR013-6005-4	Green Nylon	Polypropylene	ABR013 Green Nylon over Animal Free PP
ABR013-6005-5	Blue Nylon	Polypropylene	ABR013 Blue Nylon over Animal Free PP
ABR013-J1A-1	White Nylon	Kynar PVDF	ABR013 White Nylon over Kynar PVDF
ABR013-J1A-2	Black Nylon	Kynar PVDF	ABR013 Black Nylon over Kynar PVDF
ABR013-J1A-3	Red Nylon	Kynar PVDF	ABR013 Red Nylon over Kynar PVDF
ABR013-J1A-4	Green Nylon	Kynar PVDF	ABR013 Green Nylon over Kynar PVDF
ABR013-J1A-5	Blue Nylon	Kynar PVDF	ABR013 Blue Nylon over Kynar PVDF
ABR013-J1A-J1A	Kynar PVDF	Kynar PVDF	ABR013 Kynar PVDF over Kynar PVDF
ABR013-6012-2	Black Nylon	Black Polypropylene	ABR013 Black Nylon over Black Animal Free PP
ABR013-62-2	Black Nylon	Black Polypropylene	ABR013 Black Nylon over Black Polypropylene

**AQL SPECIFICATIONS:**

- VISUAL INSPECTION FOR DAMAGE
- VERIFY RS ROTATES FREELY (REFER TO RETAINED SAMPLES)
- VERIFY PARTS AND MATERIALS MATCH B.O.M.

ITEM NO.	PART NUMBER	DESCRIPTION	QTY.
1	RS	1/4-28 UNF Bottom Sealing Rotating Thread w/ 5/16" HEX	1
2	BSUB013	500 Series Barb, 1/8" (3mm) ID Tubing	1

UNLESS OTHERWISE SPECIFIED  
DIMENSIONS ARE IN INCHES  
TOLERANCES ARE:

FRACTIONS	DECIMAL	ANGULAR
±	.XX ±.01	± 1°
	.XXX ±.005	
	.XXXX ±.001	

DO NOT SCALE DRAWING

**VALUE PLASTICS, INC**

PART NUMBER: ABR013	
DESCRIPTION: 1/4-28 UNF BOTTOM SEALING ROTATING THREAD WITH 5/16" HEX TO 500 SERIES BARB, 1/8" (3MM) TUBING	
DRAWN BY: kyles	DATE: 11/15/2012
SIZE: B	SCALE: NTS
VER: 1006915	DWG. NO. 1006915
REV: D	
© 2009 VALUE PLASTICS, INC	
SHEET: 1 OF 1	

NEW PRODUCT DEVELOPMENT MGR:  
R. Narayanan

NOTES: FOR ADDITIONAL DETAILS, PLEASE CONTACT VP CUSTOMER SERVICE  
 DIMENSIONS MARKED  $\varnothing$  ARE CONTROL DIMENSIONS

REVISIONS			
REV.	DESCRIPTION	DATE	APPROVED
A	INITIAL RELEASE	06-12-01	
B	CO 15 Drafting Update	07-11-05	Rick C.
C	ECO 168 - ADDED MATERIAL COMBINATION	06-18-10	S.N.R
D	ECO 227: Obsolete Profax PD626 (-6) Polypropylene	11-12-12	S.N.R

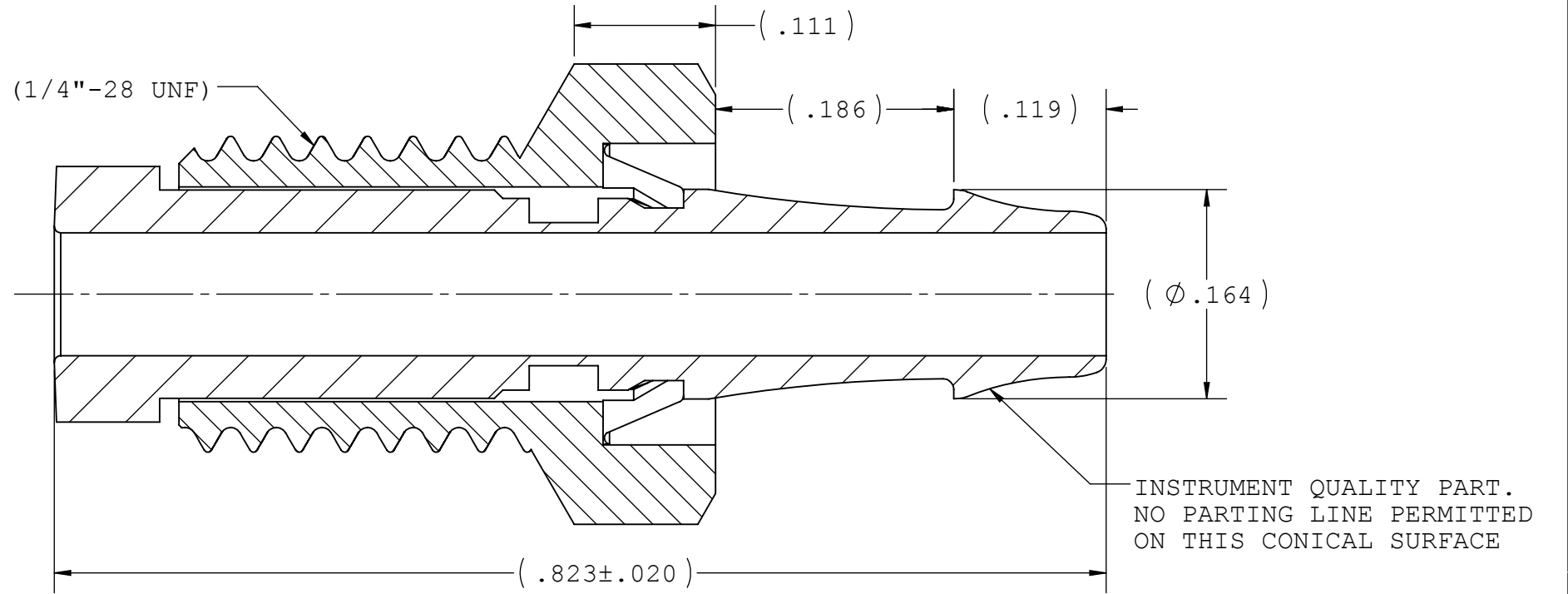
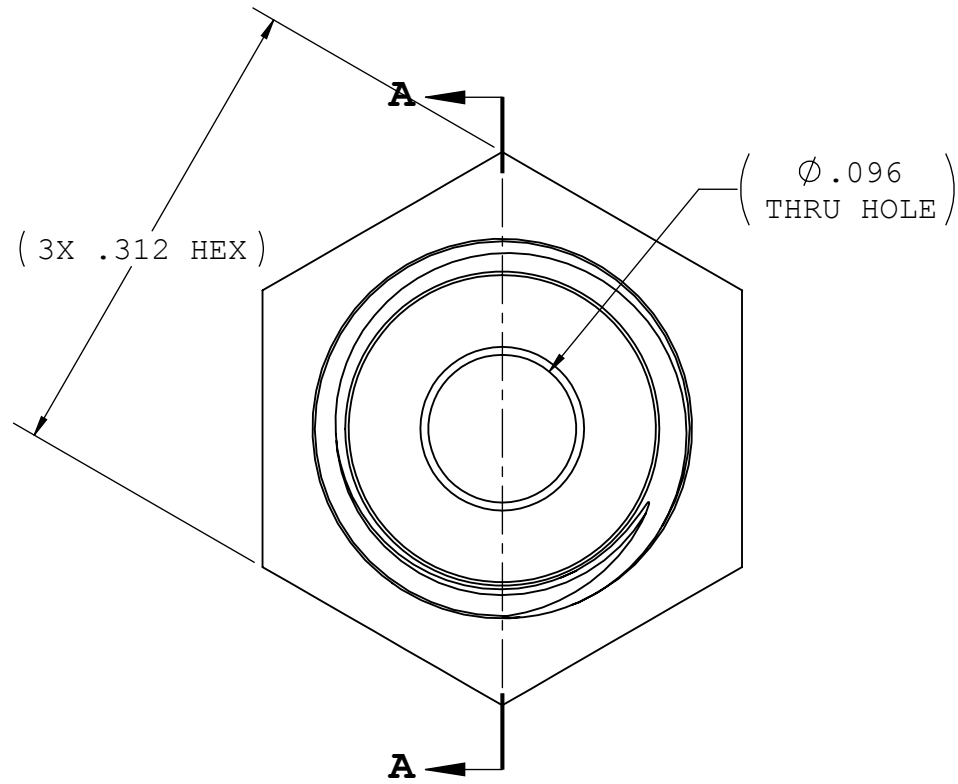

**SECTION A-A**

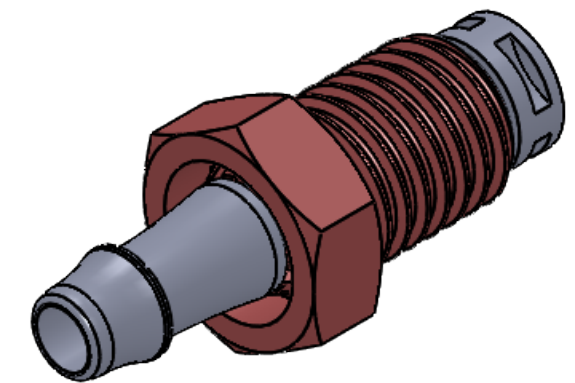

UNLESS OTHERWISE SPECIFIED DIMENSIONS ARE IN INCHES TOLERANCES ARE:		<b>VALUE PLASTICS, INC</b>			
FRACTIONS    DECIMAL    ANGULAR ±            .XX ±.01            ± 1° .XXX ±.005 .XXXX ±.001		PART NUMBER:    ABR013			
DO NOT SCALE DRAWING		DESCRIPTION: 1/4-28 UNF BOTTOM SEALING ROTATING THREAD WITH 5/16" HEX TO 500 SERIES BARB, 1/8" 3MM) TUBING			
DRAWN BY: kyles	DATE: 11/15/2012	SIZE: <b>B</b>	SCALE: NTS	VER: 	DWG. NO.    REV 1006915    D
NEW PRODUCT DEVELOPMENT MGR: R. Narayanan		© 2009 VALUE PLASTICS, INC			SHEET:    1 OF 1

**FOR REFERENCE ONLY**