

NOTE: FOR MORE DETAILS SEE YOUR V.P. CUSTOMER SERVICE REP.

REVISIONS			
REV.	DESCRIPTION	DATE	APPROVED
A	INITIAL RELEASE	05-19-98	
B	CO 027 Drafting Update	10-10-05	Rick C.

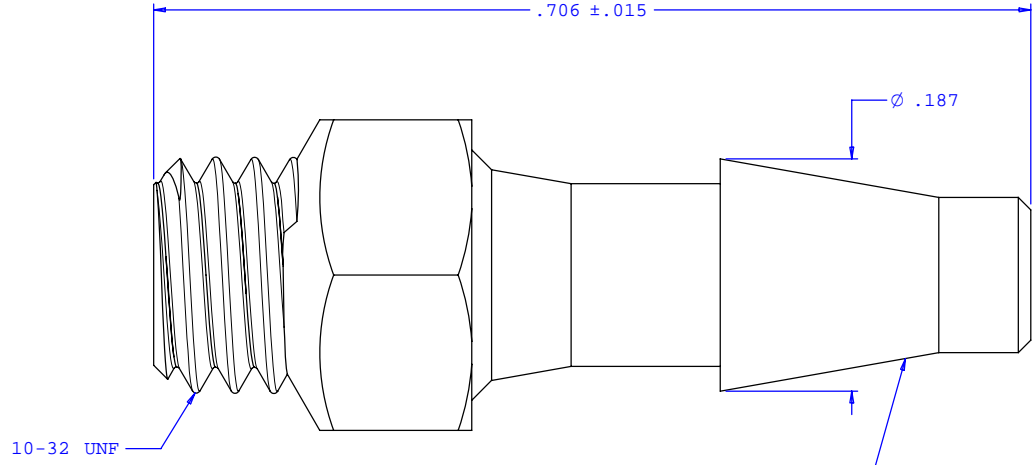

INSTRUMENT QUALITY PART. NO PARTING LINE PERMITTED ON THIS CONICAL SURFACE

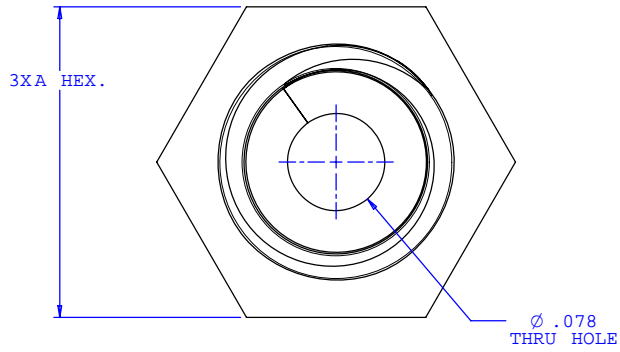
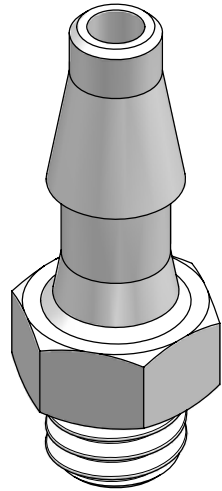

Dimension	Material Specific Tolerances							
	Acetal	Nylon	PP	ABS	PC	PVC	Polysulfone	J1A
A	.250	.246	.250	.250	.250	.250	.250	.250
B								
C								
D								
E								
F								

UNLESS OTHERWISE SPECIFIED DIMENSIONS ARE IN INCHES TOLERANCES ARE:		VALUE PLASTICS, INC.	
FRACTIONS ±	DECIMALS .XX ±.01 .XXX ±.005 .XXXX ±.001	ANGULAR ±1°	PART NUMBER: B
DO NOT SCALE DRAWING		DESCRIPTION: 10-32 UNF Thread with 1/4" Hex to Classic Series Barb, 1/8" (3 mm) ID Tubing	
DRAWN BY: Frank Lombardi	DATE: 09-01-05	SIZE: B SCALE: NTS	DRAWING NUMBER: 1007463 REV. B
Engineer/Manager: Rick Cairns		© 2005 VALUE PLASTICS, INC. SHEET: 1 OF 1	

FOR REFERENCE ONLY