

NOTE: FOR MORE DETAILS SEE YOUR V.P.CUSTOMER SERVICE REP.

REVISIONS			
REV.	DESCRIPTION	DATE	APPROVED
A	INITIAL RELEASE	07-27-00	
B	CO 018 Drafting Update	07-11-05	Rick C.

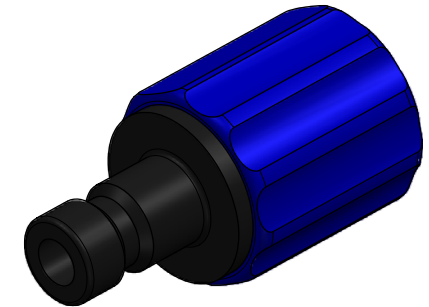
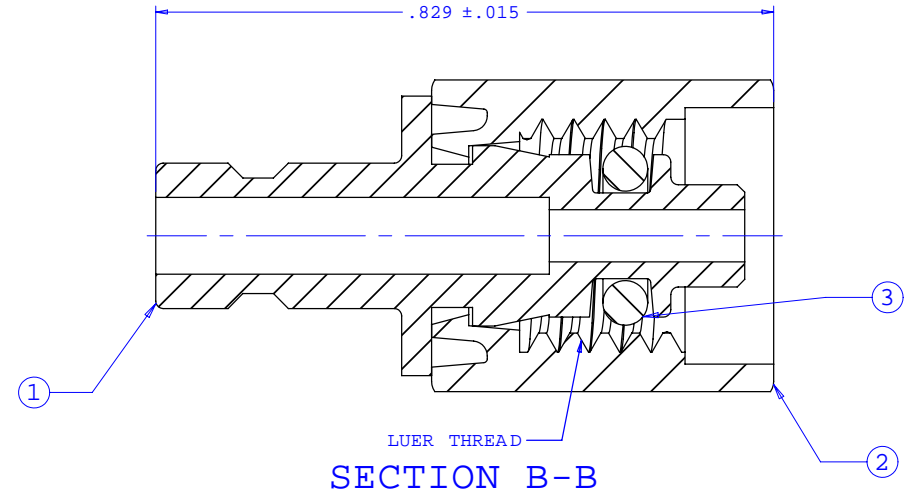
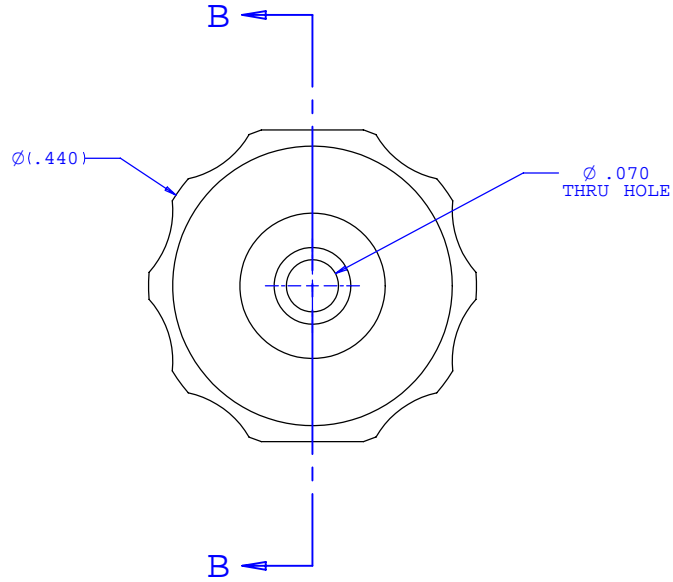

Item Number	Part Number	Rev.	Description	Quantity
1	BPIM	A	Blood Pressure Internal to Monitor Adaptor	1
2	BPN		Blood Pressure Locking Nut	1
3	5W2-0021		Blood Pressure O-Ring for BPA Fittings	1

UNLESS OTHERWISE SPECIFIED DIMENSIONS ARE IN INCHES TOLERANCES ARE:		VALUE PLASTICS, INC.	
FRACTIONS ±	DECIMALS .XX ±.01 .XXX ±.005 .XXXX ±.001	ANGULAR ±1°	PART NUMBER: BPAM
DO NOT SCALE DRAWING		DESCRIPTION: Blood Pressure Monitor Connector Bayonet to Internal 5/16-24 UNF Thread and O-Ring	
DRAWN BY: Frank Lombardi	DATE: 06-03-05	SIZE: B SCALE: NTS	DRAWING NUMBER: 1006852 REV. B
Engineer/Manager: Rick Cairns		© 2005 VALUE PLASTICS, INC. SHEET: 1 OF 1	

FOR REFERENCE ONLY