

NOTE: FOR MORE DETAILS SEE YOUR V.P.CUSTOMER SERVICE REP.

REVISIONS			
REV.	DESCRIPTION	DATE	APPROVED
A	INITIAL RELEASE	11-24-99	
B	CO 018 Drafting Update	07-11-05	Rick C.

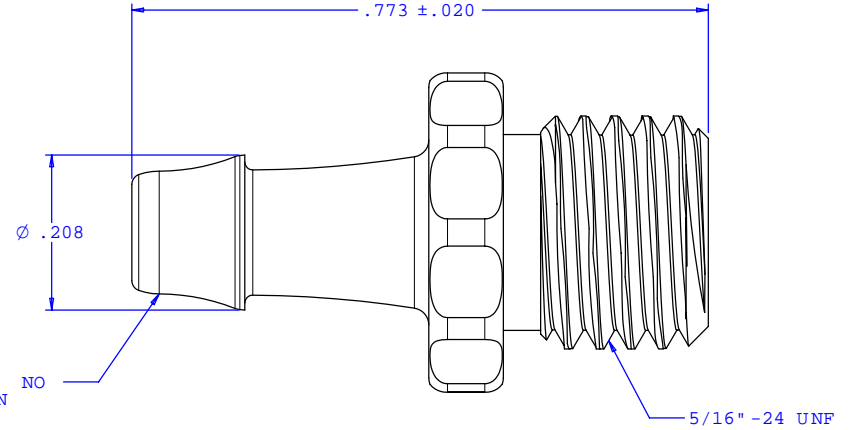

INSTRUMENT QUALITY PART.
PARTING LINE PERMITTED ON
THIS CONICAL SURFACE

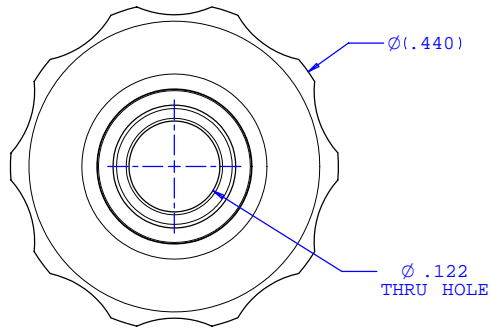
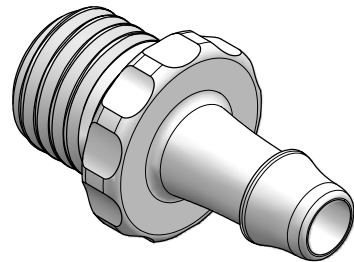

UNLESS OTHERWISE SPECIFIED DIMENSIONS ARE IN INCHES TOLERANCES ARE:		VALUE PLASTICS, INC.	
FRACTIONS ±	DECIMALS .XX ±.01 .XXX ±.005 .XXXX ±.001	ANGULAR ±1°	PART NUMBER: BPC025
DO NOT SCALE DRAWING		DESCRIPTION: Blood Pressure Adapter with 5/16-24 UNF Thread to 500 Series Barb, 5/32" (4 mm) ID Tubing	
DRAWN BY: Frank Lombardi	DATE: 06-06-05	SIZE: B	SCALE: NTS
Engineer Manager: Rick Cairns		DRAWING NUMBER: 1006856	REV. B
© 2005 VALUE PLASTICS, INC.		SHEET: 1 OF 1	

FOR REFERENCE ONLY