

NOTES: FOR MORE DETAILS SEE YOUR V.P. SERVICE REP.

REVISIONS			
REV.	DESCRIPTION	DATE	APPROVED
A	INITIAL RELEASE 02-18-02	08-22-06	Rick C.
B	Increased draft and shortened cylindrical coring of Luer post	01-18-08	Rick C.

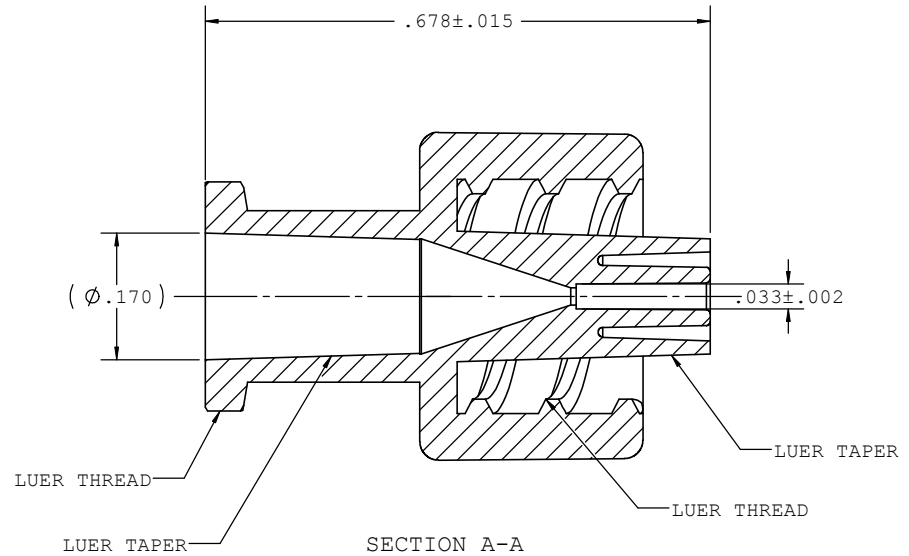
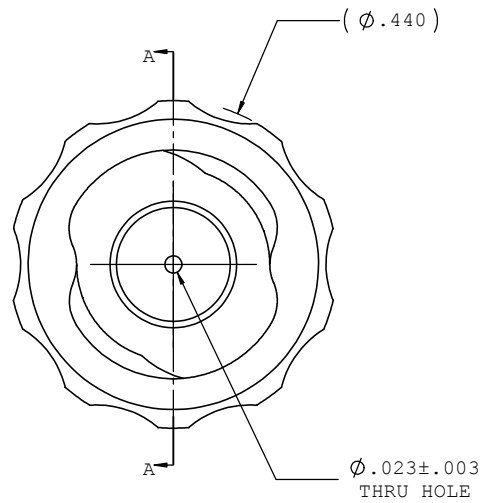

UNLESS OTHERWISE SPECIFIED DIMENSIONS ARE IN INCHES TOLERANCES ARE:		VALUE PLASTICS, INC			
FRACTIONS DECIMAL ANGULAR ± .XX ±.01 ± 1° .XXX ±.005 .XXXX ±.001		PART NUMBER: CF235			
DO NOT SCALE DRAWING		DESCRIPTION:			
DRAWN BY:	DATE:	SIZE:	SCALE:	VER:	DWG. NO.
		B	NTS		1008964
NEW PRODUCT DEVELOPMENT MGR: R. Narayanan		© 2007 VALUE PLASTICS, INC			REV: B
				SHEET:	1 OF 1

FOR REFERENCE ONLY