

NOTES: FOR MORE DETAILS SEE YOUR V.P. SERVICE REP.

REVISIONS			
REV.	DESCRIPTION	DATE	APPROVED
A	Initial Release	09-09-15	H.Lou
B	ECO 324	02-17-16	FJL
C	ECO 390	02-15-19	FJL

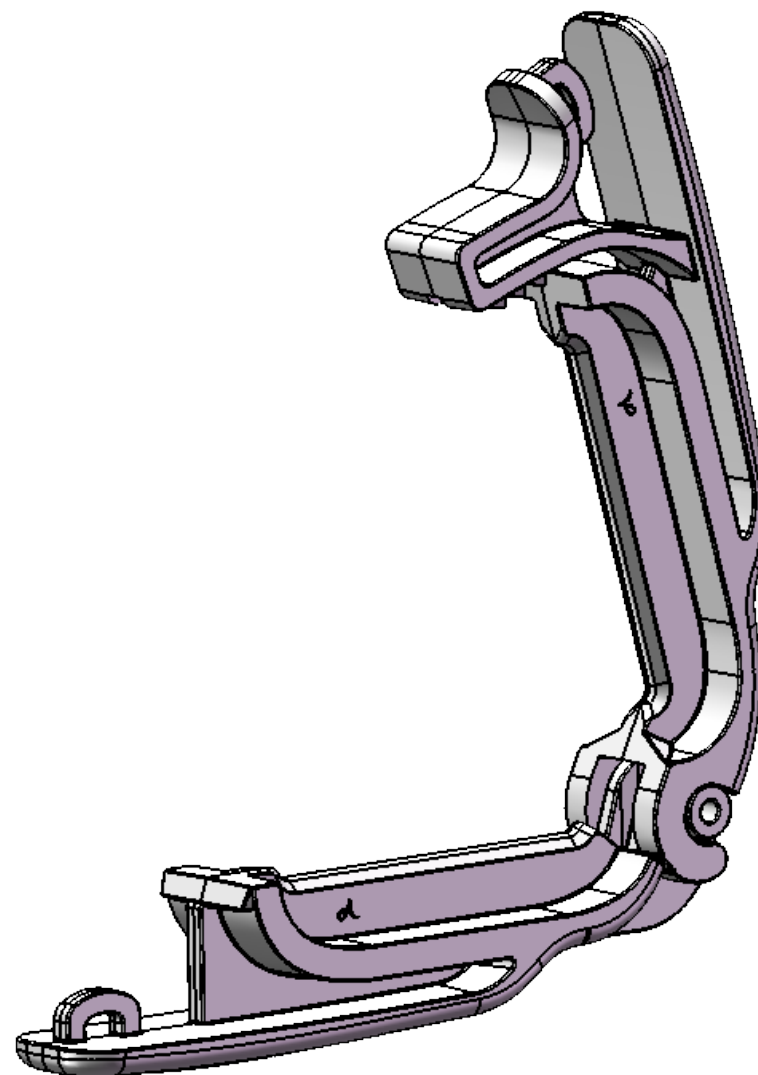
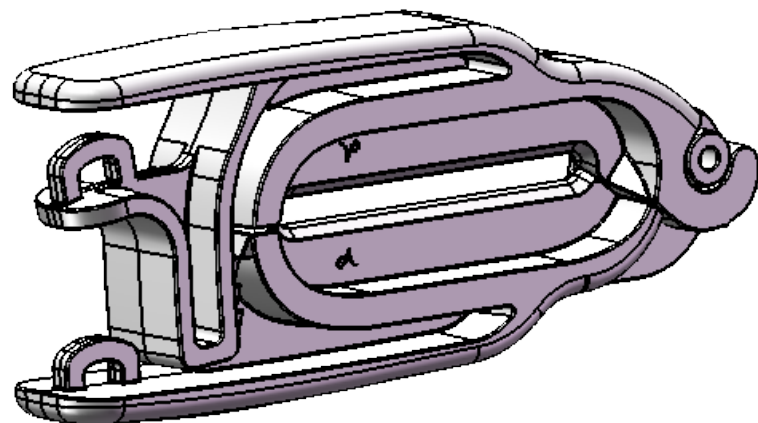
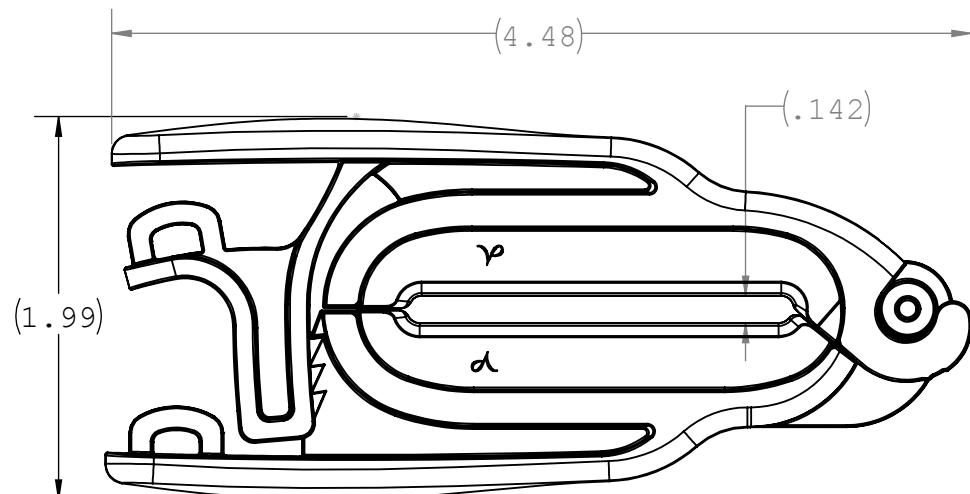
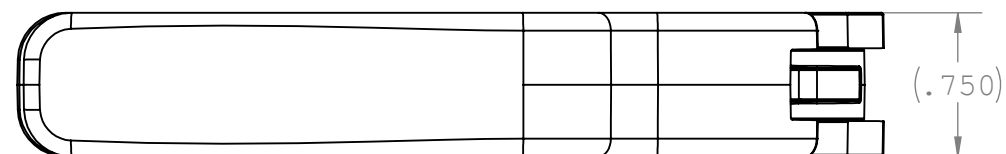

UNLESS OTHERWISE SPECIFIED DIMENSIONS ARE IN INCHES TOLERANCES ARE:		<b>VALUE PLASTICS, INC</b>			
FRACTIONS    DECIMAL    ANGULAR ±            .XX ±.01            ± 1° .XXX ±.005 .XXXX ±.001		PART NUMBER: CPT100			
DO NOT SCALE DRAWING		DESCRIPTION: PharmaLok Tube Clamp for ½ to 1-¼ inch Tubing			
DRAWN BY: T. Whitaker	DATE: 2/15/2019	SIZE: <b>B</b>	SCALE: NTS	VER: 	DWG. NO. 1034225
MANAGER: huadong.lou		© 2011 VALUE PLASTICS, INC			REV C
				SHEET: 1 OF 1	

**FOR REFERENCE ONLY**