

NOTES: FOR ADDITIONAL DETAILS, PLEASE CONTACT VP CUSTOMER SERVICE
 DIMENSIONS MARKED \square ARE CONTROL DIMENSIONS

| REVISIONS | | | |
|-----------|-----------------|----------|----------|
| REV. | DESCRIPTION | DATE | APPROVED |
| A | Initial Release | 07-11-18 | FJL |

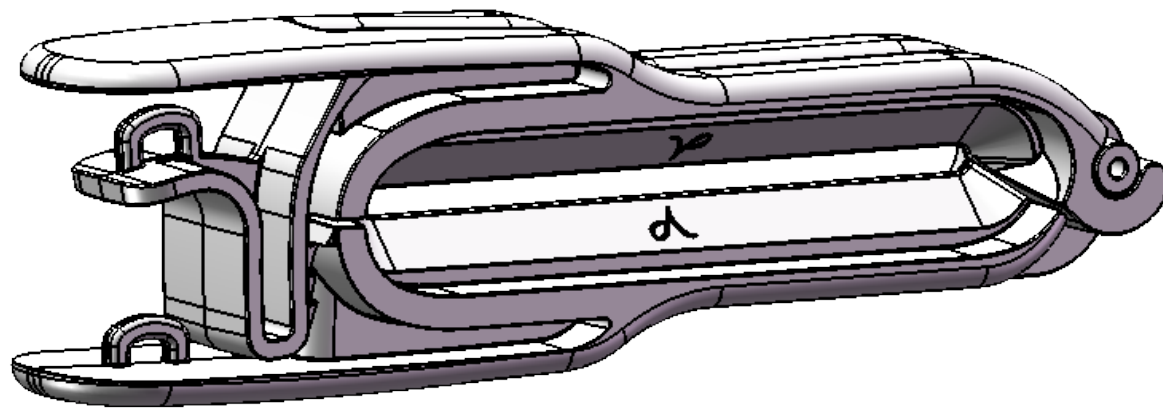
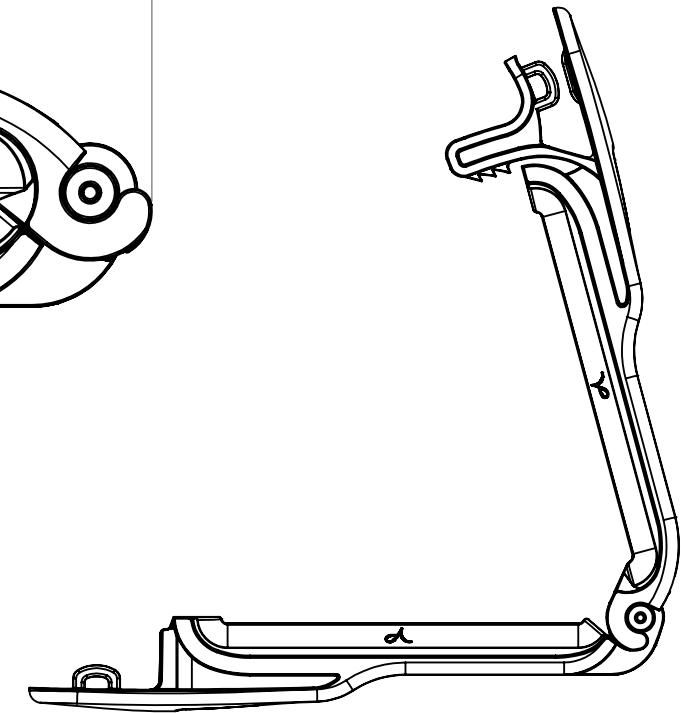
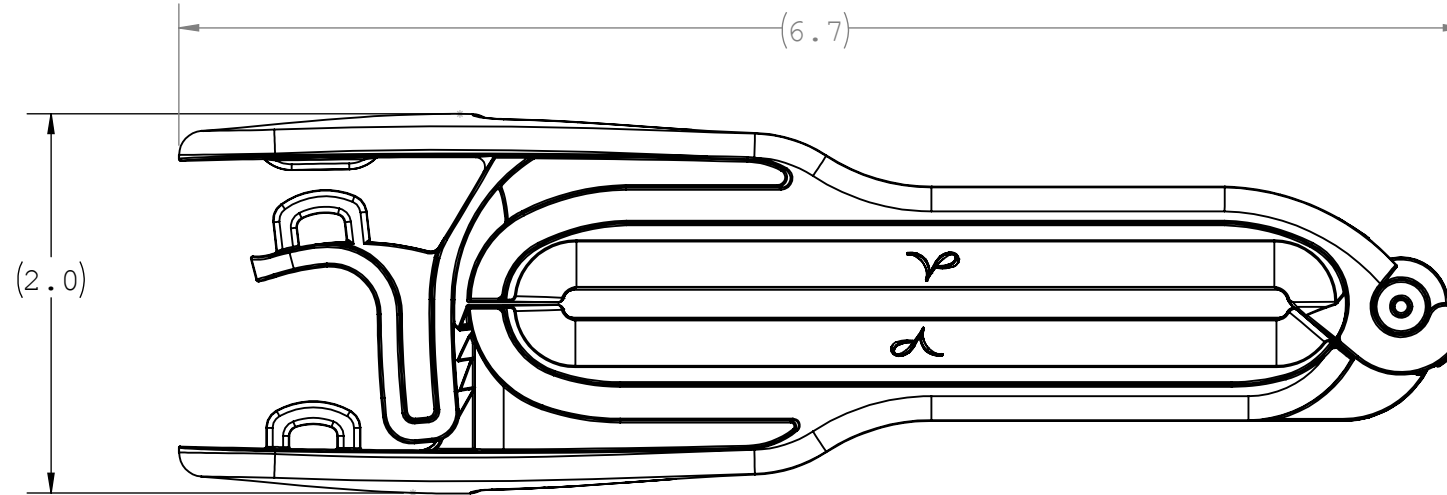
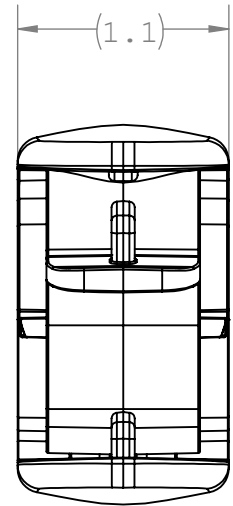

| | | | | | |
|--|--------------------|---|---------------|--------|---------------------|
| UNLESS OTHERWISE SPECIFIED DIMENSIONS ARE IN INCHES TOLERANCES ARE: | | VALUE PLASTICS, INC | | | |
| FRACTIONS DECIMAL ANGULAR \pm .XX \pm .01 \pm 1° .XXX \pm .005 .XXXX \pm .001 | | PART NUMBER: CPT110 | | | |
| DO NOT SCALE DRAWING | | DESCRIPTION: Pharmedok Large Tube Clamp | | | |
| DRAWN BY: CTW | DATE: 7/11/2018 | SIZE: B | SCALE: NTS | VER: | DWG. NO. 1046817 |
| MANAGER: F. Lombardi | | © 2014 VALUE PLASTICS, INC | | | REV A |
| | | | | SHEET: | 1 OF 1 |

FOR REFERENCE ONLY