

NOTE: FOR MORE DETAILS SEE YOUR V.P.CUSTOMER SERVICE REP.

REVISIONS			
REV.	DESCRIPTION	DATE	APPROVED
A	INITIAL RELEASE	07-25-97	
B	CO 012 Core Center Rib	05-04-05	Rick C.

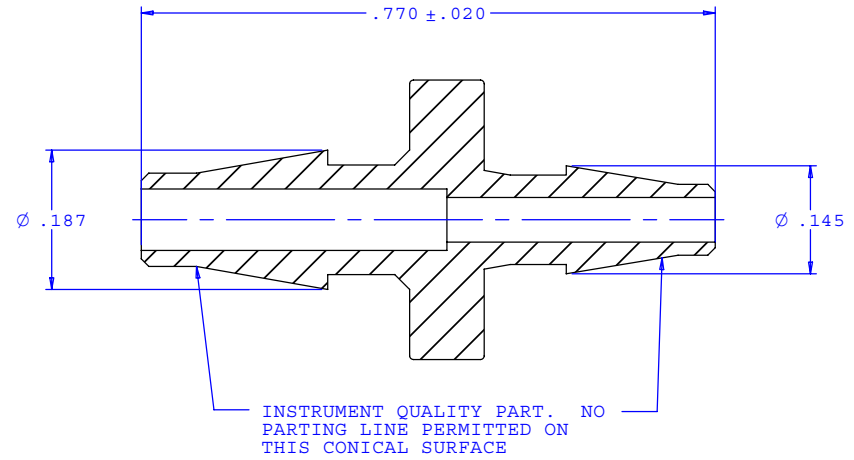

SECTION B-B

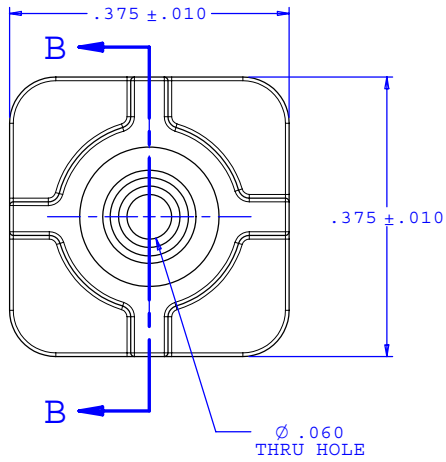
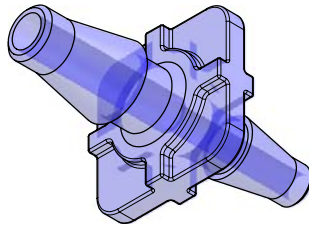

UNLESS OTHERWISE SPECIFIED DIMENSIONS ARE IN INCHES TOLERANCES ARE:		VALUE PLASTICS, INC.	
FRACTIONS ±	DECIMALS .XX ±.01 .XXX ±.005 .XXXX ±.001	ANGULAR ±1°	PART NUMBER: DC
DO NOT SCALE DRAWING		DESCRIPTION: Straight Through Reduction Connector with Classic Series Barbs, 1/8" (3 mm) and 3/32" (2.25 mm) ID Tubing	
DRAWN BY: Bob Bliven	DATE: 02-07-05	SIZE: B	SCALE: NTS
ENGINEER MANAGER: Rick Cairns	DATE: 02-07-05	DRAWING NUMBER: 1005633	REV. B
© 2004 VALUE PLASTICS, INC.		SHEET: 1 of 1	

FOR REFERENCE ONLY