

NOTES: FOR MORE DETAILS SEE YOUR V.P. SERVICE REP.

REVISIONS			
REV.	DESCRIPTION	DATE	APPROVED
A	INITIAL RELEASE	01/31/08	R. Cairns
B	Updated Assembly Drawing to VP Standards	03/13/09	R. Cairns
C	ECO-132 New Weld Joint Design	10/05/09	R. Cairns
D	ECO 393	02-12-20	FJL

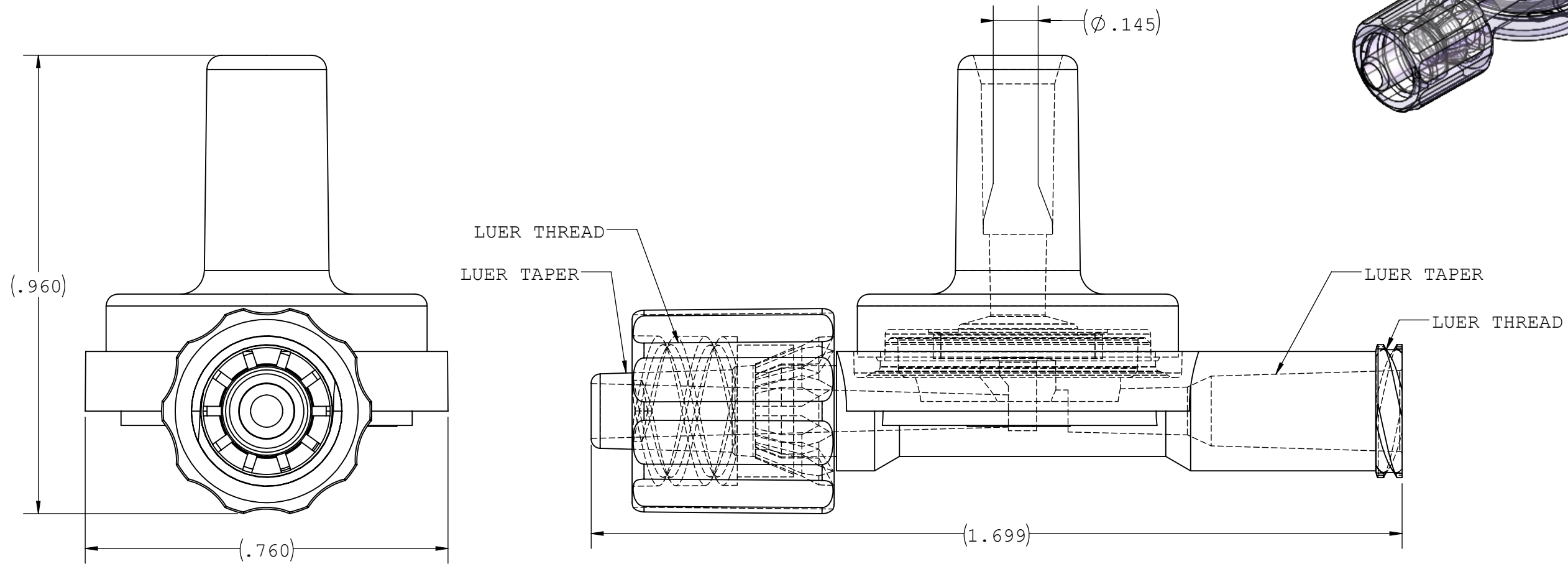

UNLESS OTHERWISE SPECIFIED DIMENSIONS ARE IN INCHES TOLERANCES ARE:		VALUE PLASTICS, INC			
FRACTIONS ±	DECIMAL . XX ±.01 .XXX ±.005 .XXXX ±.001	ANGULAR ± 1°	PART NUMBER: DCV115		
DO NOT SCALE DRAWING			DESCRIPTION: Double Check Valve, Style 115		
DRAWN BY: Kyle.Steele	DATE: 2/12/2020	SIZE: B	SCALE: NTS	VER: 	DWG. NO. 1012670
ENGINEERING MANAGER: Frank.Lombardi		© 2008 VALUE PLASTICS, INC		SHEET: 1 of 1	

FOR REFERENCE ONLY