

NOTE: FOR MORE DETAILS SEE YOUR V.P.CUSTOMER SERVICE REP.

REVISIONS			
REV.	DESCRIPTION	DATE	APPROVED
A	INITIAL RELEASE	09-18-02	
B	CO 013 Drafting Update	05-02-05	Rick C.

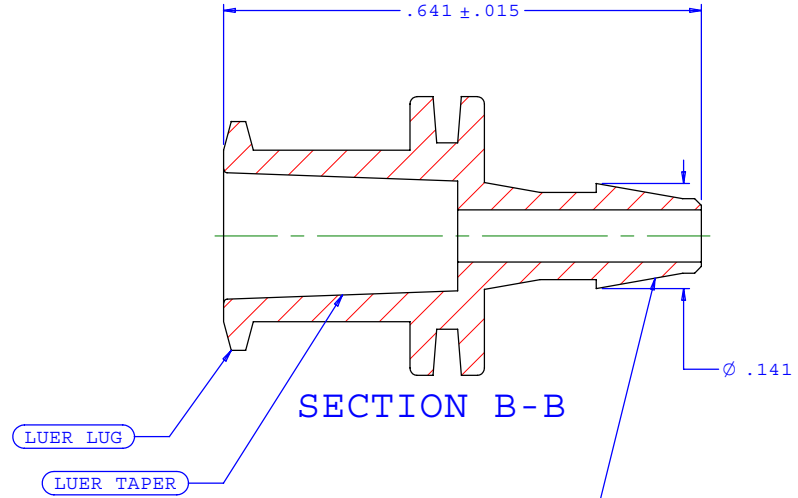

INSTRUMENT QUALITY PART. NO PARTING LINE PERMITTED ON THIS CONICAL SURFACE

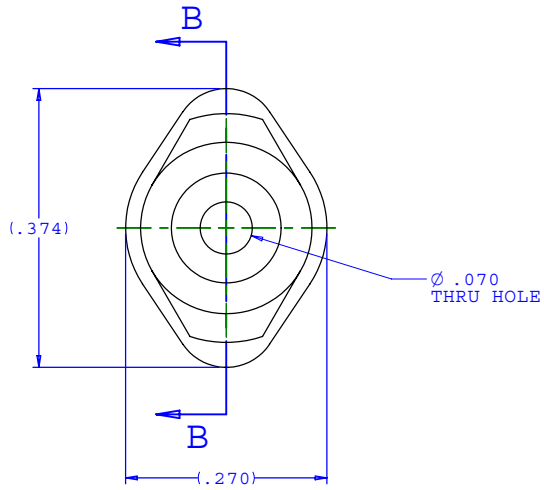

Dimension	Material Specific Tolerances							
	Acetal	Nylon	PP	ABS	PC	PVC	Polysulfone	J1A
A								±.020
B								±.025
C								
D								
E								
F								

UNLESS OTHERWISE SPECIFIED DIMENSIONS ARE IN INCHES TOLERANCES ARE:		VALUE PLASTICS, INC.	
FRACTIONS ±	DECIMALS .XX ±.01 .XXX ±.005 .XXXX ±.001	ANGULAR ±1°	PART NUMBER: FTL220
DO NOT SCALE DRAWING		DESCRIPTION: Female Luer Lug Style to 200 Series Barb, 3/32" (2.25 mm) ID Tubing	
DRAWN BY: Frank Lombardi 4-18-05	DATE:	SIZE: B	SCALE: NTS
ENGINEER MANAGER: Rick Cairns		DRAWING NUMBER: 1005486	REV. B
© 2004 VALUE PLASTICS, INC.			SHEET: 1 OF 1

FOR REFERENCE ONLY