

NOTE: FOR MORE DETAILS SEE YOUR V.P. CUSTOMER SERVICE REP.

REVISIONS			
REV.	DESCRIPTION	DATE	APPROVED
A	INITIAL RELEASE	01-30-98	
B	CO 013 Drafting Update	05-04-05	Rick C.

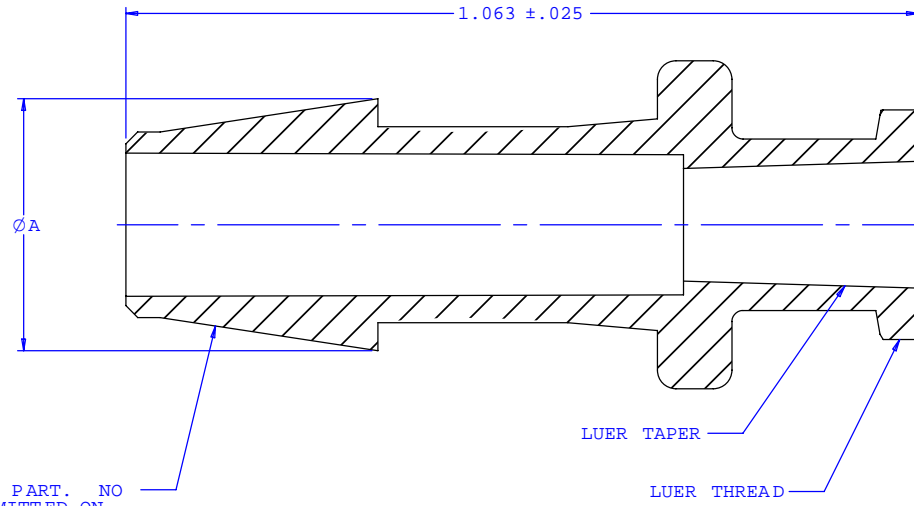
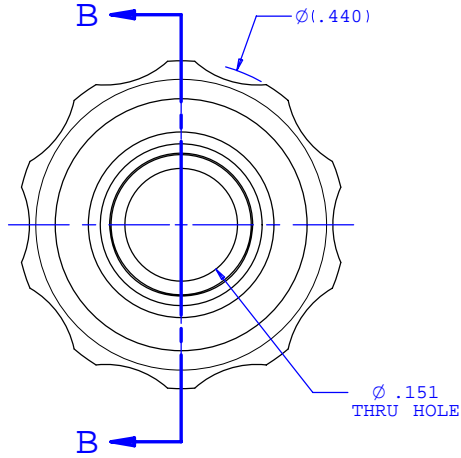

INSTRUMENT QUALITY PART. NO PARTING LINE PERMITTED ON THIS CONICAL SURFACE

SECTION B-B



Dimension	Material Specific Tolerances							
	Acetal	Nylon	PP	ABS	PC	PVC	Polysulfone	J1A
A	.338	.338	.333	.338	.338	.338	.338	.338
B								
C								
D								
E								
F								

UNLESS OTHERWISE SPECIFIED DIMENSIONS ARE IN INCHES TOLERANCES ARE:		VALUE PLASTICS, INC.	
FRACTIONS ±	DECIMALS ±	ANGULAR ±1°	PART NUMBER: FTLL360
.XX	±.01		DESCRIPTION: Female Luer Thread Style to 300 Series Barb, 1/4" (6.25 mm) ID Tubing
.XXX	±.005		
.XXXX	±.001		
DO NOT SCALE DRAWING			
DRAWN BY: Frank Lombardi 4-18-05	DATE:	SIZE: B	SCALE: NTS
Engineer/Manager: Rick Cairns		DRAWING NUMBER: 1005587	REV. B
© 2004 VALUE PLASTICS, INC.			SHEET: 1 OF 1

FOR REFERENCE ONLY