

NOTE: FOR MORE DETAILS SEE YOUR V.P.CUSTOMER SERVICE REP.

REVISIONS			
REV.	DESCRIPTION	DATE	APPROVED
A	INITIAL RELEASE	02-03-98	
B	CO 016 Drafting Update	06-14-05	Rick C.

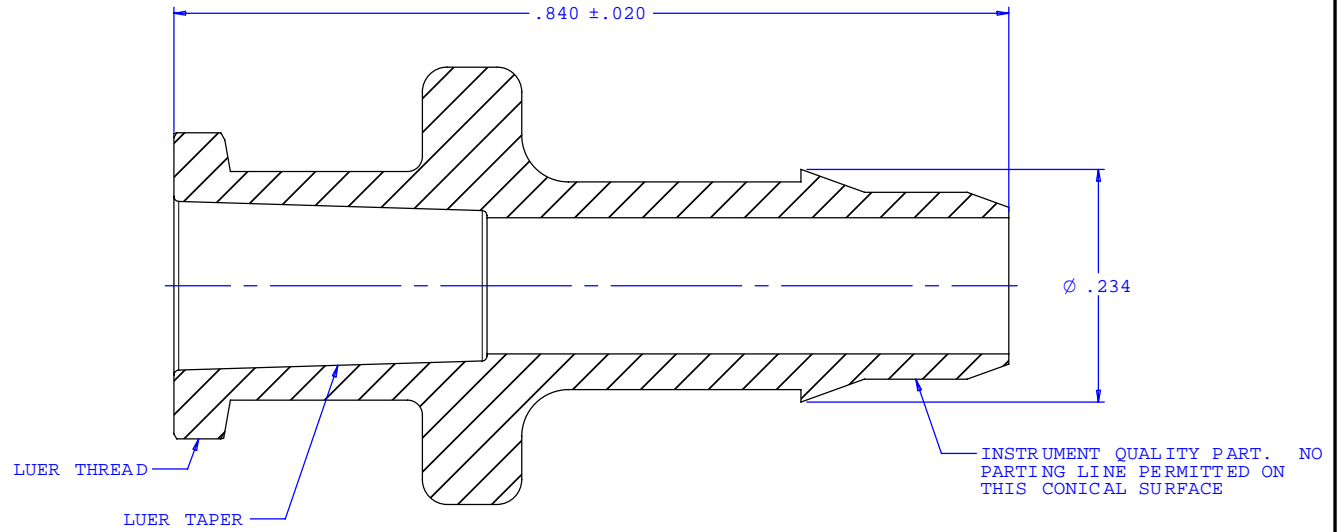

SECTION B-B

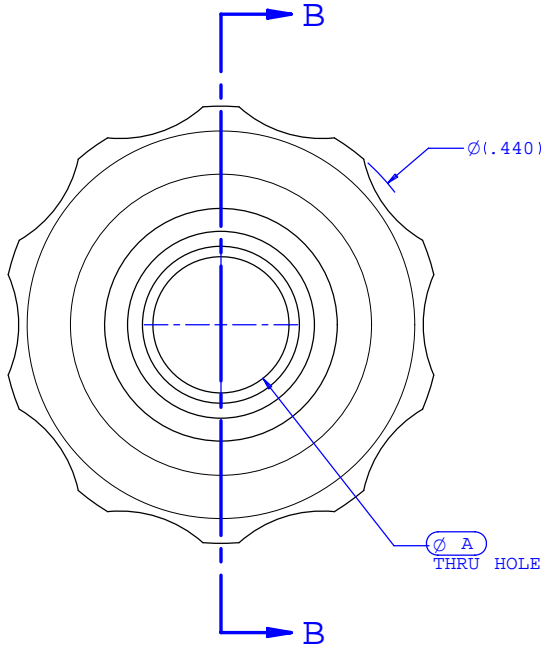
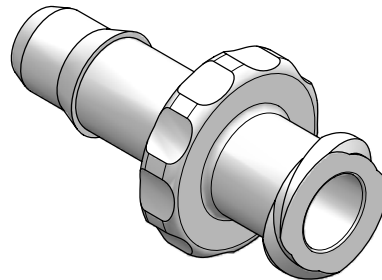

Dimension	Material Specific Tolerances							
	Acetal	Nylon	PP	ABS	PC	PVC	Polysulfone	J1A
A	.137	.131	.137	.137	.137	.137	.137	.131
B								
C								
D								
E								
F								

UNLESS OTHERWISE SPECIFIED DIMENSIONS ARE IN INCHES TOLERANCES ARE:		<b>VALUE PLASTICS, INC.</b>	
FRACTIONS ±	DECIMALS .XX ±.01 .XXX ±.005 .XXXX ±.001	ANGULAR ±1°	PART NUMBER: <b>FTLL450</b>
DO NOT SCALE DRAWING		DESCRIPTION: Female Luer Thread to 400 Series Barb, 3/16" (4.75 mm) ID Tubing	
DRAWN BY: <b>Frank Lombardi 05-09-05</b>	DATE:	SIZE: <b>B</b>	SCALE: <b>NTS</b>
Engineer/Manager: <b>Rick Cairns</b>		DRAWING NUMBER: <b>1006646</b>	REV. <b>B</b>
© 2005 VALUE PLASTICS, INC.			SHEET: 1 OF 1

**FOR REFERENCE ONLY**