

NOTE: FOR MORE DETAILS SEE YOUR V.P.CUSTOMER SERVICE REP.

REVISIONS			
REV.	DESCRIPTION	DATE	APPROVED
A	INITIAL RELEASE	05-14-98	
B	CO 031 Drafting Update	01-17-06	Rick C.

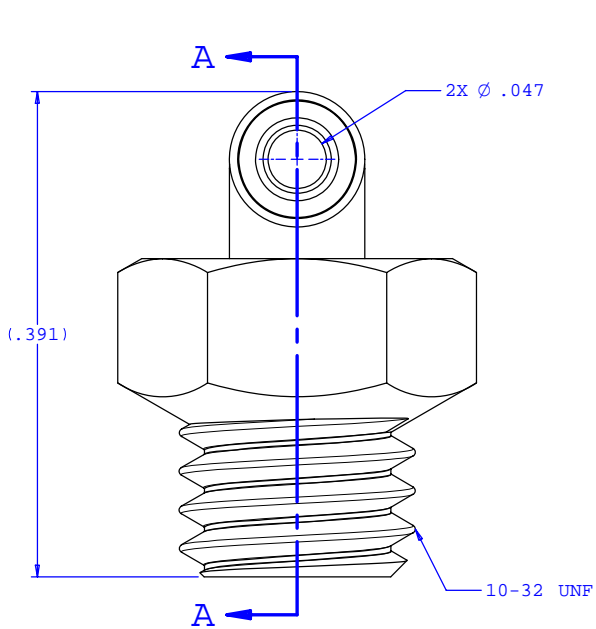

2X INSTRUMENT QUALITY PART. NO PARTING LINE PERMITTED ON THIS CONICAL SURFACE

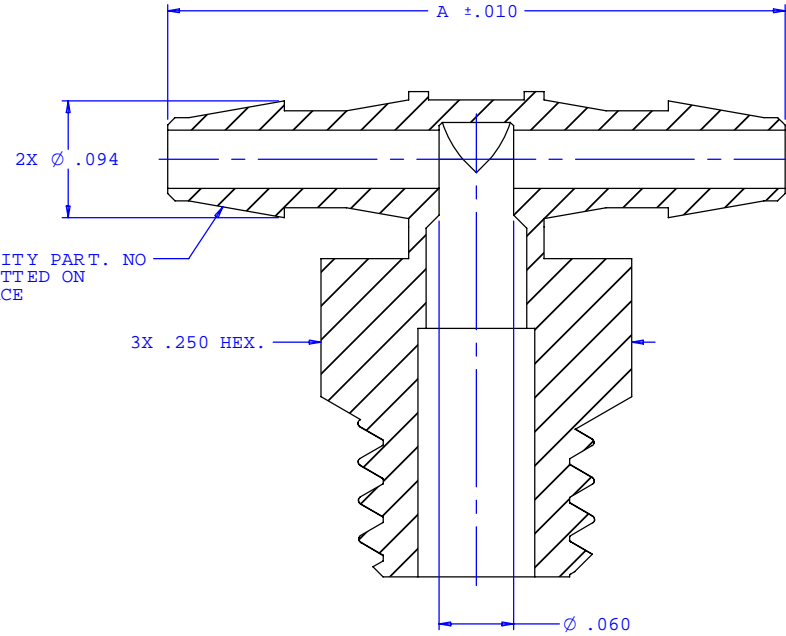

SECTION A-A

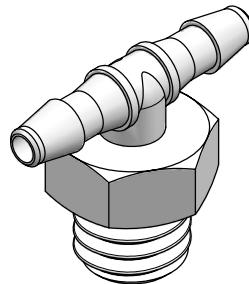

Dimension	Material Specific Tolerances							
	Acetal	Nylon	PP	ABS	PC	PVC	Polysulfone	J1A
A	.497	.508	.497	.497	.497	.497	.497	.497
B								
C								
D								
E								
F								

UNLESS OTHERWISE SPECIFIED DIMENSIONS ARE IN INCHES TOLERANCES ARE:		VALUE PLASTICS, INC.	
FRACTIONS ±	DECIMALS ±	ANGULAR ±1°	PART NUMBER: KT210
.XX ±.01	.XXX ±.005	.XXXX ±.001	DESCRIPTION: 10-32 UNF Thread Tee with 1/4" Hex to 200 Series Barb, 1/16" (1.5 mm) ID Tubing
DO NOT SCALE DRAWING			REV. B
DRAWN BY: Frank Lombardi	DATE: 11-05-05	SIZE: B SCALE: NTS	DRAWING NUMBER: 1007801
Engineer/Manager: Rick Cairns		© 2005 VALUE PLASTICS, INC. SHEET: 1 OF 1	

FOR REFERENCE ONLY