

REVISIONS			
REV	DESCRIPTION	DATE	APPROVED

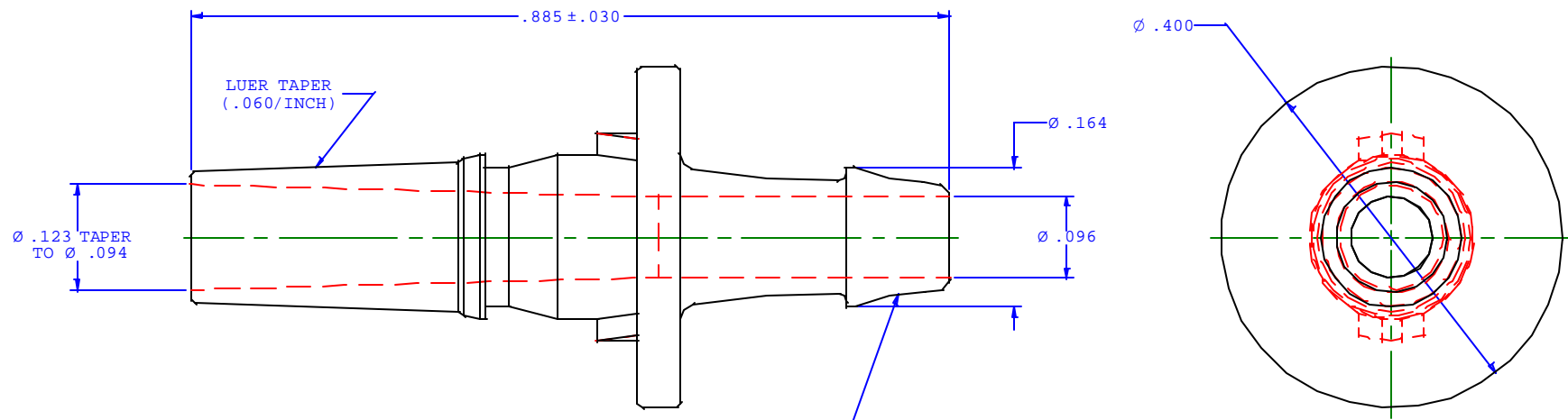

INSTRUMENT QUALITY PART.
NO PARTING LINE ALLOWED ON
THIS CRITICAL SURFACE.

UNLESS OTHERWISE SPECIFIED DIMENSIONS ARE IN INCHES TOLERANCES ARE:		VALUE PLASTICS, INC.	
FRACTIONS ±	DECIMALS .XX ± .01 .XXX ± .005	ANGULAR ±1°	PART NUMBER: MLSL013
DO NOT SCALE DRAWING		DESCRIPTION: Male Luer to 500 Series Barb, 1/8" (3 mm) ID Tubing (May be used with separate stationary lock ring: FSLLR)	
DRAWN BY: SUE CORAM	SCALE: NTS	DRAWING NUMBER:	REV.
DATE: 08/21/97	© 1997 VALUE PLASTICS, INC.		SHEET:

FOR REFERENCE ONLY