

REVISIONS			
REV	DESCRIPTION	DATE	APPROVED

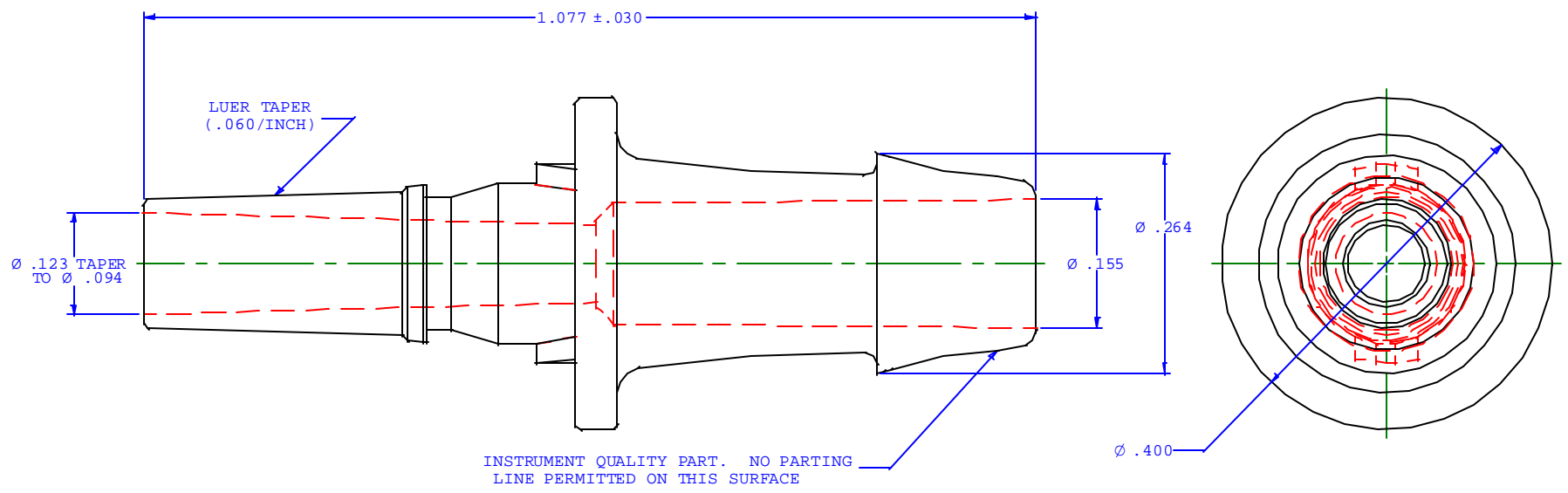

UNLESS OTHERWISE SPECIFIED DIMENSIONS ARE IN INCHES TOLERANCES ARE:		VALUE PLASTICS, INC.	
FRACTIONS ±	DECIMALS .XX ±.01 .XXX ±.005	ANGULAR ±1°	PART NUMBER: MLSL035
DO NOT SCALE DRAWING		DESCRIPTION: Male Luer 500 Series Barb, 3/16" (4.75 mm) ID Tubing (May be used with separate stationary lock ring; FSLLR)	
DRAWN BY: SUE CORAM	SCALE: NTS	DRAWING NUMBER:	REV.
DATE: 08/22/97	© 1997 VALUE PLASTICS, INC.		SHEET:

FOR REFERENCE ONLY