

NOTE: FOR MORE DETAILS SEE YOUR V.P.CUSTOMER SERVICE REP.

REVISIONS			
REV.	DESCRIPTION	DATE	APPROVED
A	ECO-0029	08-11-00	
B	CO 015 Drafting Update	05-16-05	Rick C.

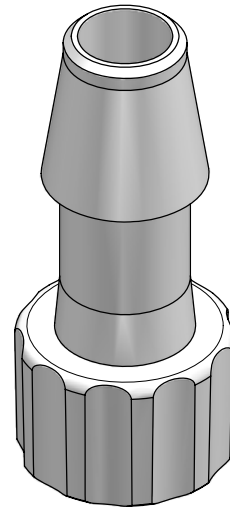
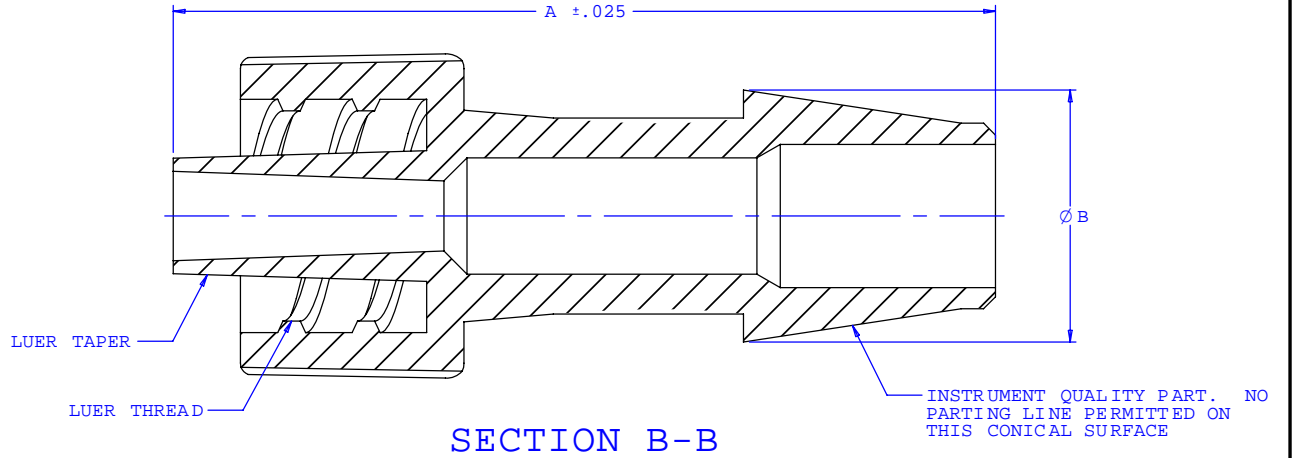
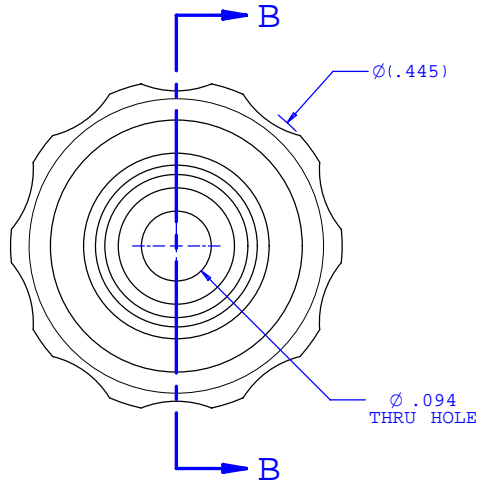

Dimension	Material Specific Tolerances							
	Acetal	Nylon	PP	ABS	PC	PVC	Polysulfone	J1A
A	1.103	1.103	1.103	1.103	1.103	1.103	1.103	1.088
B	.338	.338	.334	.338	.338	.338	.338	.331
C								
D								
E								
F								

UNLESS OTHERWISE SPECIFIED DIMENSIONS ARE IN INCHES TOLERANCES ARE:		<b>VALUE PLASTICS, INC.</b>	
FRACTIONS ±	DECIMALS .XX ±.01 .XXX ±.005 .XXXX ±.001	ANGULAR ±1°	PART NUMBER: <b>MTLL360</b>
DO NOT SCALE DRAWING		DESCRIPTION: Male Luer Integral Lock Ring to 300 Series Barb, 1/4" (6.25 mm) ID Tubing	
DRAWN BY: <b>Frank Lombardi 04-27-05</b>	DATE:	SIZE: B	SCALE: NTS
Engineer/Manager: <b>Rick Cairns</b>		DRAWING NUMBER: <b>1006416</b>	REV. B
© 2005 VALUE PLASTICS, INC.		SHEET: 1 OF 1	

**FOR REFERENCE ONLY**