

NOTE: FOR MORE DETAILS SEE YOUR V.P.CUSTOMER SERVICE REP.

| REVISIONS |                        |          |          |
|-----------|------------------------|----------|----------|
| REV.      | DESCRIPTION            | DATE     | APPROVED |
| A         | INITIAL RELEASE        | 09-07-02 |          |
| B         | CO 013 Drafting Update | 04-25-05 | Rick C.  |

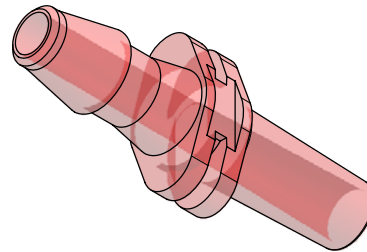
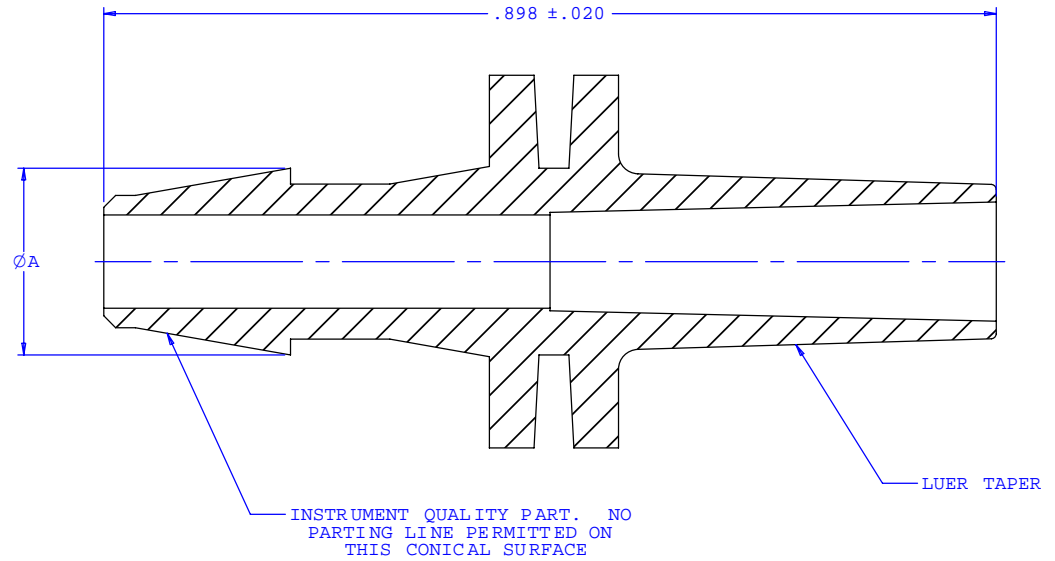
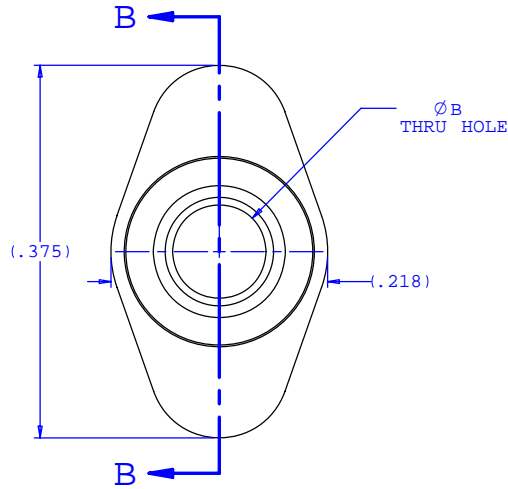

SECTION B-B

| Dimension | Material Specific Tolerances |       |      |      |      |      |             |      |
|-----------|------------------------------|-------|------|------|------|------|-------------|------|
|           | Acetal                       | Nylon | PP   | ABS  | PC   | PVC  | Polysulfone | J1A  |
| A         | .188                         | .188  | .188 | .188 | .188 | .188 | .188        | .182 |
| B         | .094                         | .094  | .094 | .094 | .094 | .094 | .094        | .089 |
| C         |                              |       |      |      |      |      |             |      |
| D         |                              |       |      |      |      |      |             |      |
| E         |                              |       |      |      |      |      |             |      |
| F         |                              |       |      |      |      |      |             |      |

|   |   |  |                                |
|---|---|--|--------------------------------|
| UNLESS OTHERWISE SPECIFIED<br>DIMENSIONS ARE IN INCHES<br>TOLERANCES ARE: |   | <b>VALUE PLASTICS, INC.</b>  |                                |
| FRACTIONS<br>±  | DECIMALS<br>.XX ±.01<br>.XXX ±.005<br>.XXXX ±.001 | ANGULAR<br>±1°   | PART<br>NUMBER: <b>MTLS230</b> |
| DO NOT SCALE DRAWING  |   | DESCRIPTION: Male Luer Slip to 200<br>Series Barb, 1/8" (3 mm) ID Tubing |                                |
| DRAWN BY:<br><b>Frank Lombardi 4-18-05</b>                                | DATE:   | SIZE: <b>B</b>   | SCALE: <b>NTS</b>              |
| Engineer/Manager:<br><b>Rick Cairns</b>                                   |   | DRAWING NUMBER:<br><b>1005578</b>  | REV. <b>B</b>                  |
|   |   | © 2004 VALUE PLASTICS, INC.  | SHEET: <b>1 OF 1</b>           |

**FOR REFERENCE ONLY**